

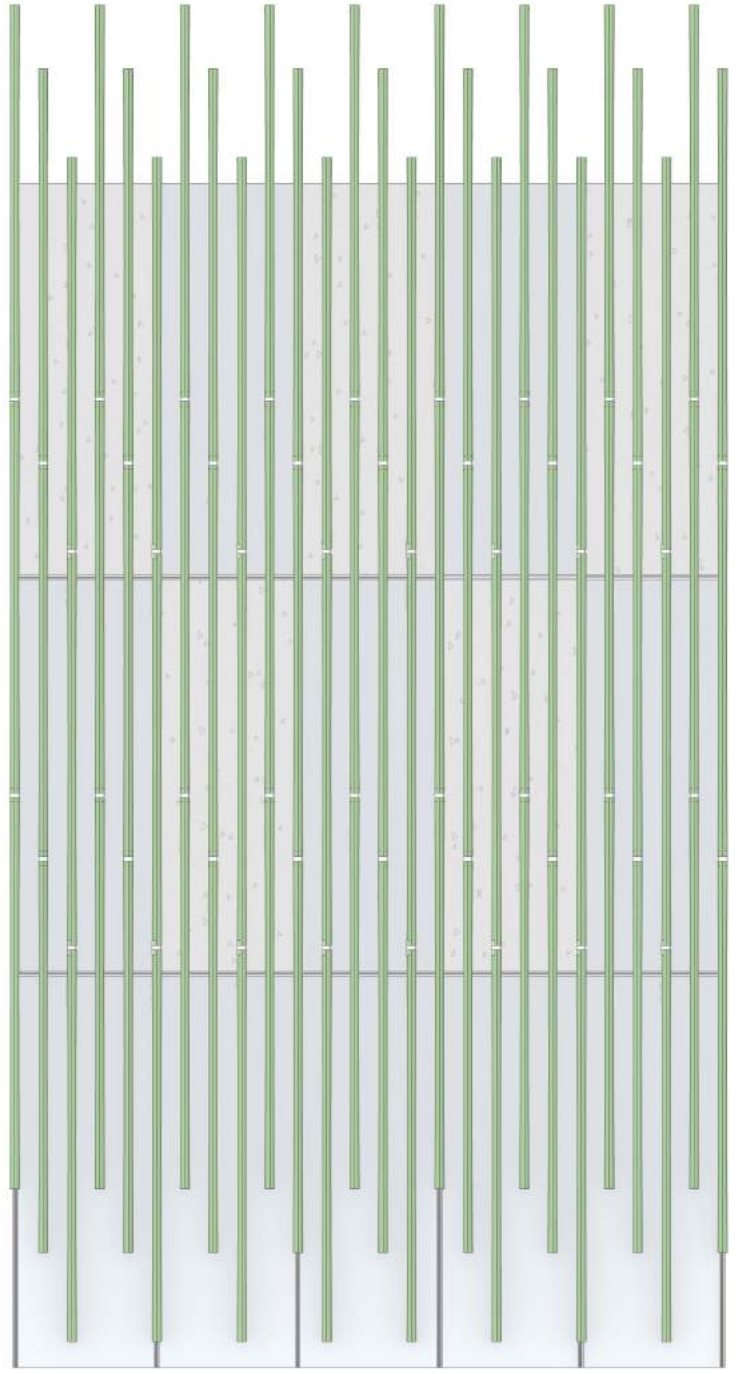

Ross Bleckner, Cage, 1987

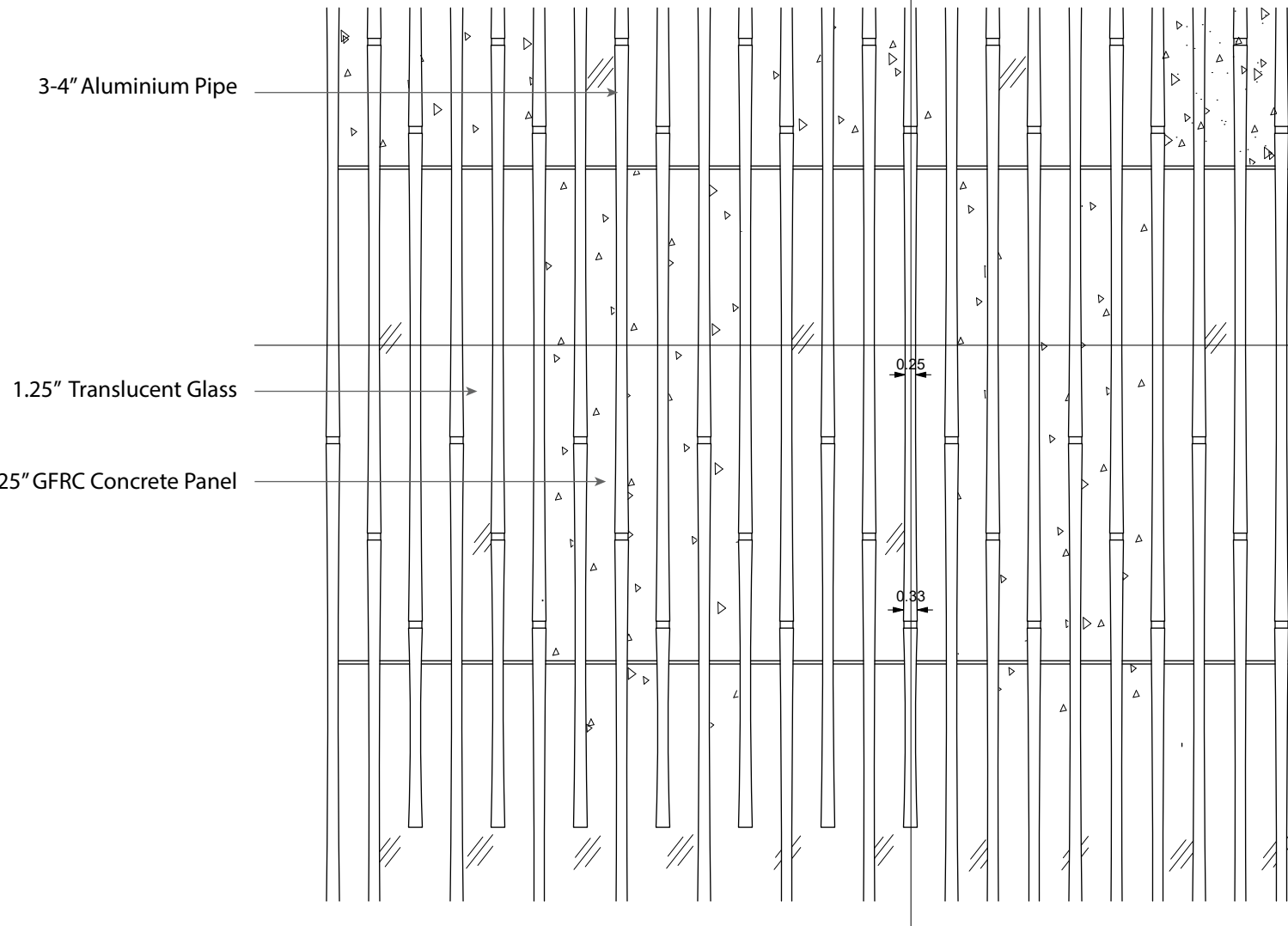



Typical Elevation
1/4" = 1' - 0"

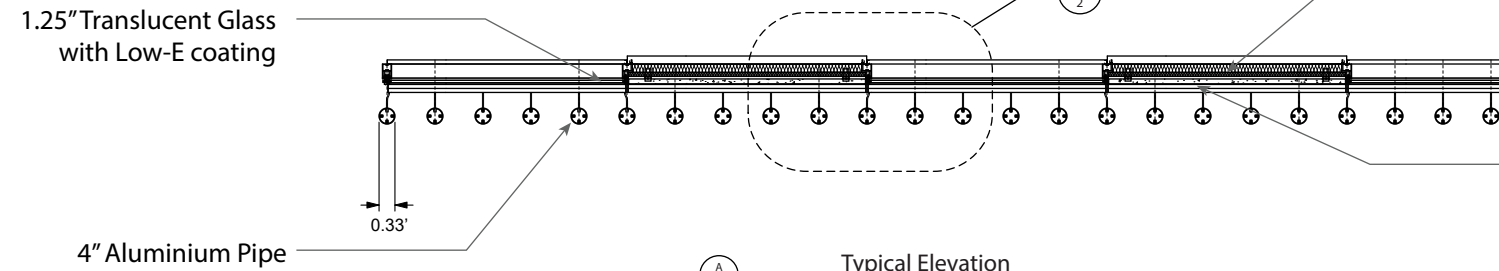
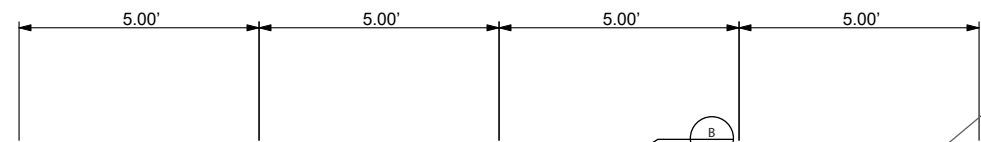

Typical Elevation
1/4" = 1' - 0"

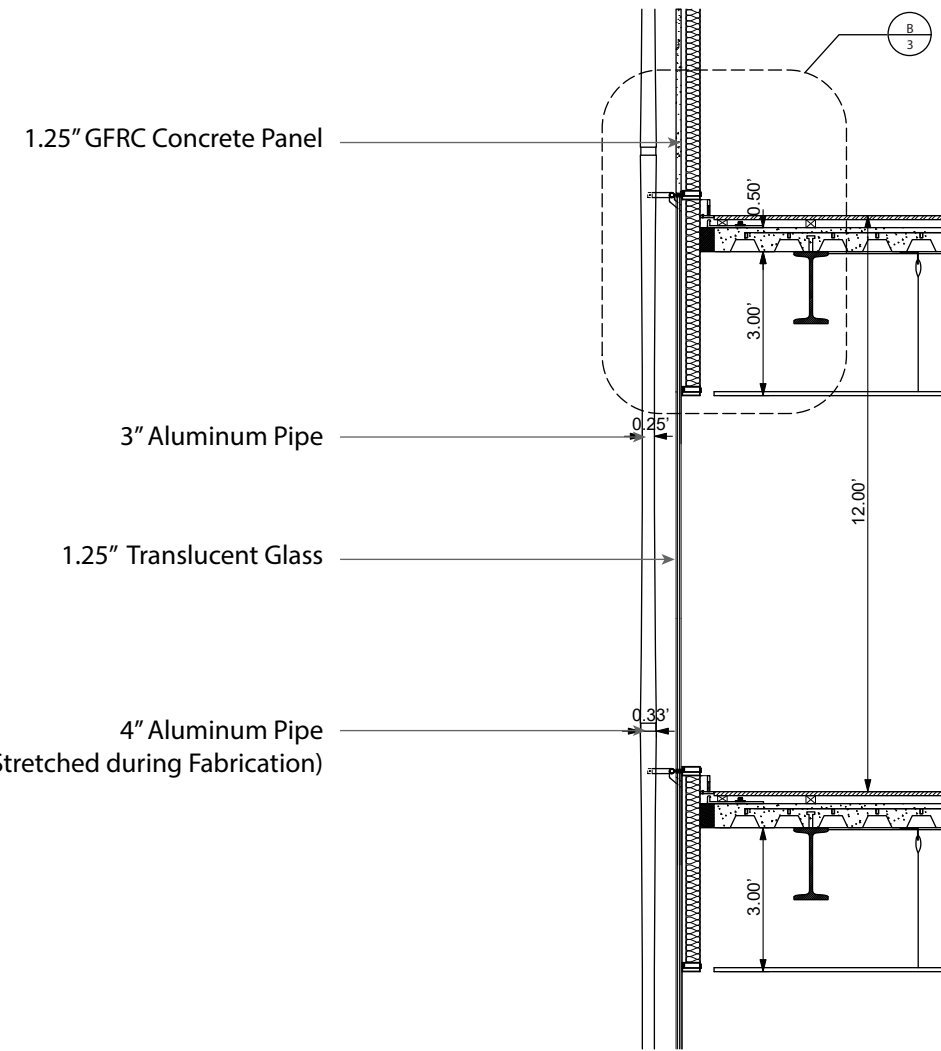
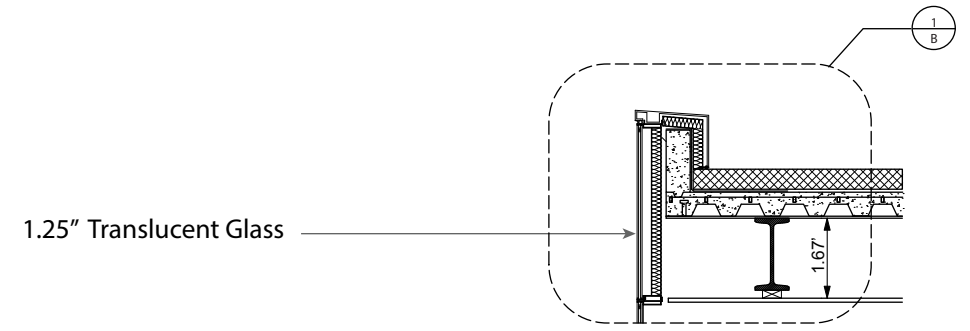

Typical Section
1/4" = 1' - 0"

ADV Curtain Wall
Roadmap
Qingying Wang (qw2246)

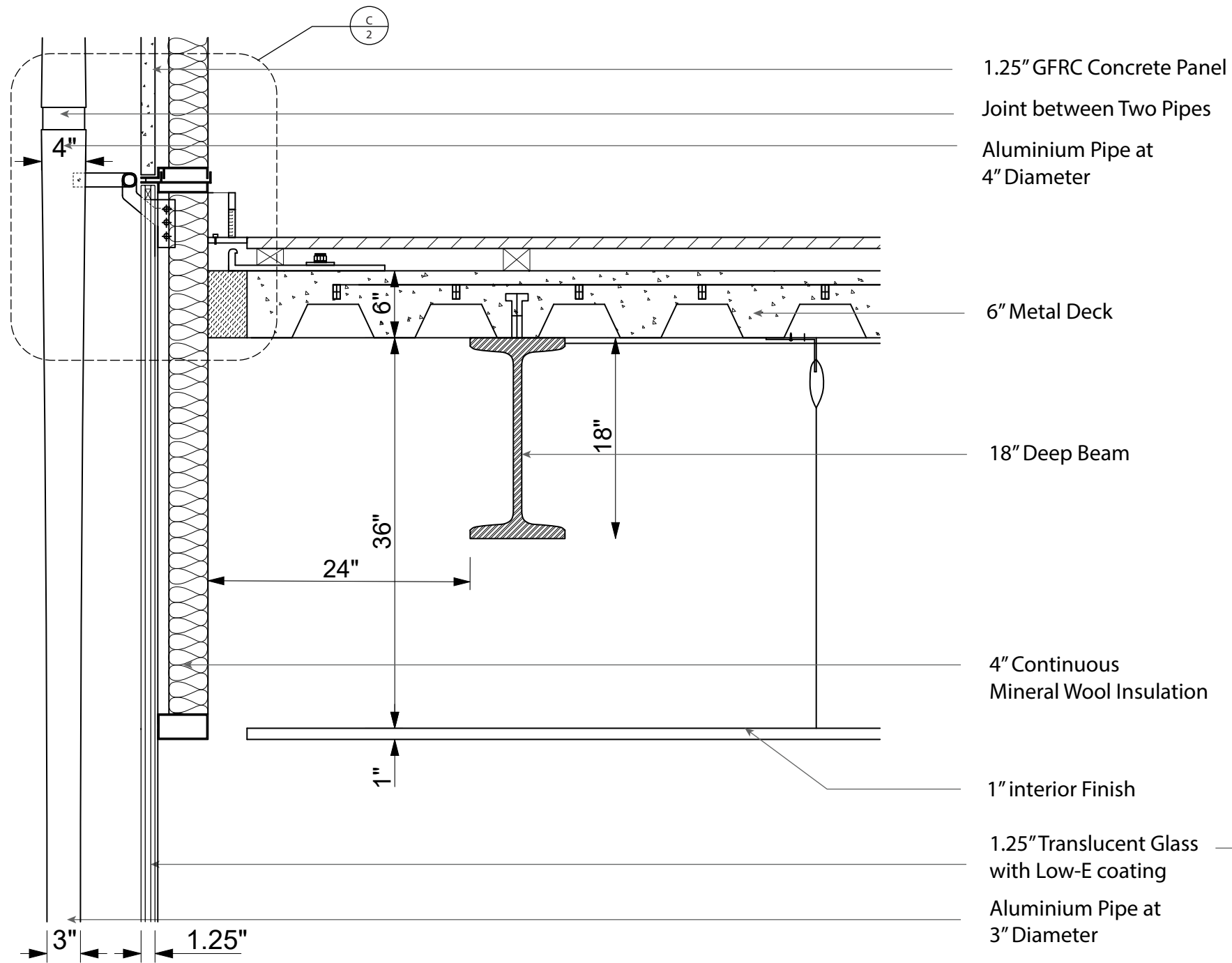

WT1 Typical Section Detail
 1/2" = 1'-0"

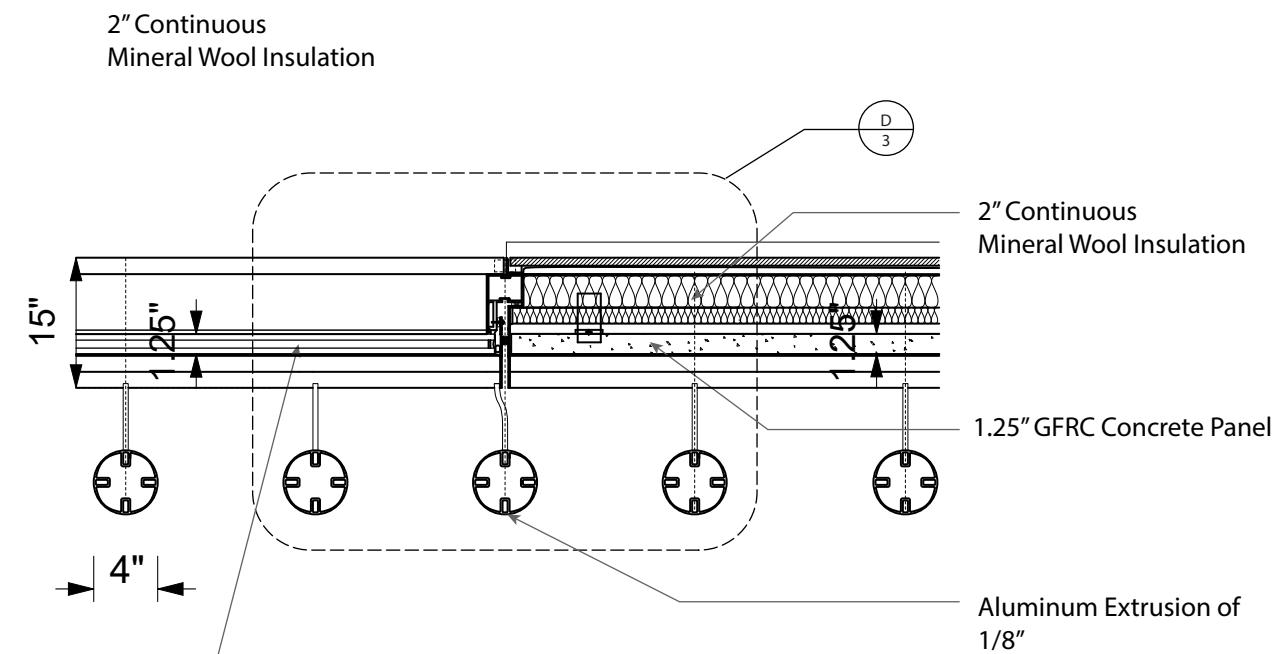

WT1 Typical Plan Detail
 1/2" = 1'-0"

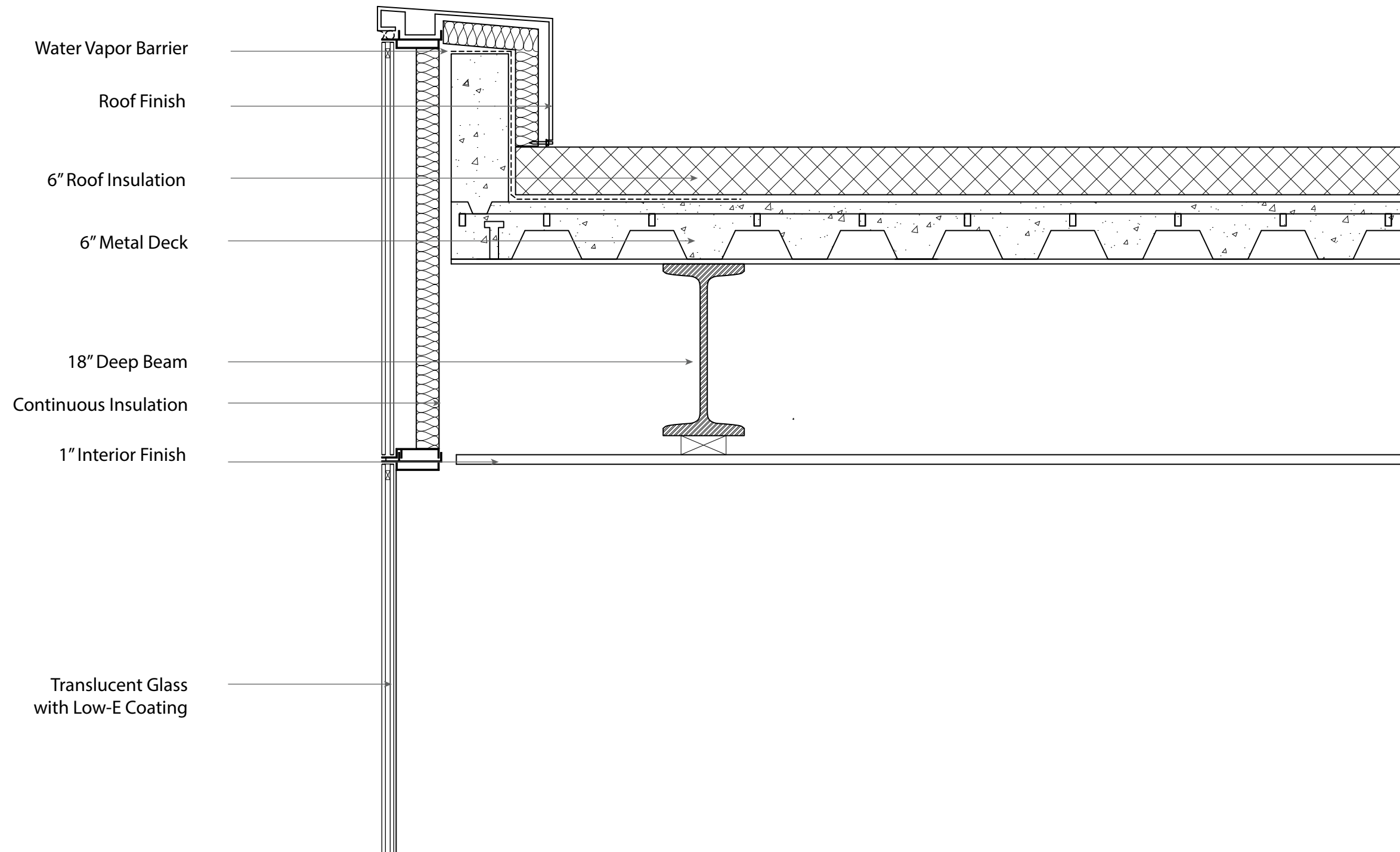

WT1 Typical Section Detail
 1/2" = 1'-0"

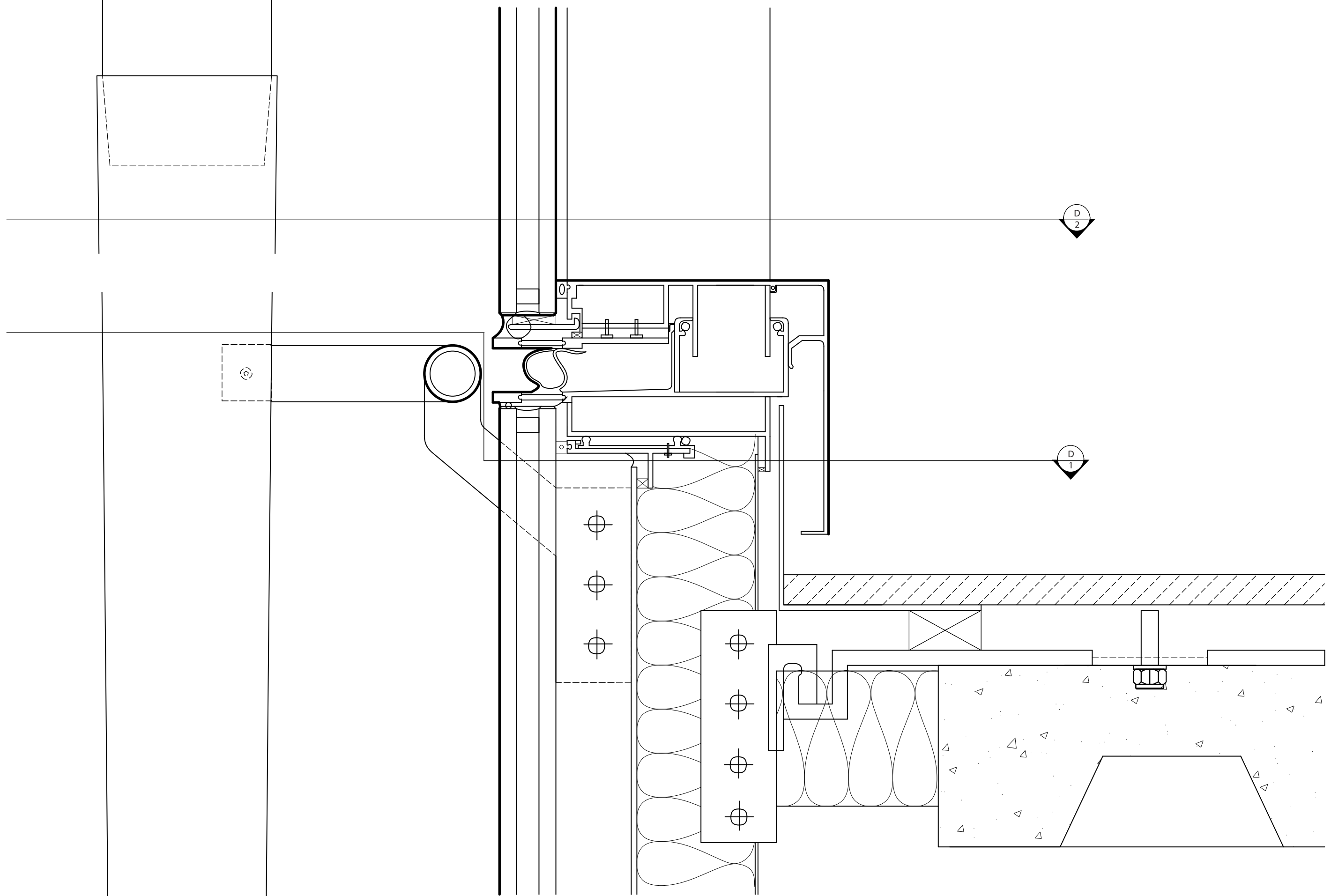

C1 Mullion Typical Section Detail
6" = 1' - 0"

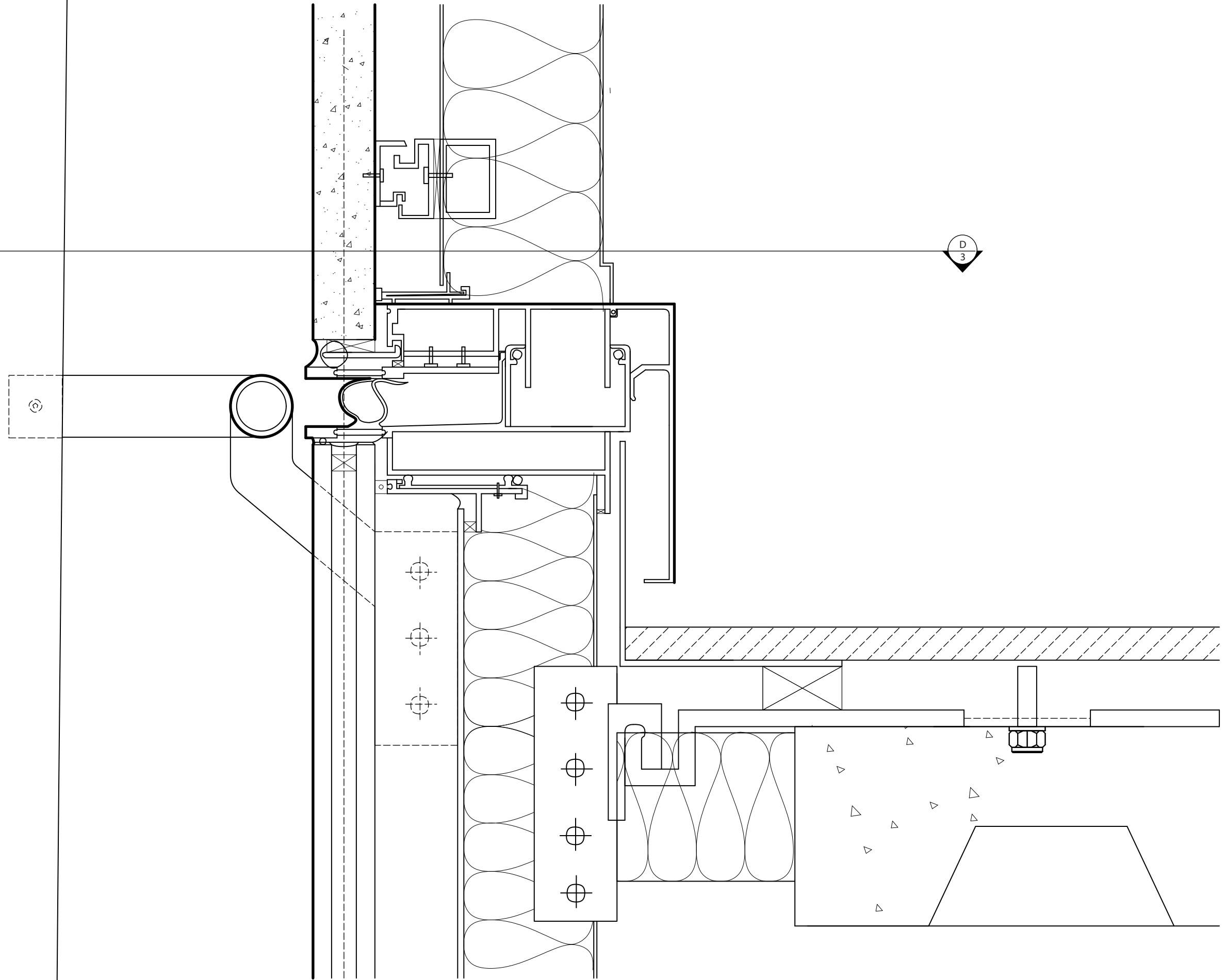

C2 Mullion Typical Section Detail
6" = 1'-0"

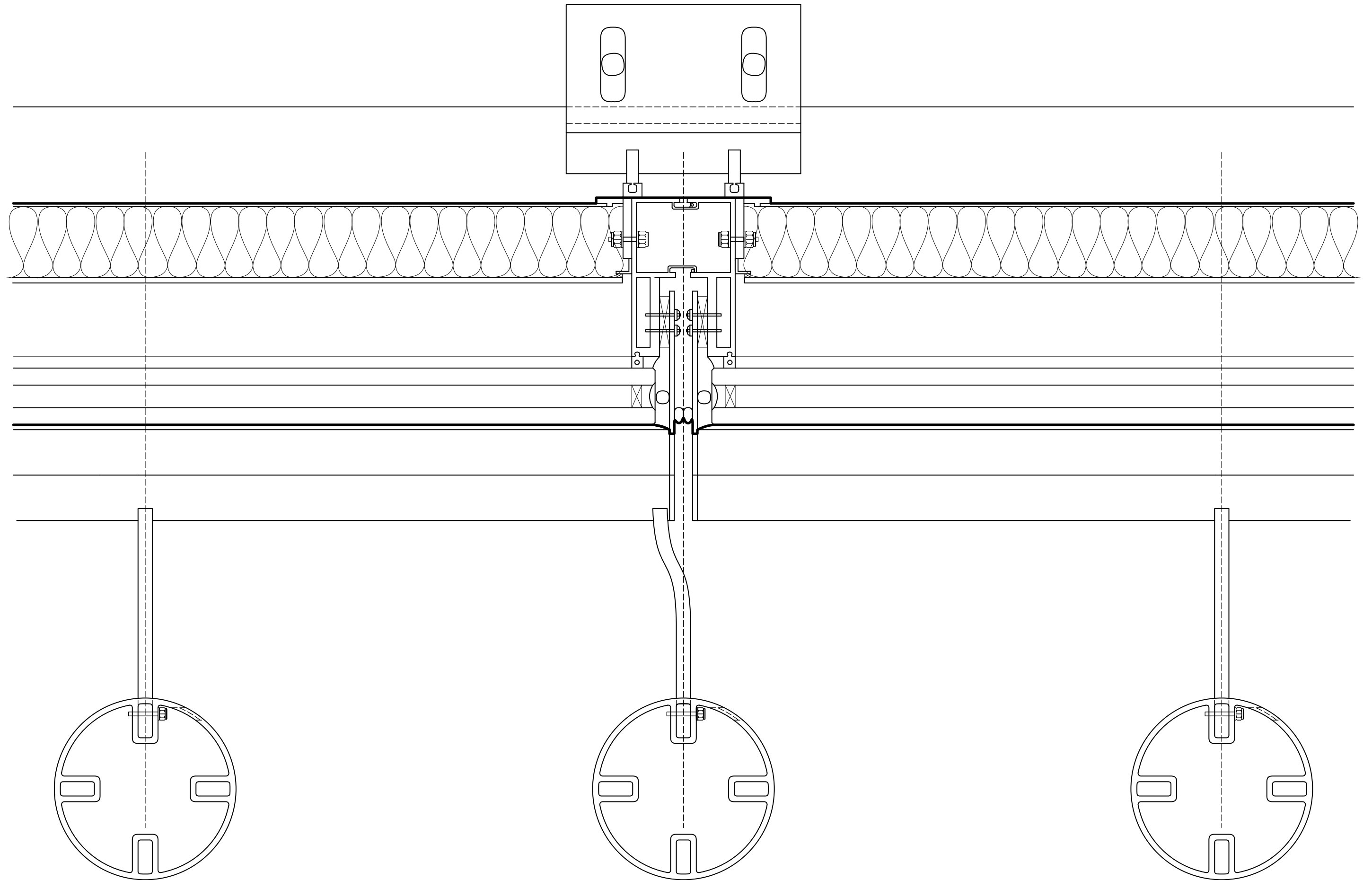

D1 Mullion Typical Plan Detail
6" = 1'-0"

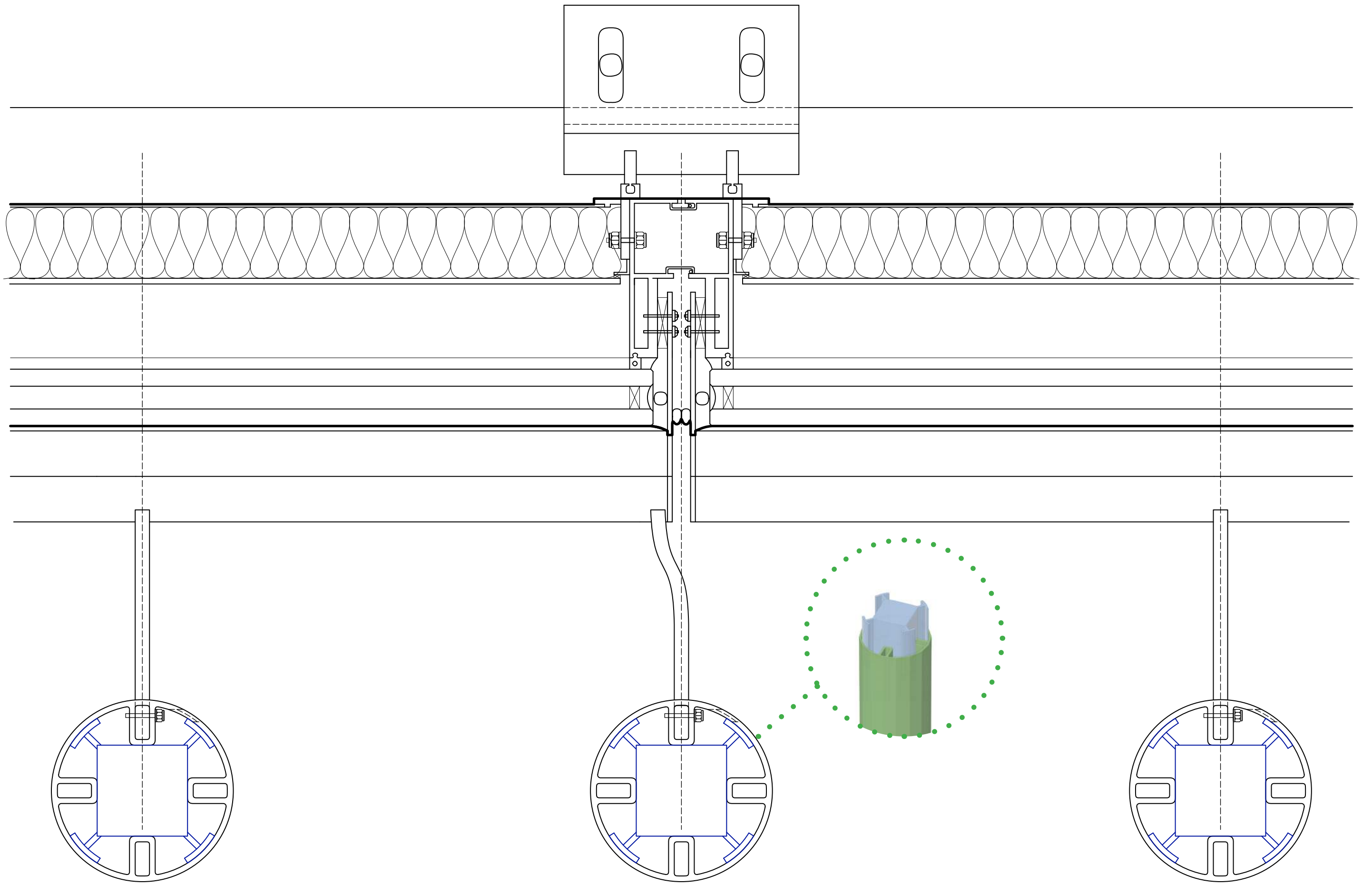

D1 Mullion Typical Plan Detail
6" = 1' - 0"

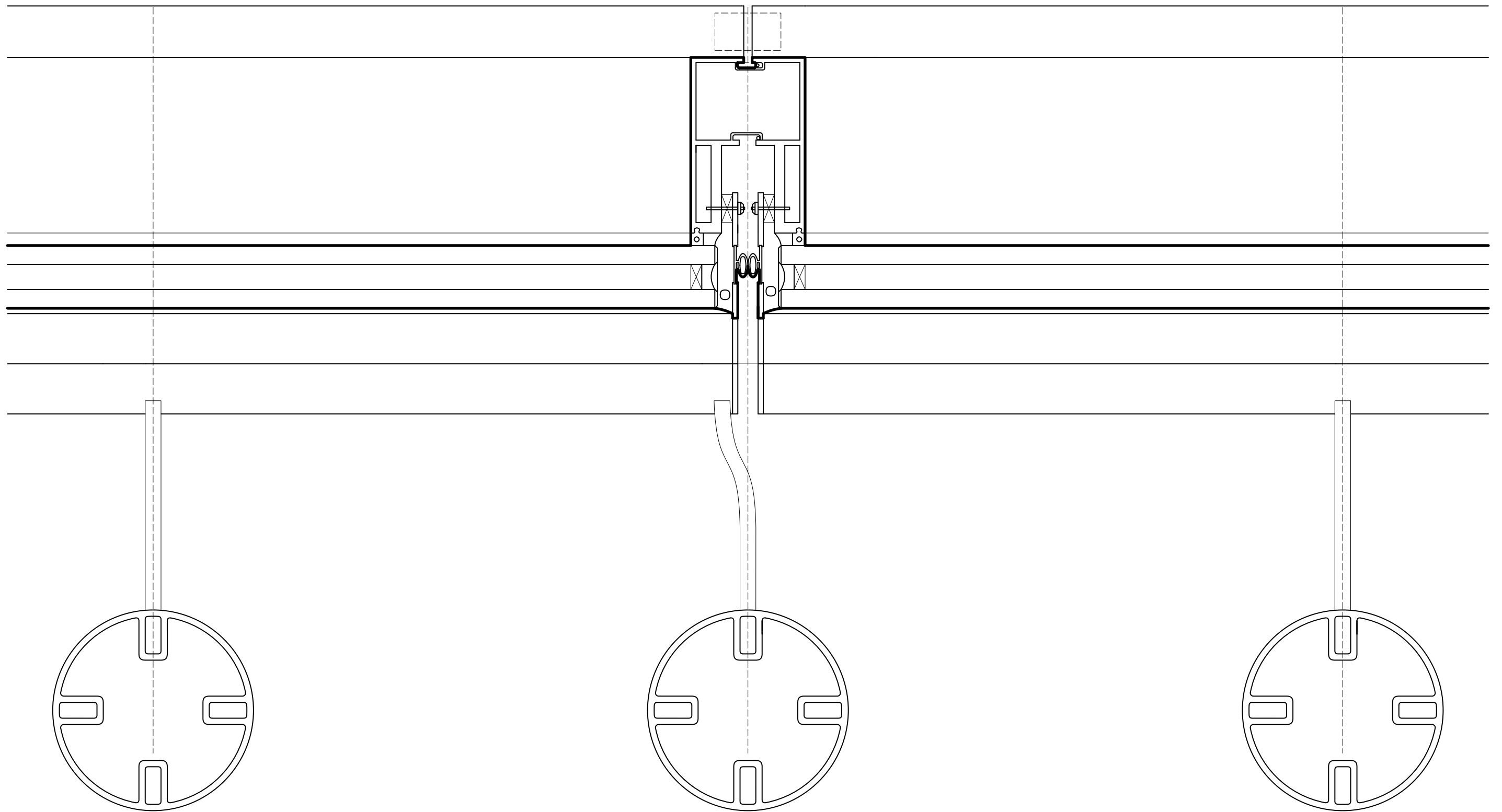

D2

Moullion Typical Plan Detail
6" = 1'-0"

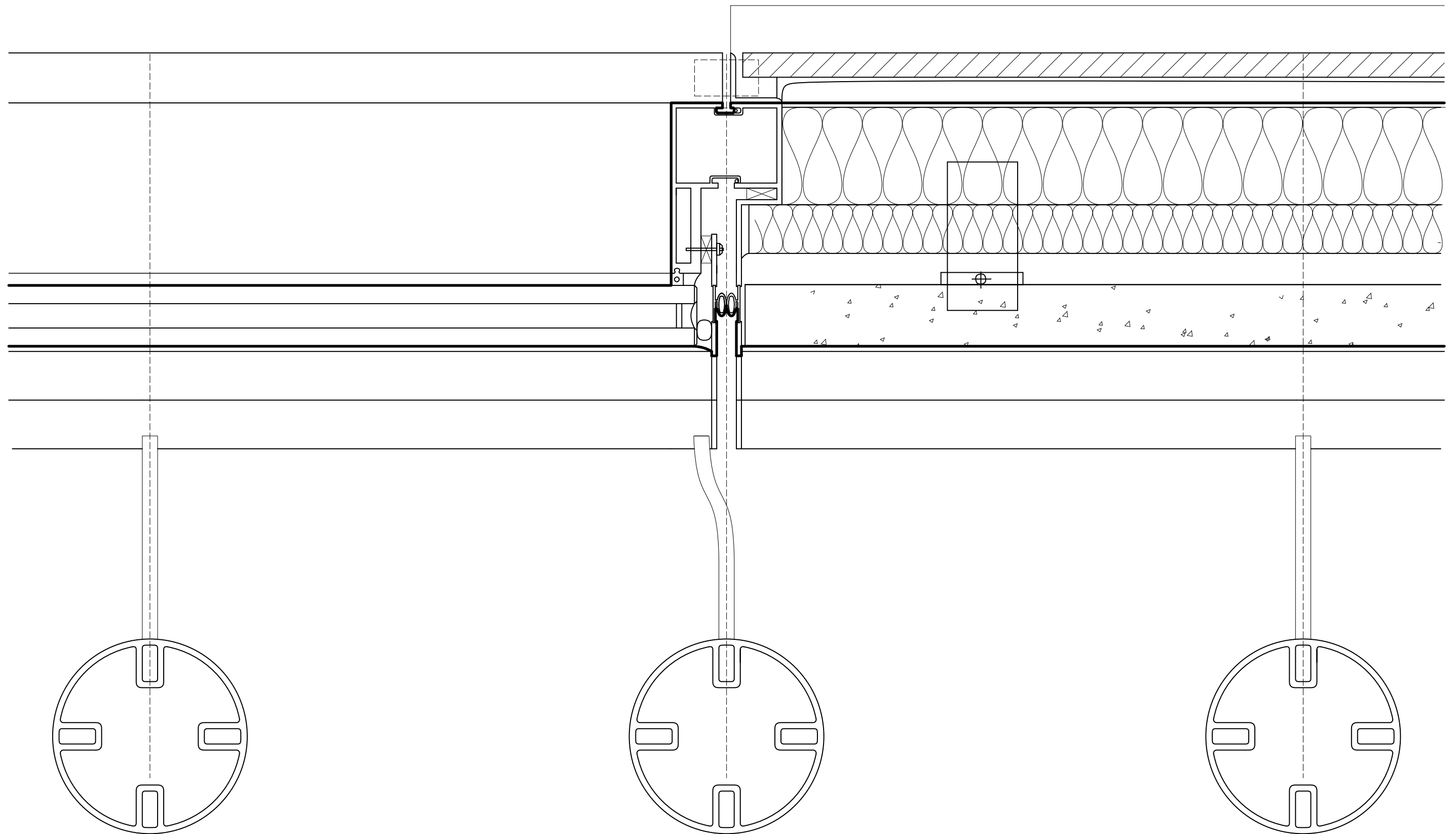

D3 Mullion Typical Plan Detail
6" = 1' - 0"