

Introspective utopias



MSAAD Columbia GSAPP

Daniela Beraún

2022

In times of crisis, we find shelter in our utopias. They infuse everyday reality with other, possible worlds and allow us to regain the agency that is otherwise lost. Introspective Utopias is a soft collection of works that share the pulsation to gain a very personal sense of self, place and purpose. This body of work was developed looking inwards, but also having endless conversations and obsessively searching for a method to place practice in a larger context of architectural ideas. Through these utopias, I learned to unravel, to pull the thread on ideas, and to use intention as a starting point for a critical practice of architecture.

The studio projects

are thought from the inside out, symbolically as a personal process, but also literally as a very tangible design approach.

The essays

are the result of generous conversations with others, where architecture becomes the more, and least, architectural.

The diagrams

are a methodological search to place practice in context, to understand where it is situated in a greater network of ideas.

Table of contents

<p>08-33 <i>The nurse station</i></p> <p>Studio Small Footprints Hilary Sample</p>	<p>34-35 <i>Dissecting conformity in architectural practice</i></p> <p>AAD Podcast: Raadio</p>	
<p>36-51 <i>Castle in the sky</i></p> <p>Studio Unadapted Wonne Ickx</p>	<p>52-55 <i>Debunking participatory processes in Latin America</i></p> <p>Latin GSAPP magazine PATIO</p>	<p>56-61 <i>Ricardo Bofill: situated practice</i></p> <p>Seminar Unorthodox Arch Practices Juan Herreros</p>
<p>62-81 <i>Post-school childcare infrastructures</i></p> <p>Studio Infrastructures for the countercollapse. Ignacio G. Galán</p>	<p>82-87 <i>A book to change the world</i></p> <p>Seminar History of Architectural Theory Mark Wigley</p>	
	<p>88-97 <i>Aldo Rossi goes to trial</i></p> <p>Seminar Architecture: The Contemporary Bernard Tschumi</p>	<p>98-99 <i>The Gen-Z manifesto</i></p> <p>Seminar Architecture: The Contemporary Bernard Tschumi</p>

The nurse station



The nurse station is a project for the Traveling Nurses of NYC. Inspired by the Henry St. Settlement — the house where the organization started — this headquarters is a place where the nurses focus on their own physical and mental well-being. The project aims to be deeply domestic, through shared spaces and sound, and at the same time a recognizable, small footprint symbol of the organization at the city scale.



This project expands the idea of a clinic to consider spaces that focus on the individual body of a person. This is particularly critical when thinking about traveling nurses as body-powered clinics. The nurse station serve as a base of operations, but also as a political center in the sense that the nurses get to meet each other and have conversations. Like fire stations, one can imagine one nurse station in every neighborhood. This particular one is developed as an adaptive reuse project on the corner of 47th Street and 9th Ave, in Clinton.

The nurse station



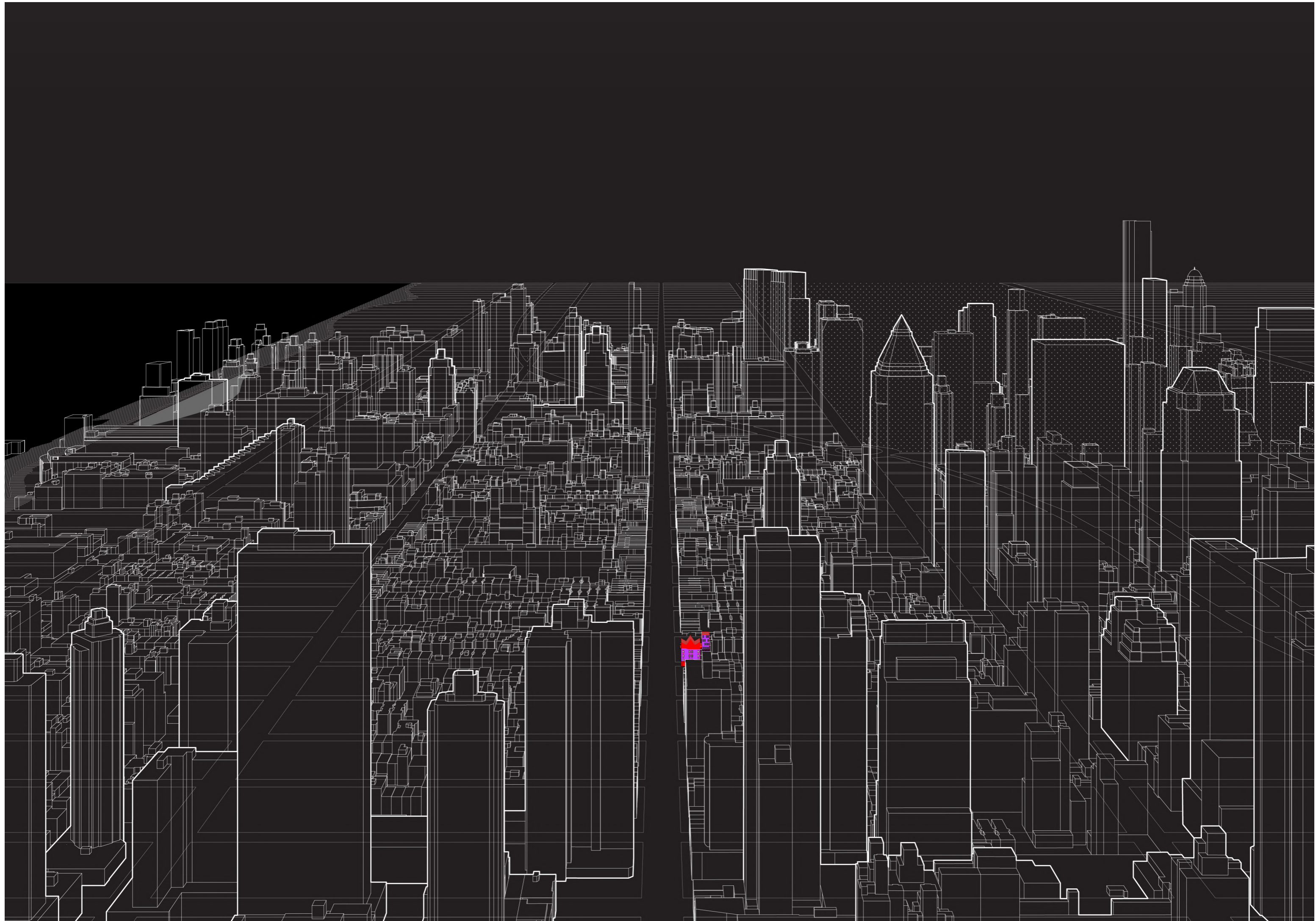

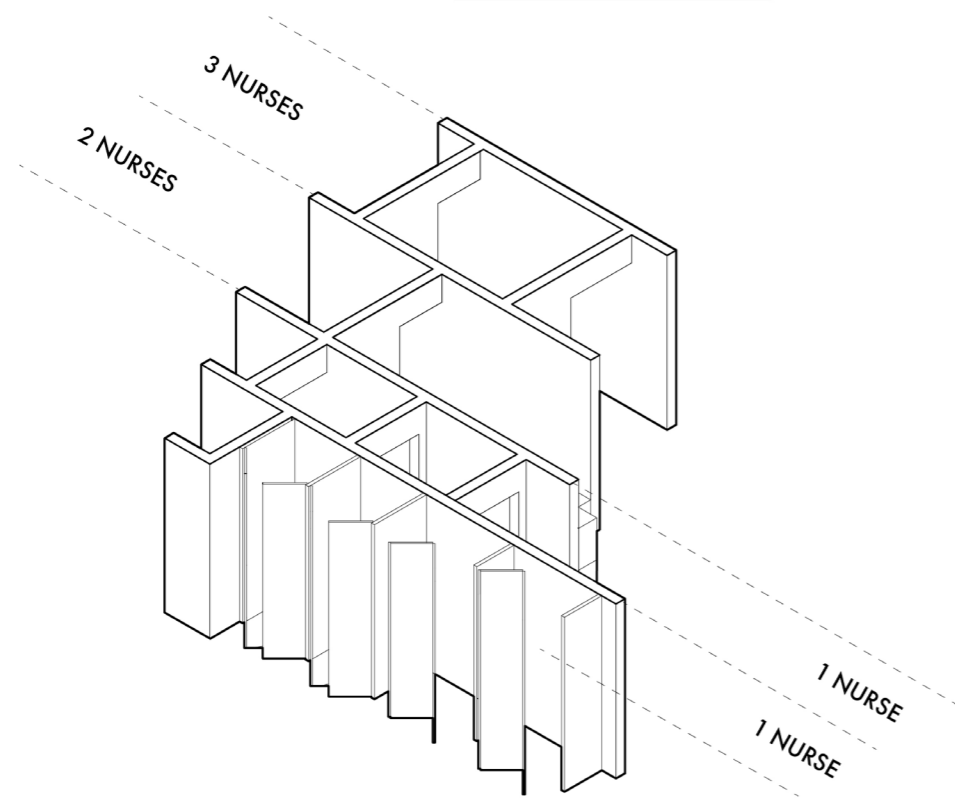
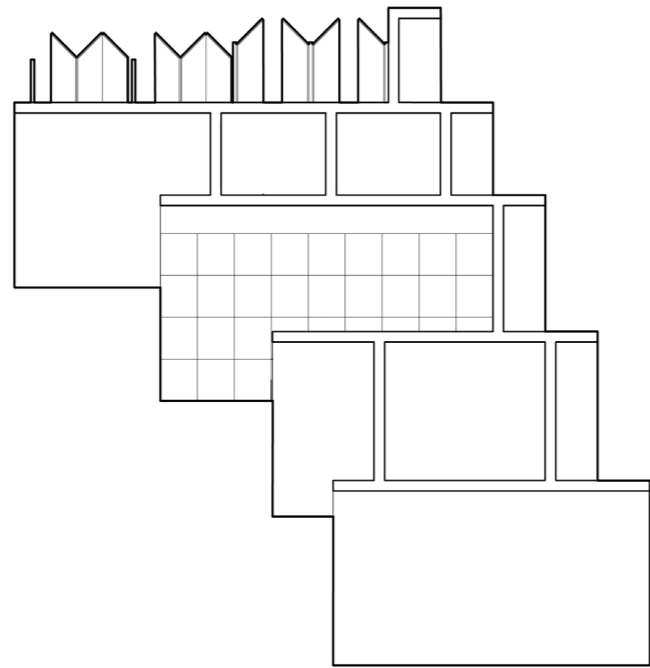

Spatial explorations were triggered by thinking about the space one single body occupies as a "unit of care". Also, by the idea that the domestic is configured by a collection of artifacts rather than an abstract space, and by how circulation defines a more public trace, even if its within an overall very private territory.

Domestic versus public

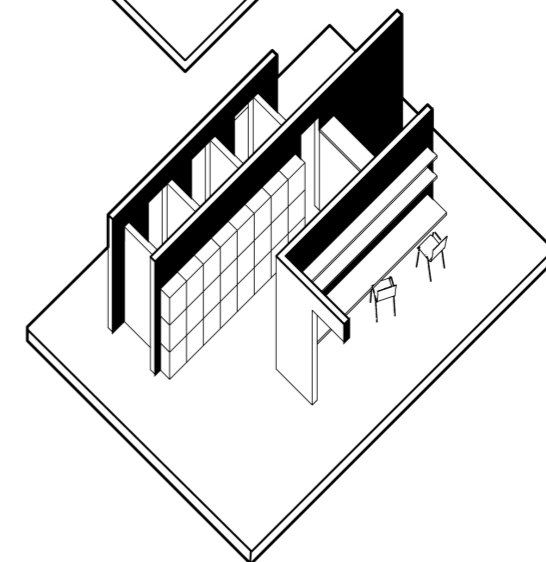
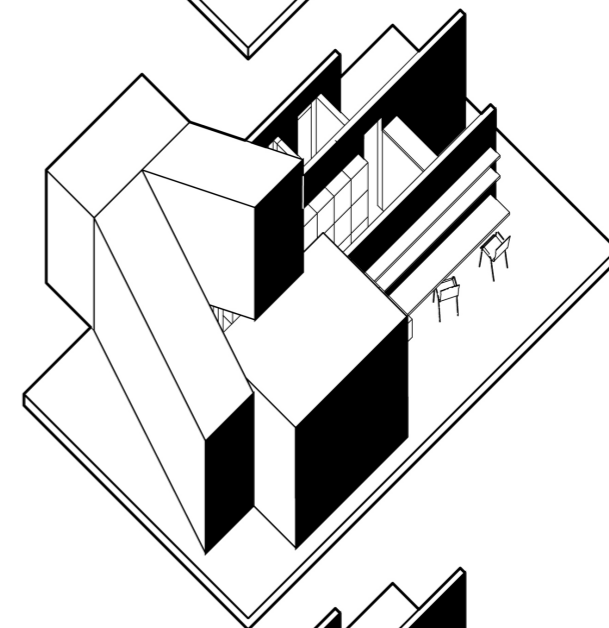
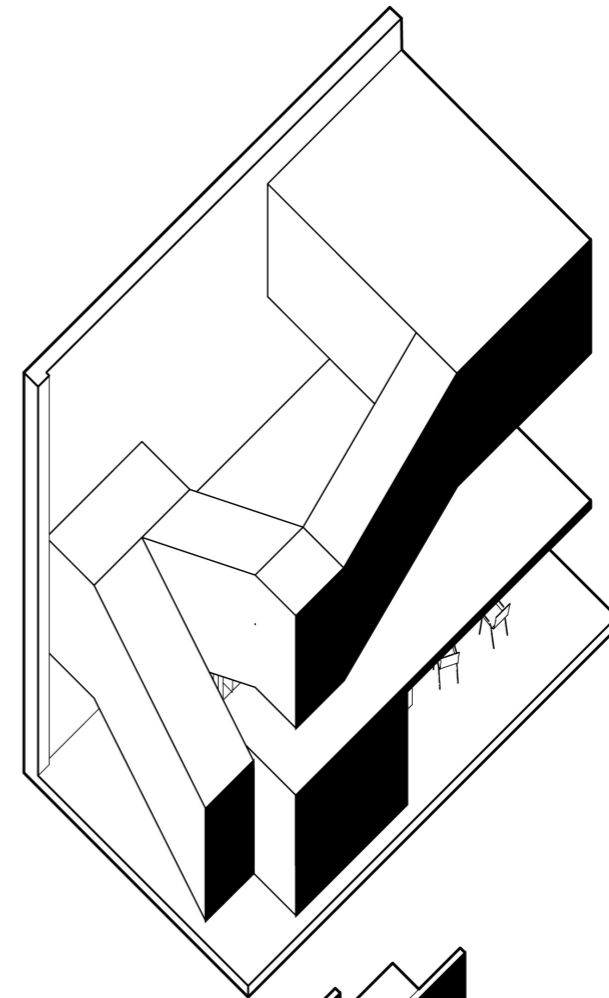



The lot has originally 3 buildings. One is repurposed as housing for nurses by adding an egress stair and elevator on the back side of the building. This also structurally allows for more floors to be added. The second one hosts all services like bathrooms and showers so it is adapted to have ventilation ducts and space for installations. And the last one - the corner building - has the main circulation and the spaces for therapy and activities.

Domesticity in this project is the shared sound. From the entrance, through the common kitchen on the upper floor, all the spaces have openings towards the winter garden which is an open but interior space that allows sound to travel between the different spaces.





The fifth floor, which is originally the roof of the existing buildings, is now a common kitchen / working space connected to a living room in the housing building. There is also a mezzanine space at the end of the green spiral staircase that can be used as a small music room.

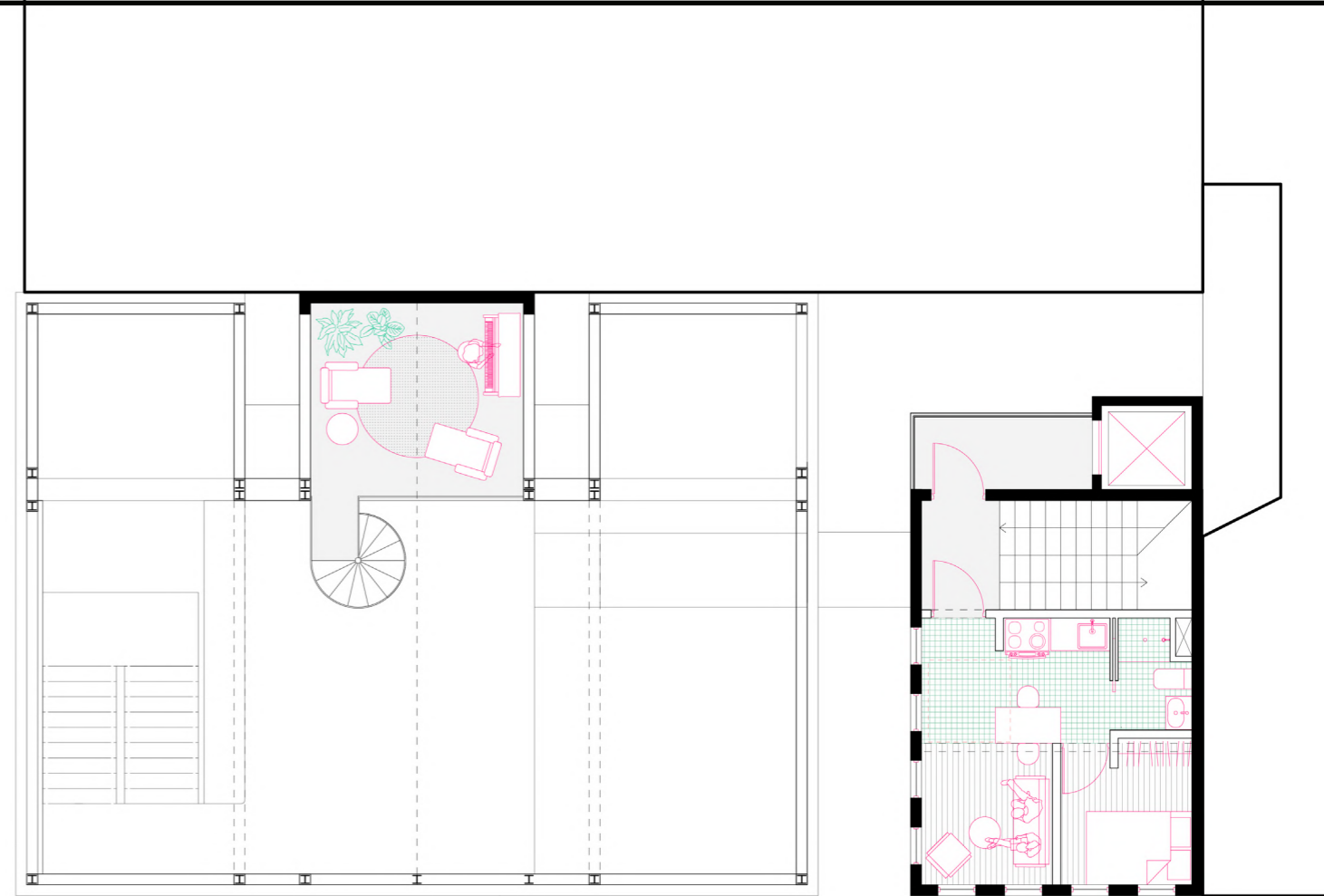

Mezzanine level

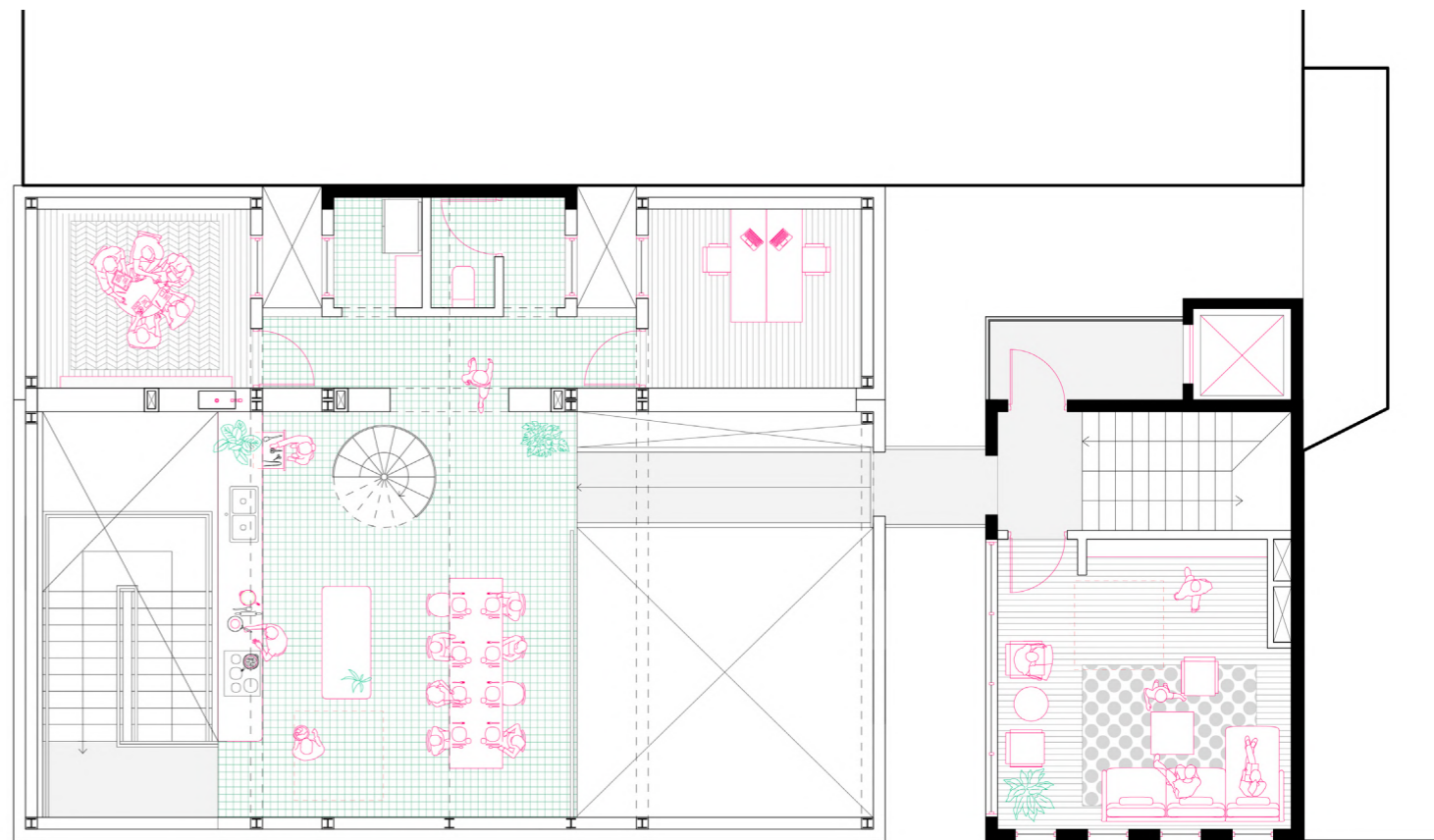

Fifth floor





The entrance to both the station and the housing building is through a shared vestibule that is below the winter garden. The first two floors are destined to fulfill basic needs of the traveling nurses such as changing clothes, showering, and doing laundry. There is also a community space and a larger event room with storage.

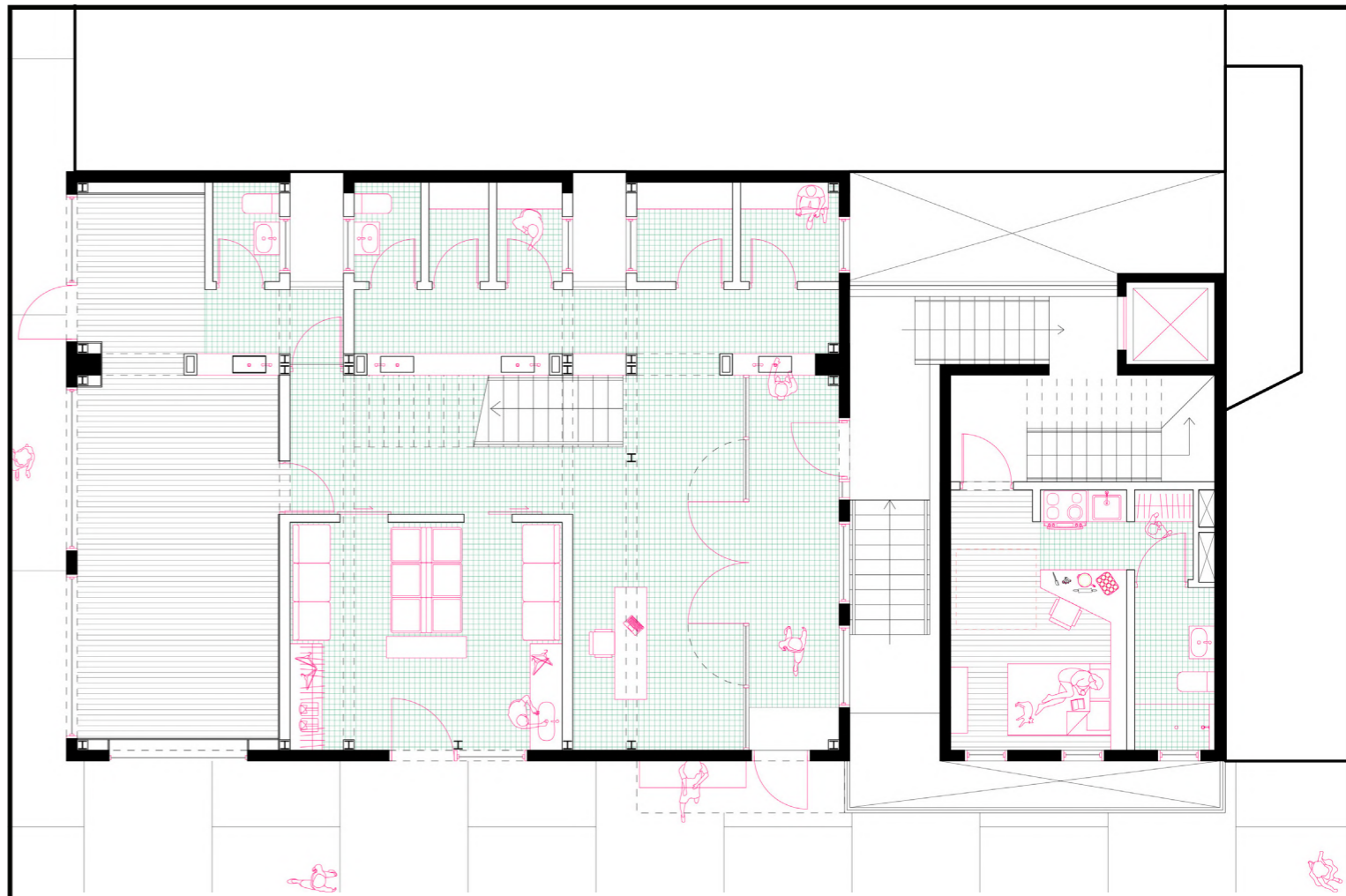

Ground floor

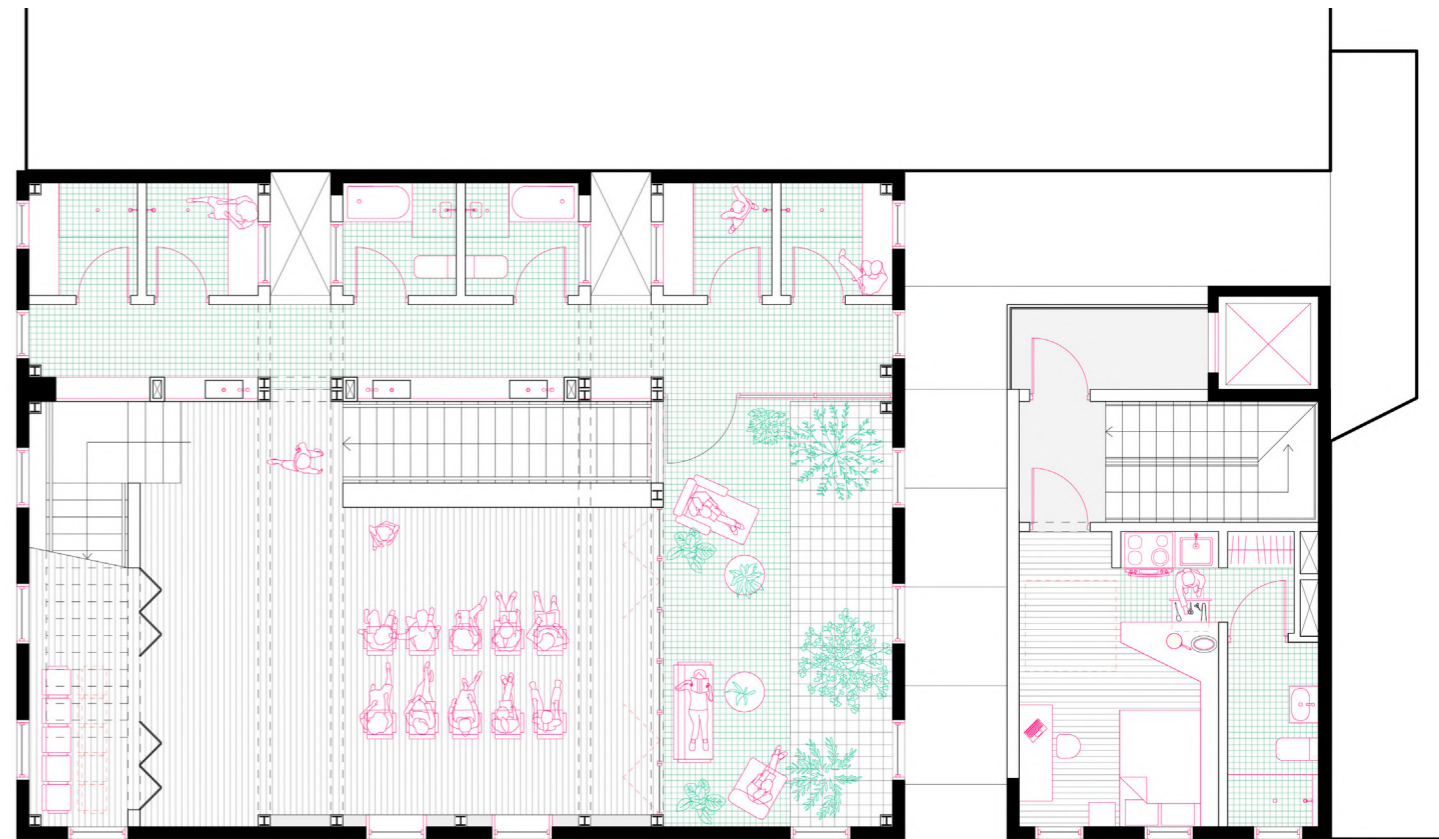

Second floor

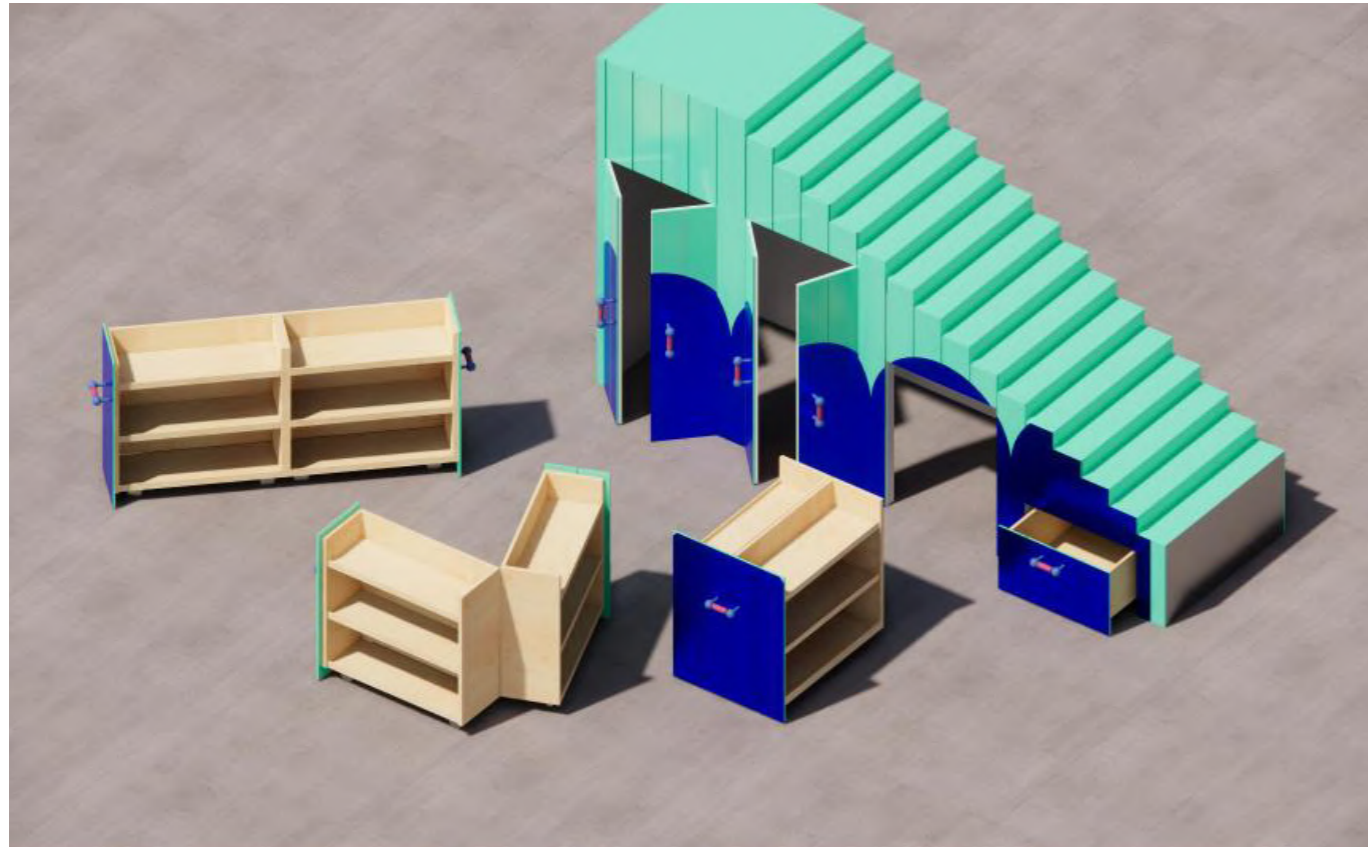

This furniture piece was designed as part of the architecture of the event room. It renders the space under the staircase usable mainly for furniture storage but also with movable shelves that can be taken out and adapt to the flexible use of the space.

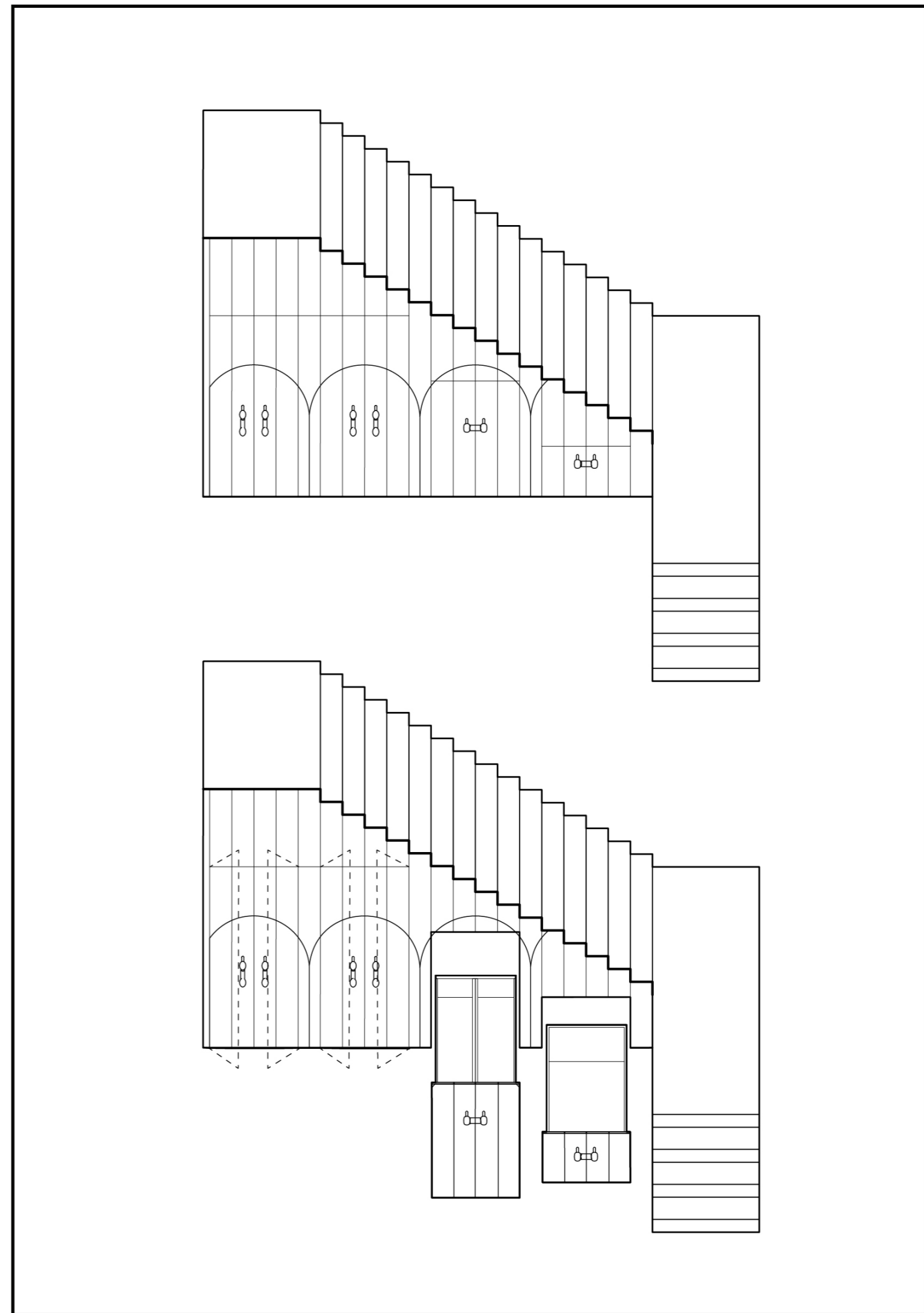

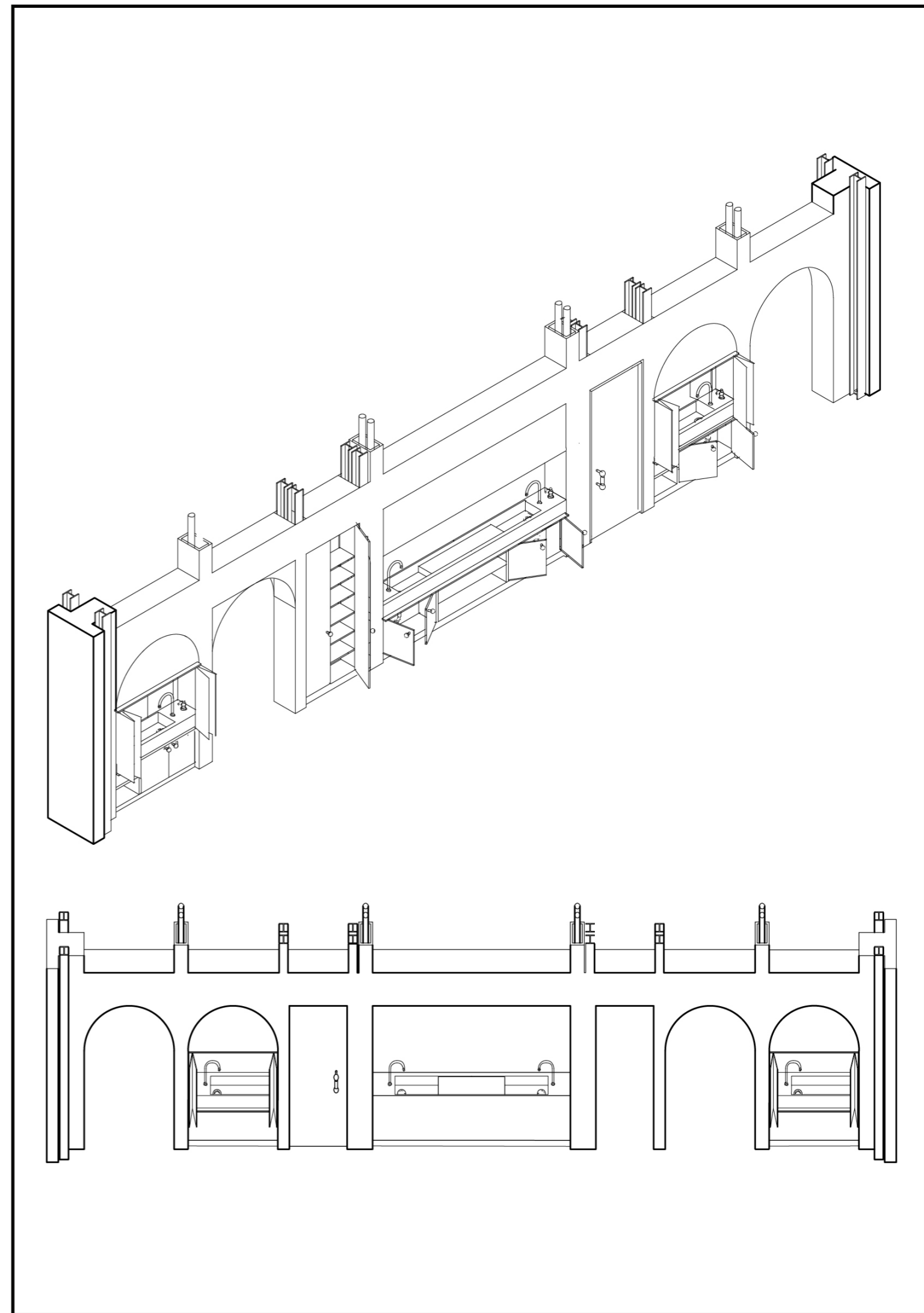

A “wet closet” was designed for every floor, in between two of the existing buildings. It resolves the problem of the need for ducts for installations, and it adds sinks and additional storage to the spaces.





In the spirit of the traveling nurses, the constant movement – the actual and the symbolic – configure the facade of the building.

Dissecting conformity in architectural practice

AAD Podcast: Raadio
Editorial Board 2022:

Aahana Banker,
Daniela Beraún,
Rocio Crosetto Brizzio,
León Duval,
Dhruva Lakshminarayanan,
Malavika Madhuraj,
Hein Song

Season 2

rAADio is a research and sound project by a group of students in the Advanced Architectural Design program. We centered the second season around issues of practice. For us, practice includes designing, writing, teaching, drawing, fabricating, performing, but also, it may include “just” thinking and learning. This is, actually, at the center of this season: we want to open the conversation about the expectations of architectural practice in academia and the workplace — like having to be always productive — to show that a non conforming practice has many faces, and can be enacted in many ways. It may be as simple as making the choice to go to sleep. This second season is structured in 3 chapters, with two episodes each: sleepless in practice, resistance in practice, and misfits in practice. Our aim is to begin to expose how we play a part on the networks that exploit our bodies, our labor, and our resources in order to fulfill the expectations of an increasingly demanding world. In the role of general editor of the podcast, my main concern was for the scripts to have interesting content, written in the right tone and that could be delivered in the tight format we set up to do (10-12 min episodes).

Sleepless in practice:

Do we need to be sleep deprived to produce good architecture?

Up until not many decades ago, the 24/7 universe was more of an utopian idea of a world without shadows, a capitalist fantasy of never-stopping progress. Now, this might be closer to what people experience in their daily lives, with physical, digital and chemical infrastructures that are designed to sustain the prolonged operability of the bodies. Sleeping, on the other hand, is inherently unproductive, and, for that same reason, one of the last bastions of resistance against the consumer society. Sleeping can not be exploited by the logics of the market. Rather, it is its deep uselessness what makes it a space that still belong to us. The first two episodes of rAADio collect different examples of how humans have persistently tried to achieve a state of sleeplessness to be able to enhance creative production, soldier performance, or simply keep up with contemporary job demands. We also highlight how this search is supported by architecture infrastructures, devices and drugs. In these episodes we argue to fight back against the continuous reduction of sleeping time as a form of non conforming practice: to challenge the all-comprising capitalist logics and retain a space that is not governed by the 24/7 demands.

Resistance in practice:

Do we need to pick passion over profit to be a good architect?

Is it really work if we love what we do? A question that we face continually, either we realize it or not, from the moment we start architecture school. But, what are the consequences of not seeing ourselves as workers for our own wellbeing and for the larger community of architects? We felt compelled to talk about working conditions issues within the practice of architecture due to the many recent attempts to change the working culture of the profession. From unions, to strikes, to online scandals and social media pages that act as a political center base. We discuss examples where unions and other alternative systems have been crucial to achieve better work conditions, or that at least have opened the conversation at a larger scale. Under the question of passion versus profit we compiled recent cases in academia and the workplace that we see as ways of practicing architecture in a non conforming way, because they are resisting a status quo that go beyond the specific issues in our field. With these episodes we aim to salvage the current climate of heavy questioning. We want to use our voice to echo our peer’s, and also to make visible the precarious environments we are part of, specially as recently graduated students.

Missfits in practice:

Do we need to build at all to be an architect?

Traditional architecture has always been taught and practiced as a rigorous profession that leaves zero to no time to develop passions outside of it. Nevertheless, our discipline is breaking boundaries. We see architects doing exhibitions, investigating research, writing books, and even cooking. In the last two episodes of rAADio we explore and discuss the work of architects off the beaten path. We talk about the cracks in which architectural “notions” spill over other disciplines, for instance in recognizing the structure of a text in architectural terms and how both possess the potential to make us slow down, speed up or stop to contemplate. We also have a conversation about the potential of architectural images to reveal ideas, and not just being descriptive, to the point that many research and activist organizations are using architectural tool-sets to strengthen their arguments. Our aim with these episodes is to go outside the familiar, restrictive box of conventional architecture, and see that there exists a whole other world, with multitudes left to unpack, and hopefully empower our peers to go after their own passions, even if they are deemed “not architectural enough”.

Castle in the sky



This is an adaptive reuse project of the 13th Regiment Armory in Bed-Stuy, Brooklyn. Inspired by the SESC's in Brazil, the Armory is converted into a 21st century leisure and cultural center. The project connects to the site through the ground and the sky, creating moments of visual relation with the existing building but separating the intervention from it. By creating new perspectives — like seeing this military infrastructure as a castle floating in the sky — we aim to resignify it and trigger new relationships with the neighborhood.

Luz Auyon + Daniela Beraún

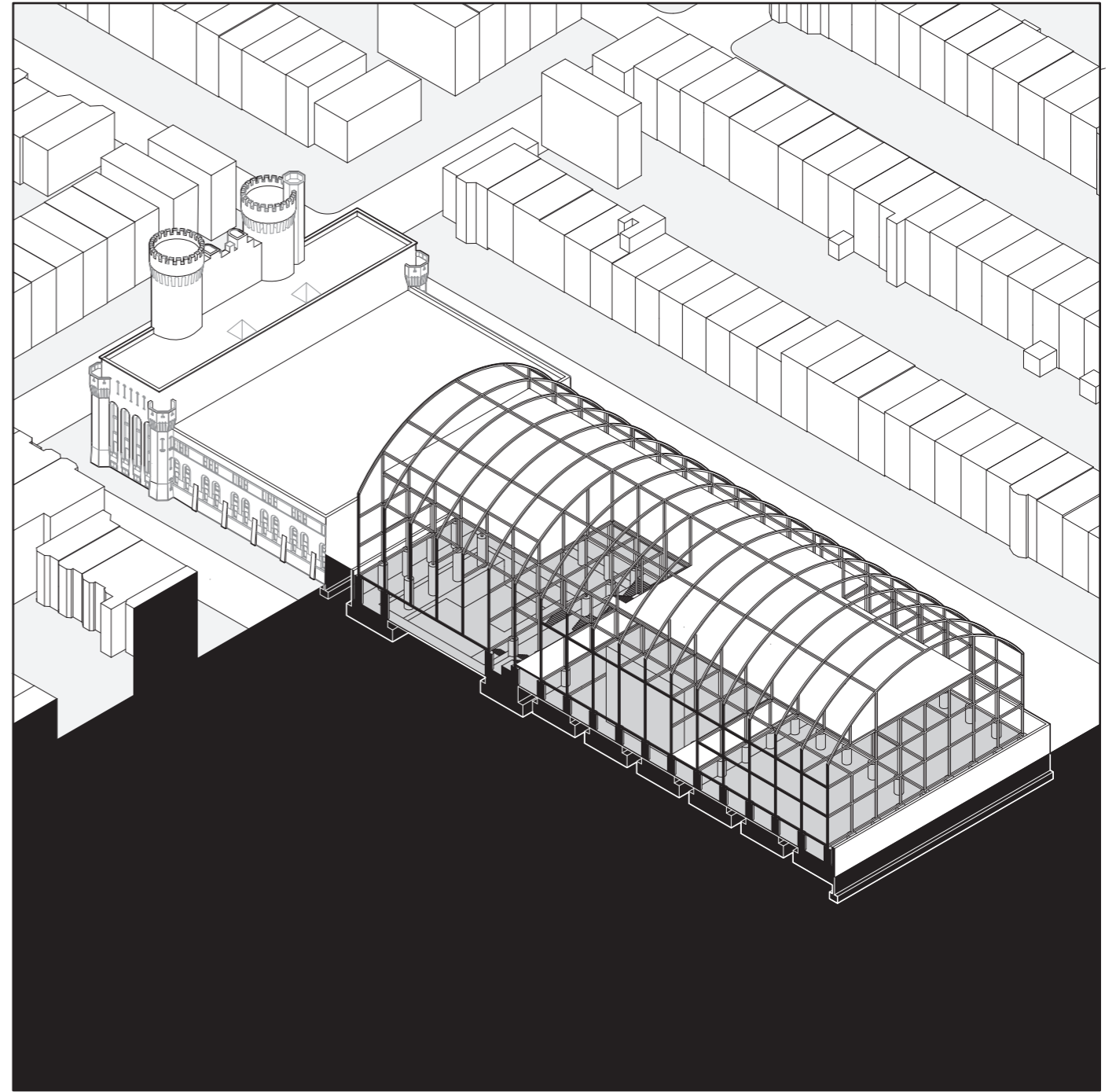
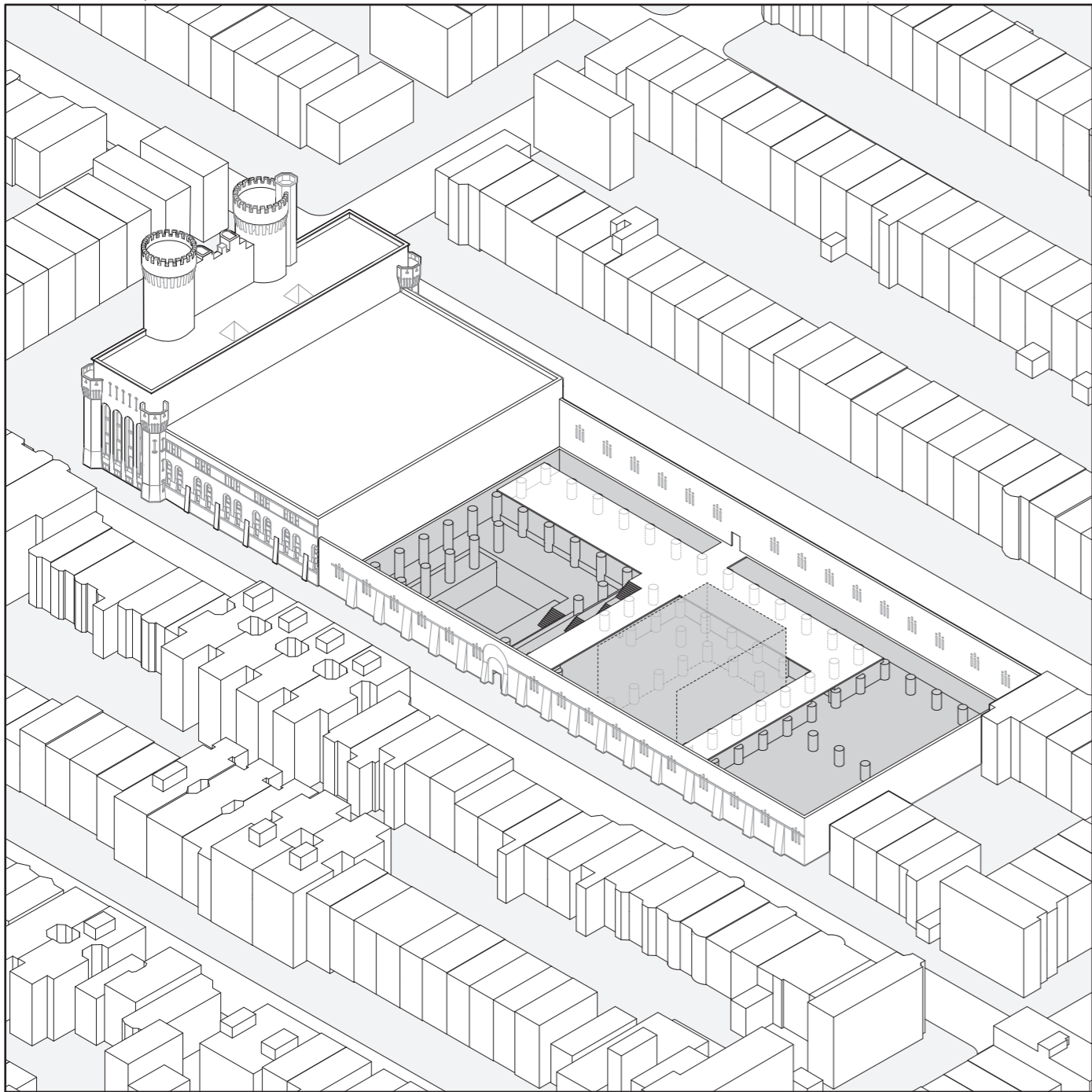

The concept of the project is multiplying the sense emptiness of that space, so that the Armory remains a big – almost block size – void in the middle of the urban density of Bed-Stuy. In that idea, we developed the project following two strategies: excavating to actually create more empty space, and avoiding building a mass above the ground floor level.

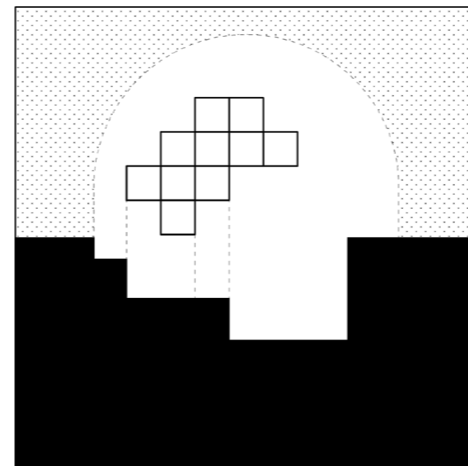
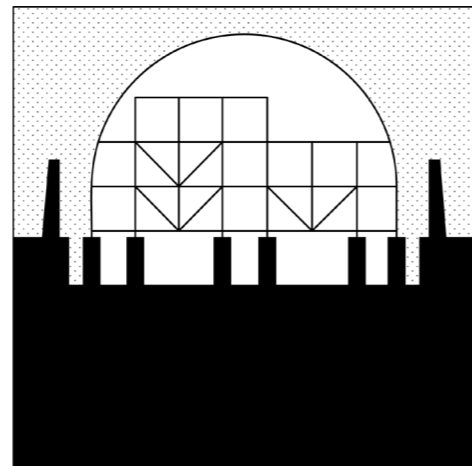

1. Multiplying the void by excavating and by avoiding building mass above ground

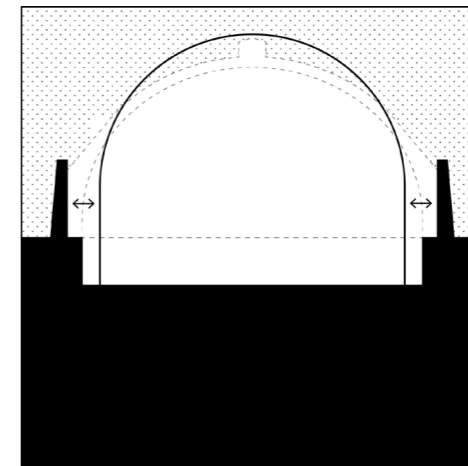

2. The relationship with the existing building is also through voids.

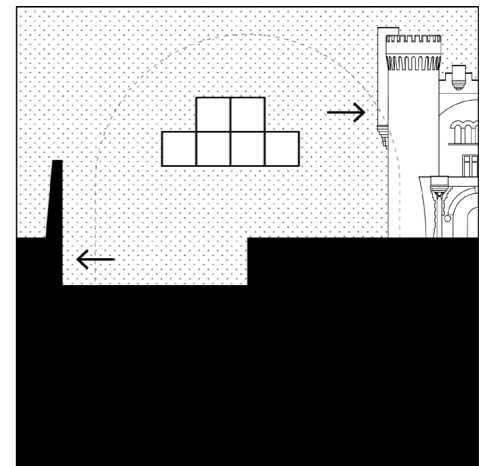

3. The project develops two distinct types of relationships with the preexisting building: the ground and the sky.

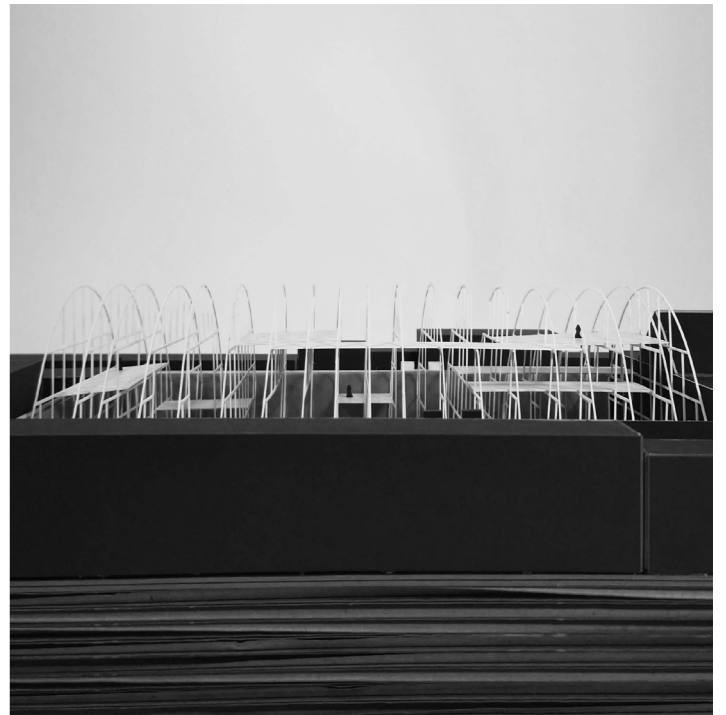
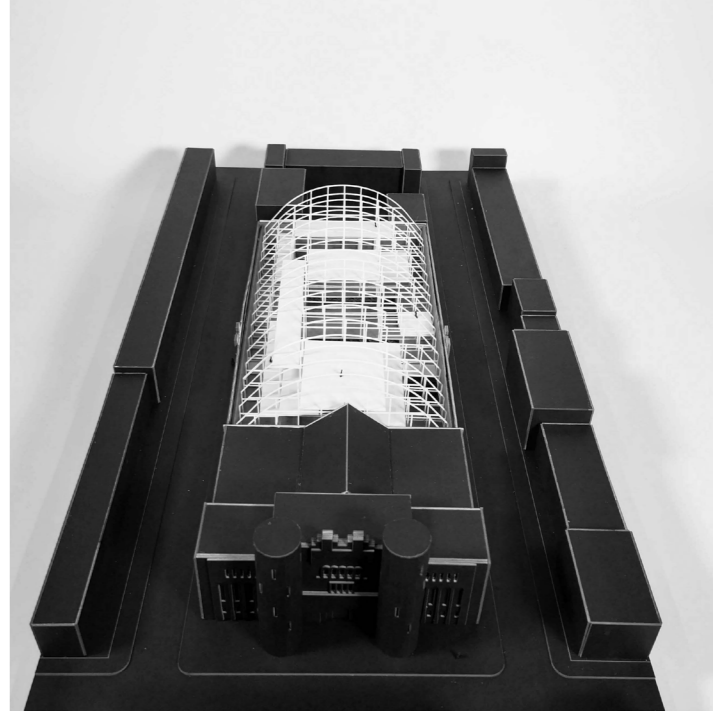
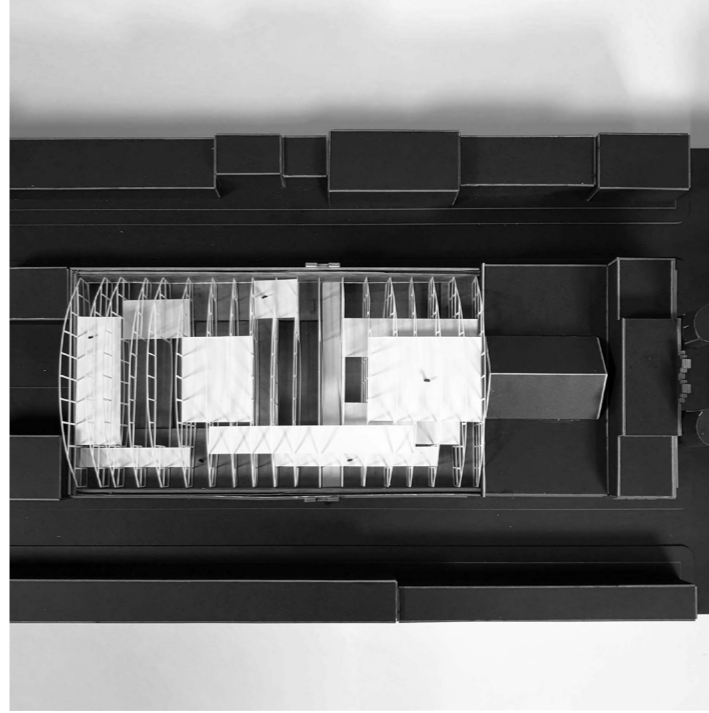
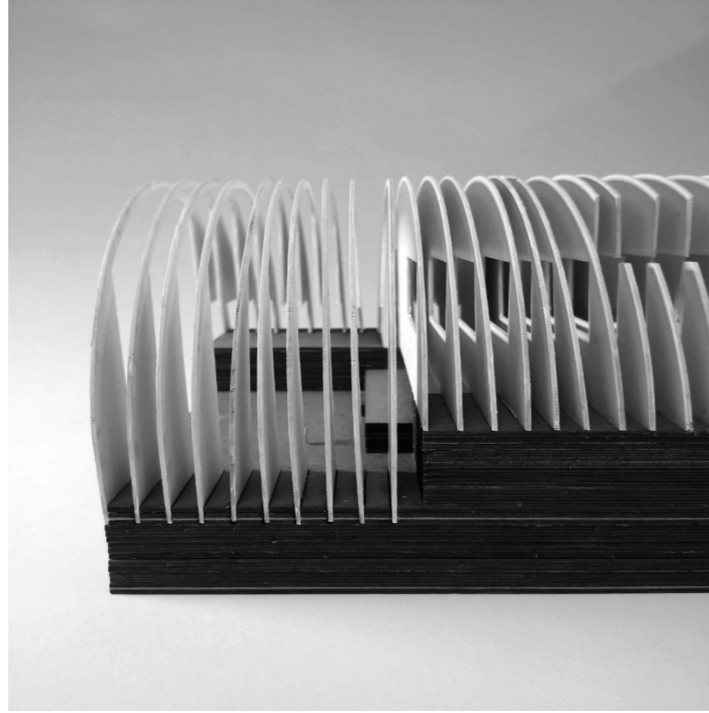



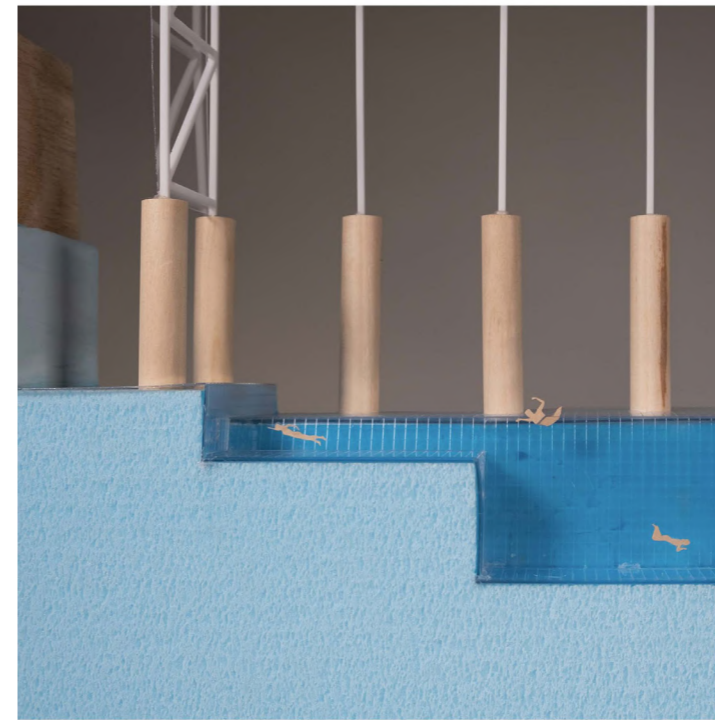
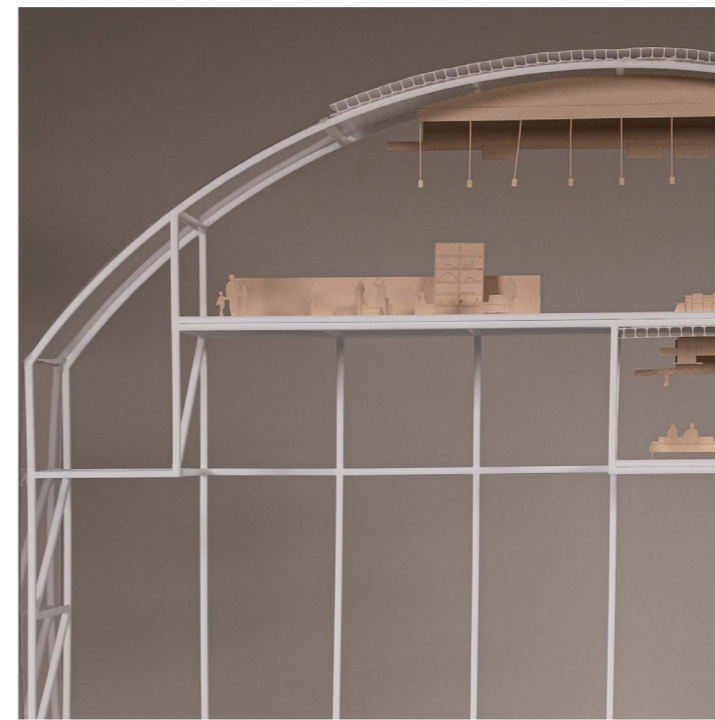

The spaces below the ground floor have a more tectonic relationship to the site. To reinforce this, the entire underground floor, cylindrical columns, and contention wall besides the historic walls are made of an ocher-tinted concrete. Above the ground floor level the architectural language changes to an airy metallic structure that allows the sense of void in the interior. The old trusses of the historic building were replaced by a thinner, lighter 30x30 steel grid structure that sits in the cylindrical columns. Within the grid, there are big voids, such as the one for the sports courts, or slabs that host a more flexible program such as the art gallery.

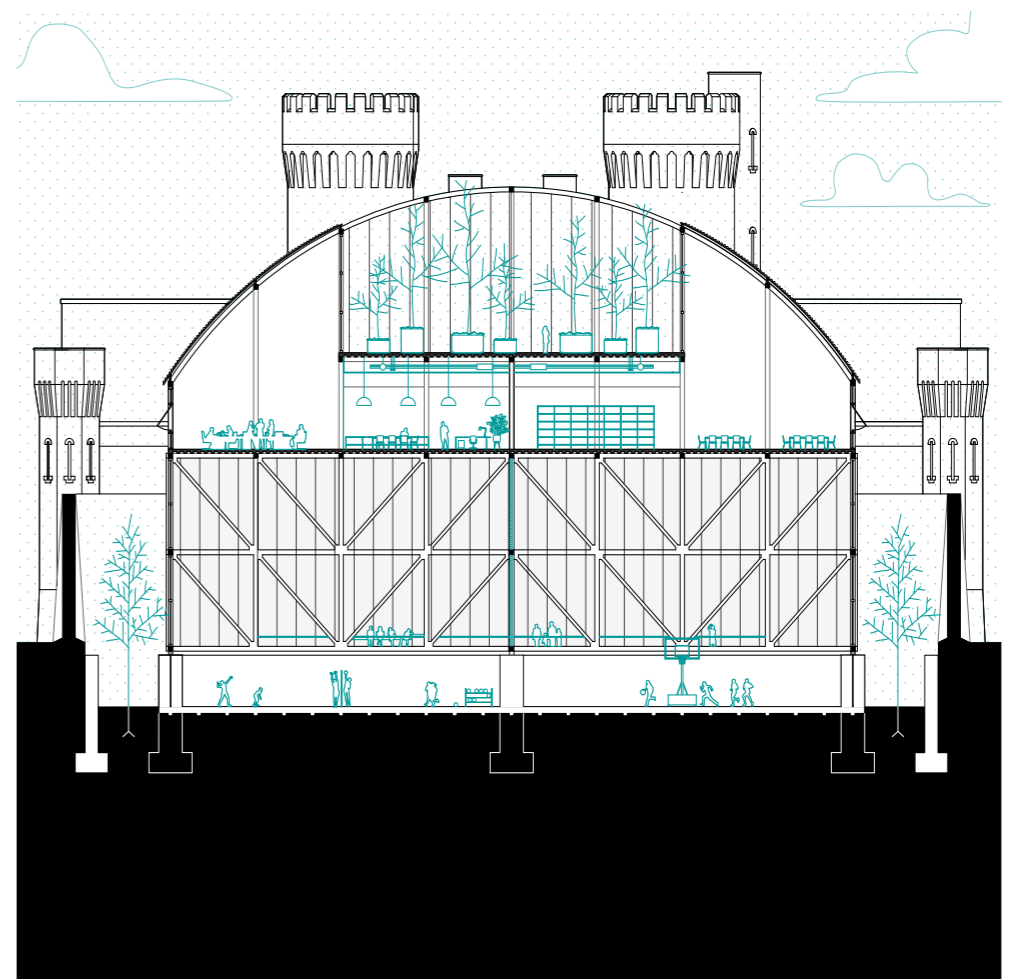
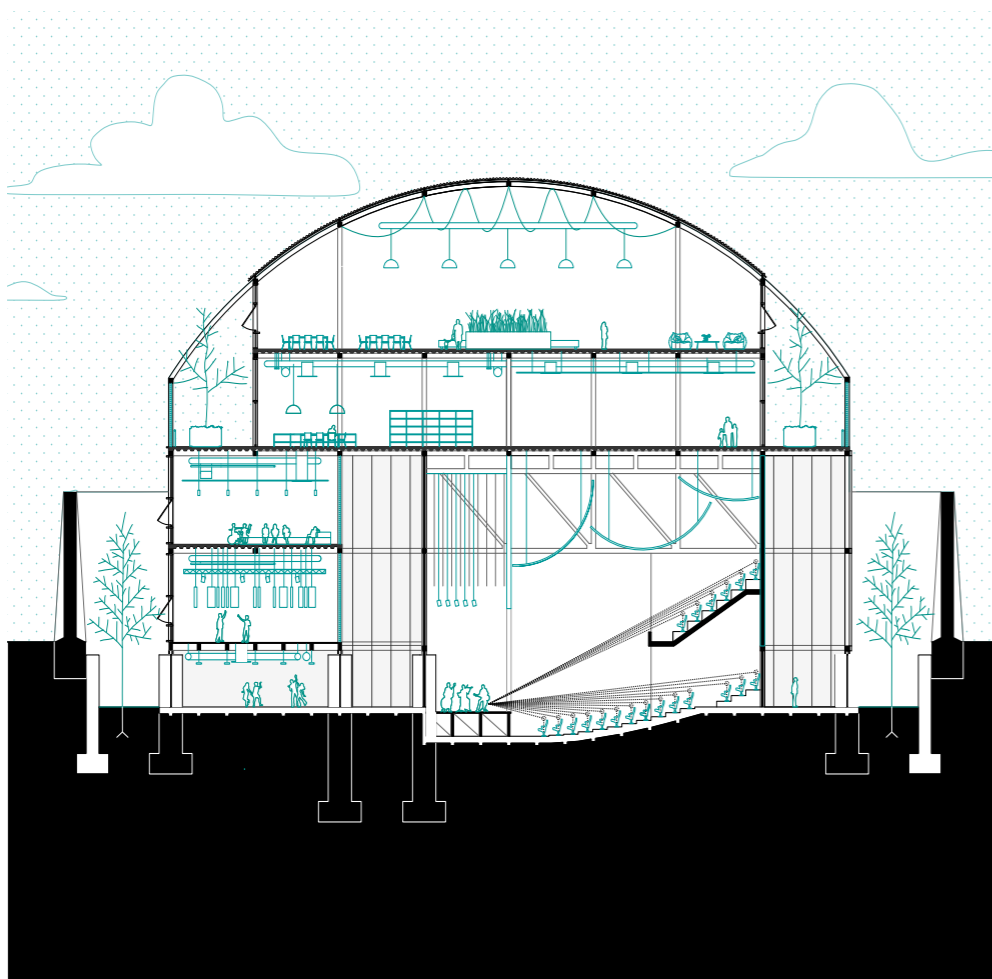
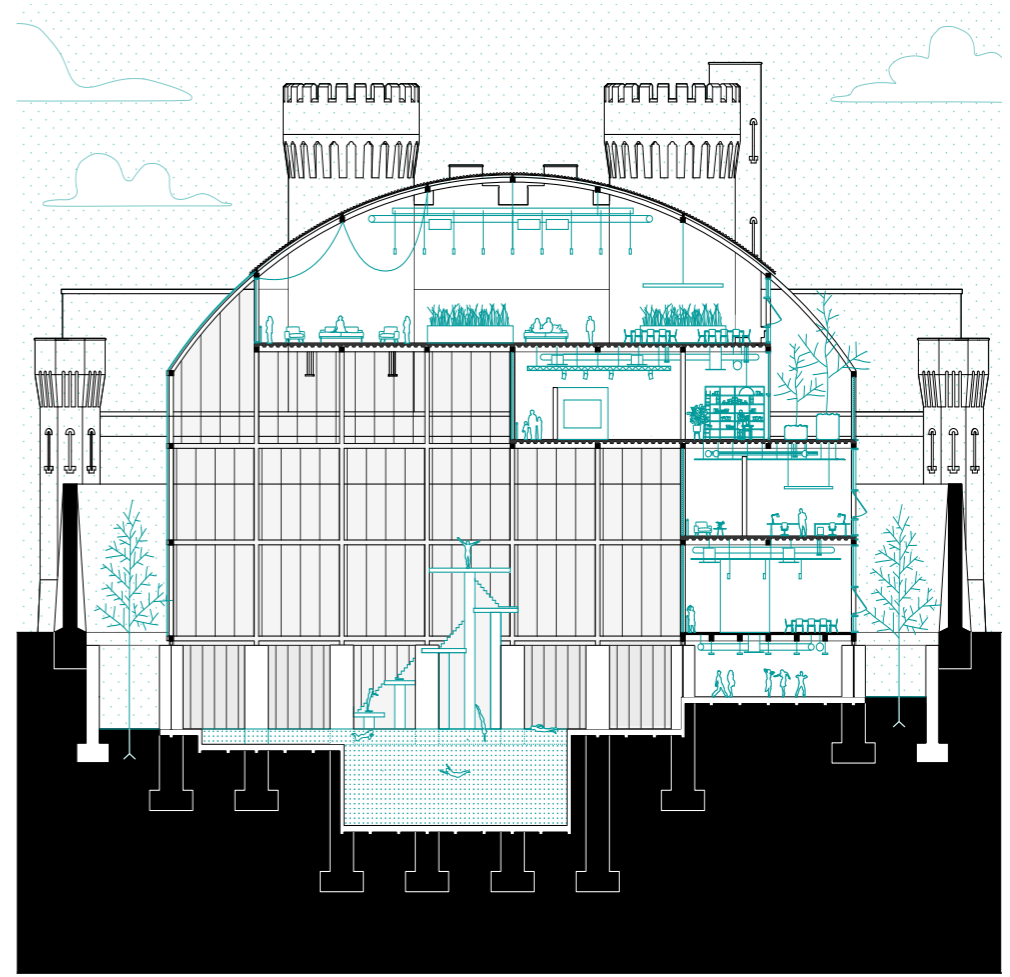
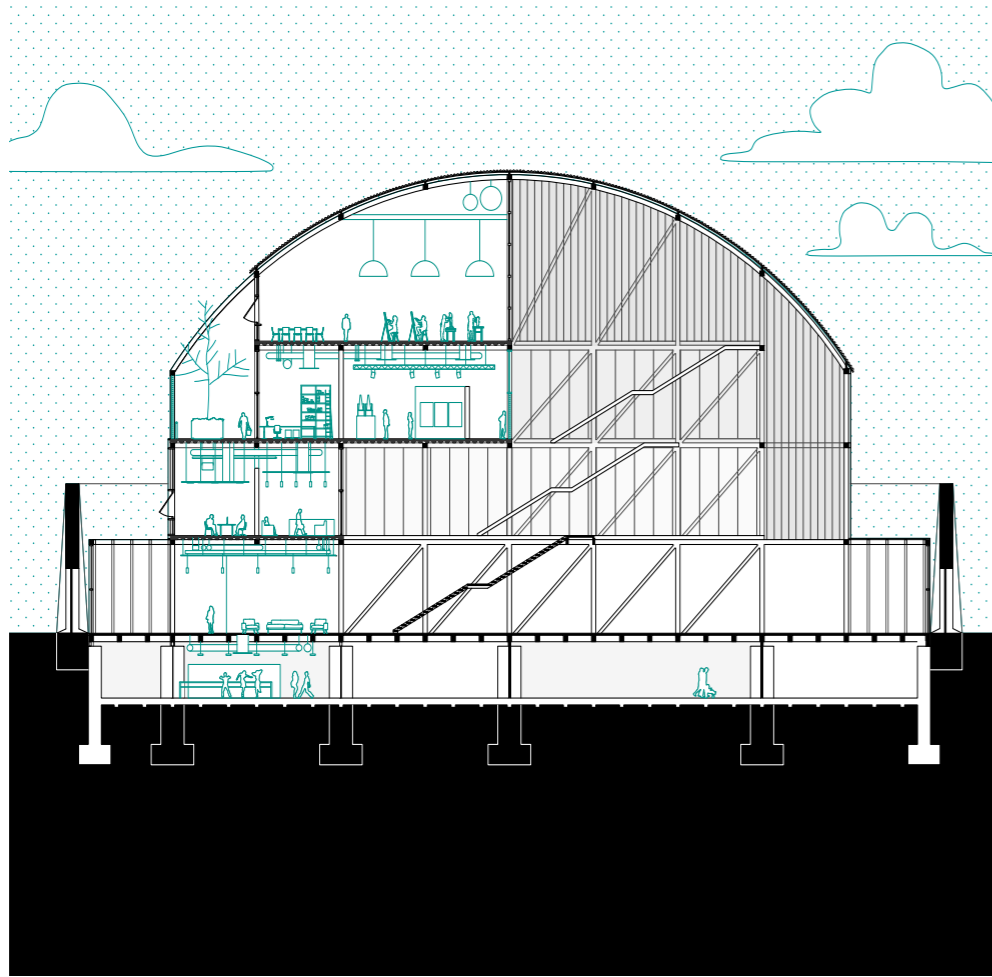

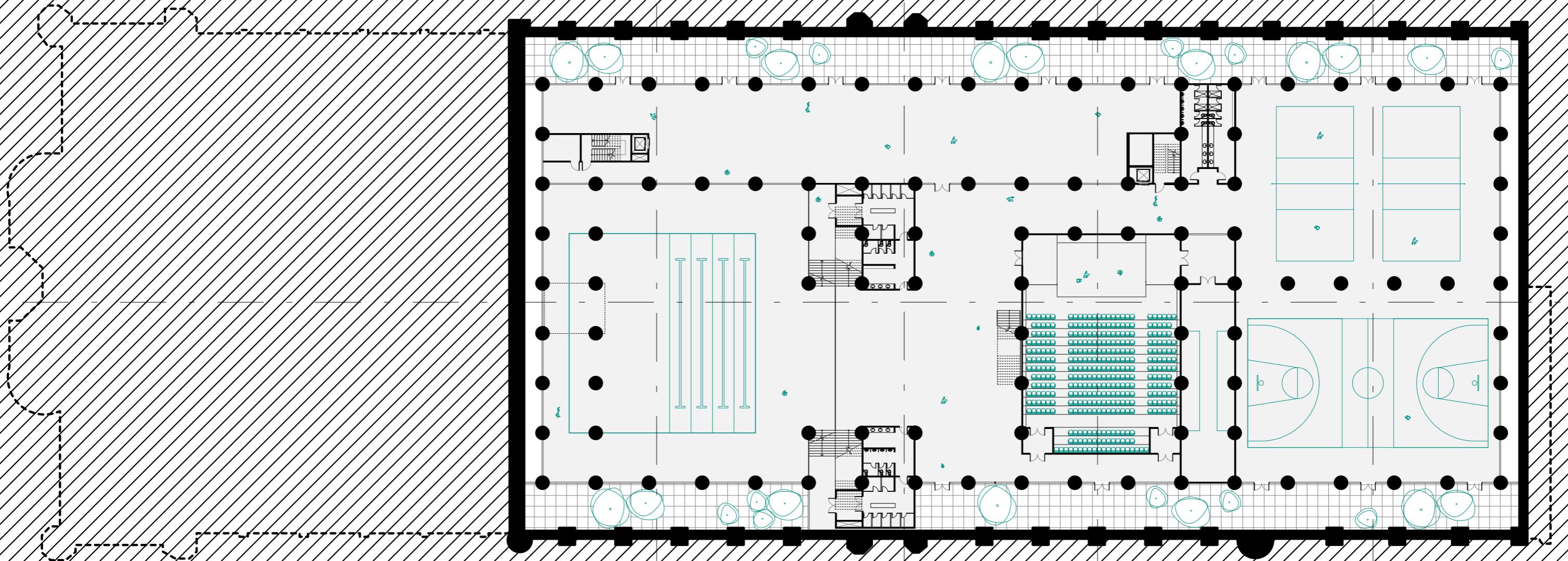



Debunking participatory processes in Latin America

The fragile political, economical and institutional condition of most Latin American countries can easily turn participatory design's noble intentions into a systematic way to perpetuate existing power dynamics. When the participatory process becomes a goal in itself, it gets devoid of its capacity to empower communities and to expand democracy. I see two particular situations we need to be critical about in relation to this. First, when participatory design turns into an aesthetic preference: fragmented, deconstructed, recycled, put together – what we will call scarcity aesthetics. And second, when participatory design is used to support political agendas in lack of better theoretical ground or as a straight up populist tactic.

At its best, participatory design is a form of resistance from the traditional notion of architecture detached from building, and from the figure of the architect as a hierarchical, commanding individual. After the social upheaval of 1968 around the world, and continuing through the first half of the 1970's, it became clear that people wanted change. In architecture, this meant a shift from traditional sources of knowledge towards learning from the broad spectrum of actors involved in building, as well as from “bottom-up” developments. Several movements influenced by the social uprisings – situationists, critical region-

alism, student-activists, advocacy architecture, phenomenological affects, the vernacular, etc – saw the architect as a facilitator rather than as someone that aims to represent perfect societies through the purity of forms.

In Latin America, participatory design is inseparable from processes of urbanization and their links to social development and justice. There are many success stories about communities being empowered by the process of building. For instance, when Villa el Salvador established itself in the state-owned desert land in southern Lima in 1971, CUAVES (Comunidad Urbana Autogestionaria de Villa el Salvador) was responsible for block and neighborhood development as well as planning and management of the whole settlement. This community organization was crucial for people from Villa el Salvador to be able to determine their own future and to force the Peruvian government to support their decisions and actions.

Historically, self-help developments in Latin America have been fueled by the prevailing housing crisis and the limited capacity of governments to provide solutions. The lack of viable plans sometimes gets justified by the romanticization that goes along with the narrative of self-building as idiosyncratic of Latin American

people. The problem is that the idea of something being a “natural” outcome discourages any questioning and, ultimately, the possibility of change. As Karl Popper mentions in his book “The Poverty of Historicism”, the belief in the “historical destiny” – that is, the idea that history has an inevitable force that prevails over individual choices – has been used by autocracies to justify the source of their power and the validity of their ideas. Thinking of self-building as something “natural” for Latin American culture risks being caught up in the same tacit compliance, and not looking into the deep rooted inequalities, like access to land ownership, that go back to colonial institutionalized racism and perpetuate regimes of precarity.

Without the reallocation of power, public policies tend to perpetuate the broader economic and political system. In Peru, despite some successful cases like the aforementioned, the most persistent housing policy of the past sixty years has been the promotion of individual lot ownership through mortgage credit and subsidies to buy construction materials. The development of new towns in parallel to the expansion of credit capacity is a pro-market strategy widely supported by right-wing politics, international capital and global agencies. However, it can be debated if self-build as a product of the market

diminishes its capacity to empower communities. Devoid from its capacity to organize underrepresented citizens in a politically meaningful way, participatory design becomes just a pragmatic solution to the problem of building in regimes of scarcity. This could lead to governmental agencies to perform like bottom-up organizations, reducing their responsibilities and investment in public spaces, housing, etc.

Spending less and building with low quality materials and construction systems has become an extended practice for many public projects in Latin America. Many of them still exploit the aesthetics of participation in lieu of the lack of any critical imagination of a better city. The aesthetics of scarcity become a style that builds up a polished version of current times and current systems, derailing the attention from important questions. In the Quinta Monroy project, for example, Elemental was working for the Ministry of Housing and Urbanism (MINVU) of Chile. The project is an enactment of neoliberal policies, where location – or potential market value – is favored over material quality. The aesthetics of scarcity, in this case, is a palliative for the fact that the houses are, in fact, half-houses because the concept of the project is an economic calculation. The scarcity aesthetic of this project is also a very tangible embodiment of the same neoliberal system that redirects the cost

of finishing the project from the government to the residents, most likely in the form of credit.

Another reason why we need to be critical about participatory processes is the risk of them being used to support populist agendas. Broken democracies can turn participatory design into a propaganda machine to appear more democratic than they are. For instance, Gran Misión Vivienda, a program from the Venezuelan government to provide affordable housing is framed as to “guarantee the protagonic participation of the communities”. Not so coincidentally, projects built under the program, like the Urbanismo Santa Rosa residential complex in Caracas, use the architectural language of scarcity as to signify democratic ideals that are never fulfilled in reality, neither in the project itself and its participatory intent, nor in the political project of the nation as a whole.

It is difficult, though, to identify real life situations as fully populist, or as “truly” participatory, even with a rigorous oversight of processes and an acute understanding of the local political climate. Complex projects often operate in gray areas. Participatory processes can be strategically designed to make a community feel heard without there being a clear strategy on how to assimilate the information afterwards, or to simply

mark a check at an administrative level. Certainly, there are also instances of just failed attempts at incorporating participation into a project. In either case, participatory processes could be deliberately used to, for instance, green light projects that do not have the support of communities, or support reelection campaigns with public resources, while sustaining a false narrative of community empowerment.

Needless to say, not all participatory processes would end up perverted by broken democracies or corrupt politics. But we need to be aware of the precarious dance between what we hope these processes can achieve, and how they really operate within complex political and power dynamics. Nowadays, we cannot assess the success or failure of participatory projects based on their ability to solve the housing crisis, as was the intention of the early 1970’s projects. Instead we should hold them accountable in their capacity to organize and maintain political representation for diverse groups of people. Despite everything, true participation can still be a powerful tool to empower communities and to expand democracy.

Bibliography

Álvaro Suzzarini Fernández. 2021. El plan chavista de construcción de vivienda social a diez años de su creación. Agencia Anadolu.

Arturo Valladares. 2017. Successes and failures of participation-in-design: Cases from Old Havana, Cuba. *Frontiers of Architectural Research*, Volume 6, Issue 3, 2017, Pages 401-411

Bertha Turner. 1988. *Building Community: a third world case book*. Building Community Books, London.

Camillo Boano, Francisco Vergara Perucich. 2016. Bajo escasez. ¿Media casa basta? Reflexiones sobre el Pritzker de Alejandro Aravena. Facultad de Arquitectura y Urbanismo de la Universidad de Chile: *Revista de Arquitectura* Vol. 21 · N° 31 *Arquitecturas colectivas*.

Helen Gyger. 2019. *Improvised Cities : Architecture, Urbanization, and Innovation in Peru*. University of Pittsburgh Press.

Ellen van Holstein. 2018. Experiencing opportunity and discrimination in participatory urban planning projects in bogotá and Medellín, Colombia.

Jencks, C. 1984. *The language of post-modern architecture*. New York: Rizzoli.

John Turner. 1963. *Architectural Design 8 Magazine*. Articles: “Dwelling Resources in South America”, “Turner, Minimal government-aided settlements”, and “Urbanization case history in Peru”.

Ricardo Bofill: situated practice

Designing, building, painting, drawing, teaching, curating, directing, acting - whatever might be the practice of an architect - is a carefully designed project. These three diagrams look into the practice of Ricardo Bofill as a case study to understand how one's practice is place within a network of ideas, people, places, movements, books, etc. Each diagram has a distinct focus. The first one places the life and work of Ricardo Bofill within vertical scale of google searches results. It also locates the projects in a political and geographical context (lower part) and confronts the two most recurrent broadcast activities Bofill engaged with: exhibitions and TV appearances.

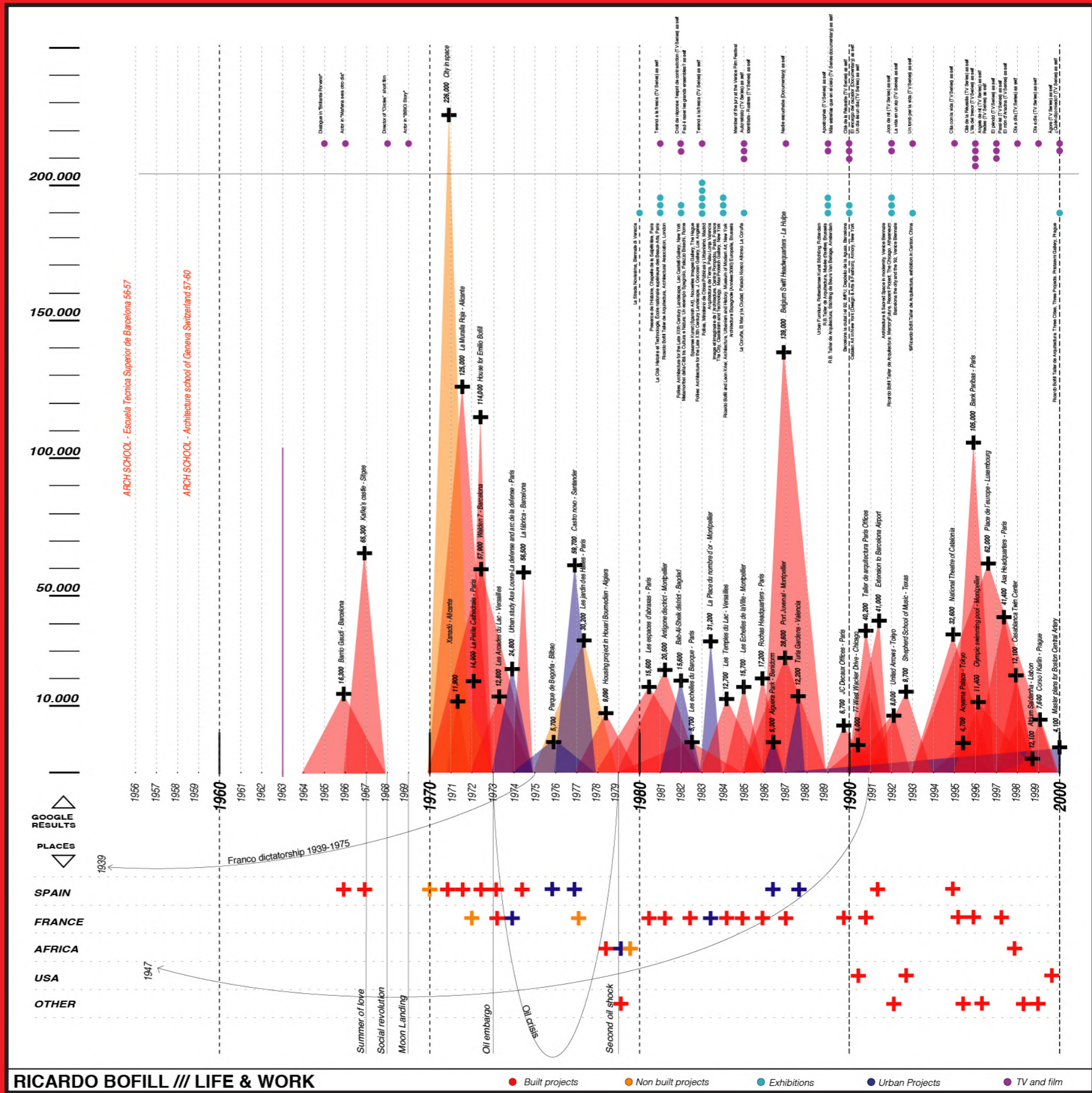

The third diagram places Ricardo Bofill's projects in a context of architectural discourse. This circular timeline places Pritzker prize winners, MOMA exhibitions, Venice biennales, and CIAM conferences in context with crucial texts and buildings of architectural history and theory. On the outer part of the diagram, the practice of Bofill is also placed chronologically with the idea of making connections between the projects and the discourse, which in this case only happens around the first Venice Biennale of 1980.

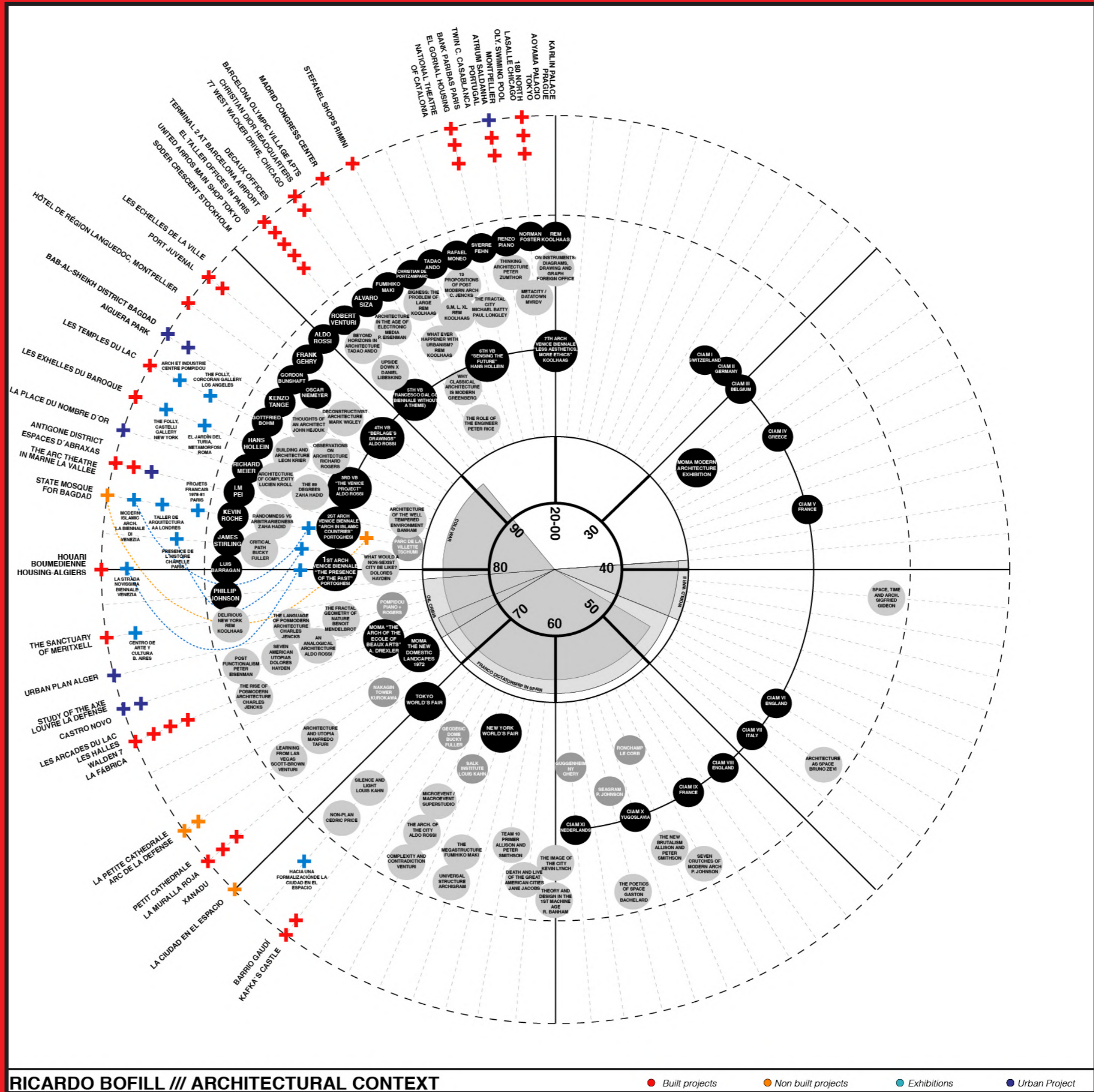

Post-school childcare infrastructures



This project imagines how we can challenge the school system that remains heavily segregated through a series of infrastructures for after-school activities. The aim of the project was to shift to forms of coalition based on interests rather than on where people live, and it was inspired by models of peer to peer care such as those at play in summer camps. These infrastructures connect existing afternoon activities offered by organizations throughout the city in a network accessible to kids regardless of where they attend school.

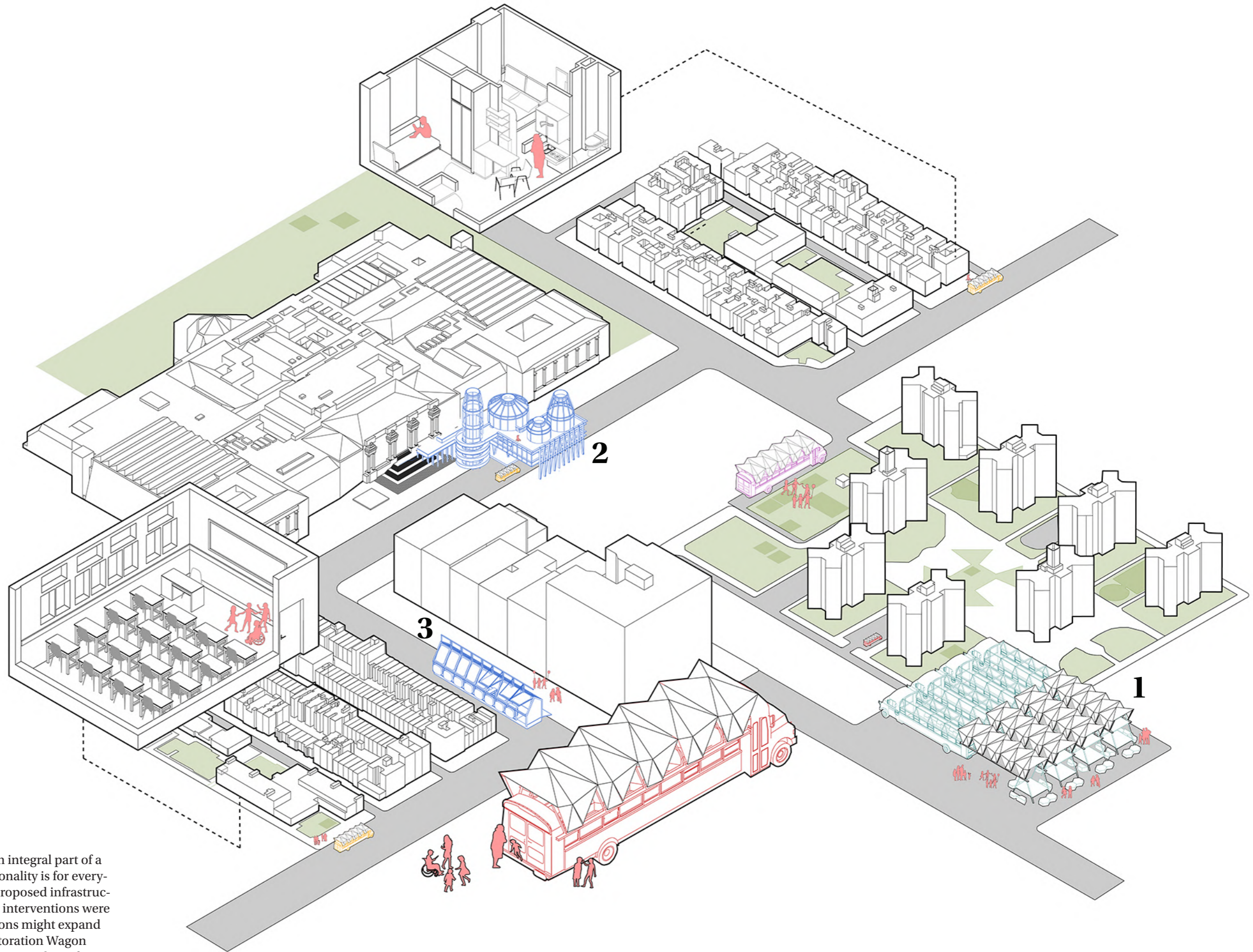

This project looks at afternoon activities as an integral part of a system of decentralized learning, where optionality is for everyone, not a luxury. To achieve this, the main proposed infrastructure is an after-school bus system. Two other interventions were also designed as examples of how organizations might expand their specific programs for children: The Restoration Wagon was designed for Jewels of Harlem to reinforce a reading after-noon program, and the “MET Accessible!”, is an installation that puts a helical ramp in the main entrance of the MET, and adds spaces that are not subjected to the logics of philanthropy and conservatism of the museum.

1 The post-school bus

2 The MET, accessible!

3 The restoration wagon

Housing Crisis
 NYCHA has more than 174,000 (thousand) families that are on the waiting list for an apartment. Those are 35,000 more families than the ones actually living in NYCHA housing or in private apartments with section 8 vouchers. However, the Tyson family is still number 25 000 (thousand) on NYCHA's waiting list.
 One non-profit organization that works in Harlem towards providing legal representation for accessing housing, tenant organizing, and energy efficiency upgrades to houses is The Northern Manhattan Improvement Corporation. They also provide legal representation to immigrant people and citizenship preparation classes.

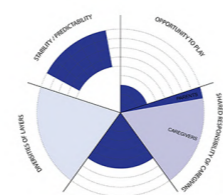

In-home Day Care
 One caregiver may care for a maximum of six children younger than school age, or eight children when at least two of the eight children are school aged.
 When care is provided for children under the age of two years, there must be at least one caregiver present for every two children under the age of two years in attendance.
 Care can only be provided on floors with two means of egress.

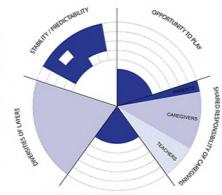

Children Get Sick
 Day care institutions overall have always been a place where children are exposed to each other's viruses, and get sick very often. In a way, a necessary experience to develop a strong immune system. But within the pandemic context, this created a new set of problems such as parents having to take care of their sick children at home, infecting the caregivers, reducing the day care staff, putting a strain on those remaining.

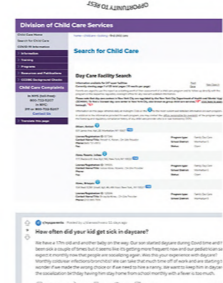

After mass closures and too little support, post-pandemic child care options will be scarce
 News Release from the Heritage Foundation
 Being to work before the pandemic, Valerie Starn based on HR cover about a couple of months ago in the pandemic, people were working at 80% of normal levels for the first time since 2008, when she left the Budget for the Children's Center for 10 years.

Why Child Care Staff Had to Show Up While Teachers Worked Remotely
 The pandemic has spotlighted disparities in working conditions between childcare workers and teachers.



Gender Roles
 Child care in general, but especially when it's placed in the realm of the house, is intersected by traditional gender roles which establish women as the main care provider.
 This directly translates to the demographics of caregivers in general: 91% of domestic workers are women, especially african-american women who represent 21.7% of domestic workers, compared to 11.9% of workers in other industries, according to the Domestic workers chartbook from the Economic Policy Institute.

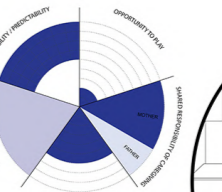

Why Women Still Can't Have It All
 It's time to stop blaming ourselves, says a woman who left a position of power the moment she became a mother and big professionals are superhuman, rich, or self-employed. If we truly believe in equal opportunity for all women, here's why...

Homepage | National Domestic Workers Alliance
 The National Domestic Workers Alliance (NDWA) works for the respect, recognition, and rights for the nearly 2.5 million nannies, housecleaners, and home care workers who do the essential work of caring for our loved ones and our homes.

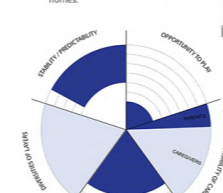

The domestic workers alliance is an organization that works to develop policies, innovation through technology, data collection and mobilizing voters nationally, to protect domestic workers and better their labor conditions. Moreover, domestic labor altogether is excluded from economic measures like G.D.P., while they are considered to be essential workers.



Research in collaboration with Chiun Heng Chou and Bingyu Xia

Why It's So Hard to Stop Being Homeless in New York
 The city spends \$1.2 billion a year on homelessness. Yet the crisis only gets worse. Eight homeless New Yorkers explain why.

Free Breakfast
 As Jerry "Odinka" Dunigan, a leader of the party, puts it: "It was extremely exhilarating to feed the children. You saw the future in their faces, and you wanted to be right for them".

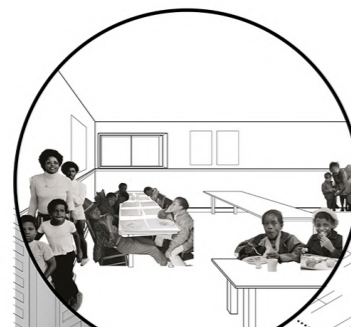

P.S. 76 A Philip Randolph		Anderson School (The)	
Enrollment	13,7	Enrollment	17,5
Number of students	375	Number of students	522
Enrollment change	97.6%	Enrollment change	98.0%
Enrollment per capita	75.2%	Enrollment per capita	40.0%
Enrollment per square foot	14.4%	Enrollment per square foot	11.7%
Enrollment per acre	3.5%	Enrollment per acre	8.9%
Enrollment per square mile	97.6%	Enrollment per square mile	12.1%

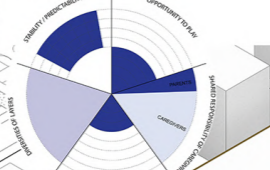

Reading Circle
 The Reading Circle program is structured around three free libraries and book clubs in Madison Square Park. Artist Susan Starr designed the library book club creating the murals depicting the Five Wives of the Circle, Public Art Installation Initiative.



This project embraces the possibility of remote school as a permanent option to challenge the house-school binary, that is many times unable to respond to the needs and sensitivities of all kids--such as with LGBTQIA and disabled kids. In this context, the after-school activities become the necessary complimentary space where children socialize, move, play and learn.

The post-school bus

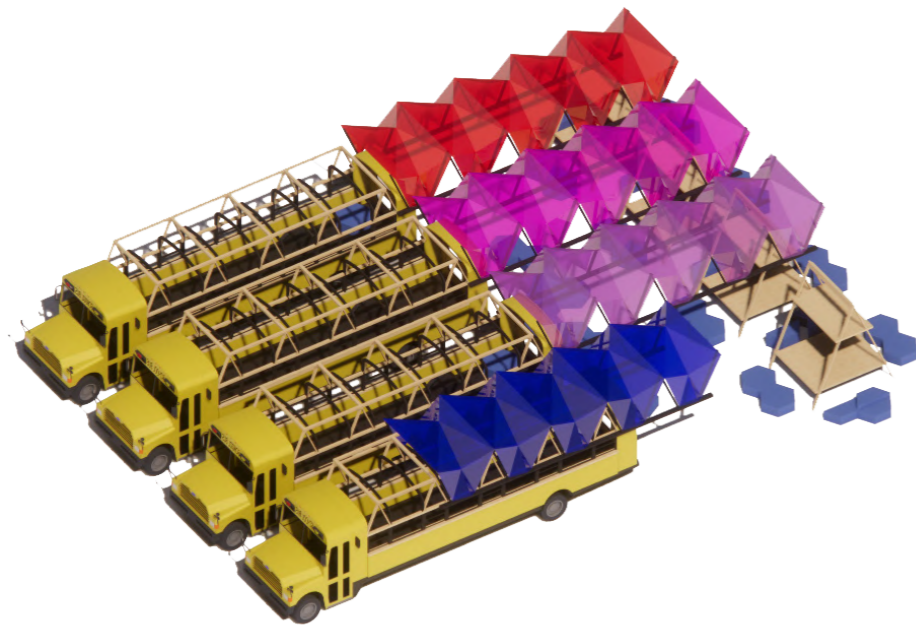
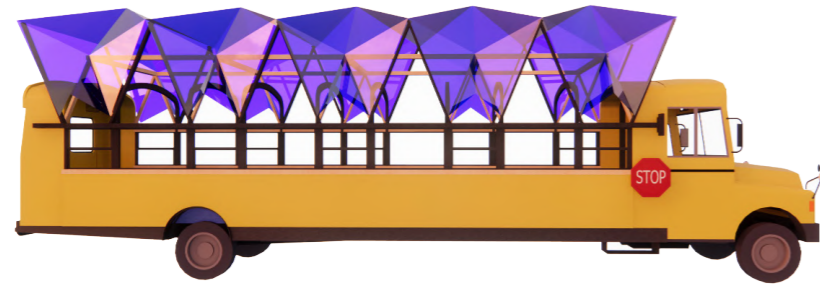

Historically, school buses have played an important role to fight segregation. Currently, the city has a plan to replace them with smaller electric units by 2036. In this proposal, the old school buses would be reconverted into afternoon buses. Every organization, with sponsorship of the city, would own a customizable bus. Children would have the option of taking a different bus every afternoon, joining diverse activities throughout the week, or they may choose to take the same one everyday and start forming coalitions based on their interests. Also, the sliding roof allow the buses to further decentralize afternoon activities by occupying public spaces.

AFTERNOON BUS STOPS

Updated Harlem stops for the 2021-22 school year | Run Monday - Friday from 3PM to 4PM

<ul style="list-style-type: none"> +Morningside Park +St. Nicholas Park +Jackie Robinson Park 	<ul style="list-style-type: none"> +Harlem Children Zone +Boys & girls club of Harlem +Jewels of Harlem +Harlem Commonwealth Council +YMCA of Greater New York/Harlem Branch 	<ul style="list-style-type: none"> +PS 241 Family Academy +PS 129 John Finley +PS 76 Phillip Randolph +PS 125 Ralph Bunche +PS 149 Sojourner Truth +PS 185 Early discovery
--	---	--

NYC City Camps | If you want your organization to participate call (718) 922-3855

ACTIVITIES

TIME AND DAY VARIES

<h3>TEAM ACHILLES KIDS NYC RACES & WORKOUTS</h3> <p>MON-WED-FRI 4-6:30PM</p> <p>The running walking rolling programs allow kids with disabilities get the opportunity to exercise regularly and compete with other runners, helping them become stronger and healthier. Equally important, they give children a way to measure achievement at any level of participation, gain confidence through their successes, and have fun.</p>	<h3>THE MET DISCOVERIES WORKSHOPS</h3> <p>MON-FRI 5-7PM</p> <p>These workshops welcome children and adults with a range of developmental and learning disabilities and those on the autism spectrum, together with family and friends. All can enjoy these multisensory workshops that include tactile opportunities and art-making activities. Explore a different theme in each session.</p>	<h3>NYC BALLET IN MOTION WORKSHOP</h3> <p>MON-WED-FRI 5-6PM</p> <p>These one-hour workshops are especially designed for children with physical disabilities and movement disorders. Under the guidance of a medical professional, each participating child will be paired with a volunteer medical student "buddy" who will offer assistance with mobility and stability throughout the workshop.</p>
<h3>MORNINGSIDE CENTER PAZ Program</h3> <p>TUE-THU-FRI 4-7PM</p> <p>PAZ program combine after-school activities (including the arts, science, sports, community engagement, and academic support) with a strong focus on building social and emotional skills and fostering a sense of social responsibility. The program weaves together social and emotional learning (SEL), restorative practices, and racial equity.</p>	<h3>GIRL SCOUTS Girl Scout Leadership Experience</h3> <p>TUE-FRI 4-5:30PM</p> <p>Activities include: First Aid, Arts and crafts, STEM Projects and many more. Furthermore, Girl Scouts have the opportunity to participate in monthly outdoor events/trips. Experience them in a unique way that puts her on a path to a lifetime of leadership, because our program is girl-led, girls decide what they'll do, together.</p>	<h3>JEWELS OF HARLEM Reading, Writing, Respect & Resolution</h3> <p>MON-FRI 5-6:30PM</p> <p>The 4Rs uses children's literature as a springboard to strengthen students' social, emotional, and academic skills. Children are guided through writing exercises, role playing, and meaningful discussion about how the characters handled conflict, how they might be feeling, and what alternatives exist for making new decisions.</p>

Reconversion of School Buses guidelines

CHILDCARE IN NEW YORK
NYC Announces reconversion of School Buses for new City Camps program

Reconversion for afternoon activities on school buses is being released by 4000 units by 2025

What to Know

- 1. The City will be the owner of the bus. The City will be responsible for the bus's maintenance and safety.
- 2. The City will be responsible for the bus's insurance and liability.
- 3. The City will be responsible for the bus's registration and taxes.

Reconversion Guidelines

- 1. The bus must be a 2010 or newer model.
- 2. The bus must be a 2010 or newer model.
- 3. The bus must be a 2010 or newer model.

WHAT DO YOU THINK?

1. Yes, I support this program.

2. No, I do not support this program.

3. I am unsure.

4. Other.

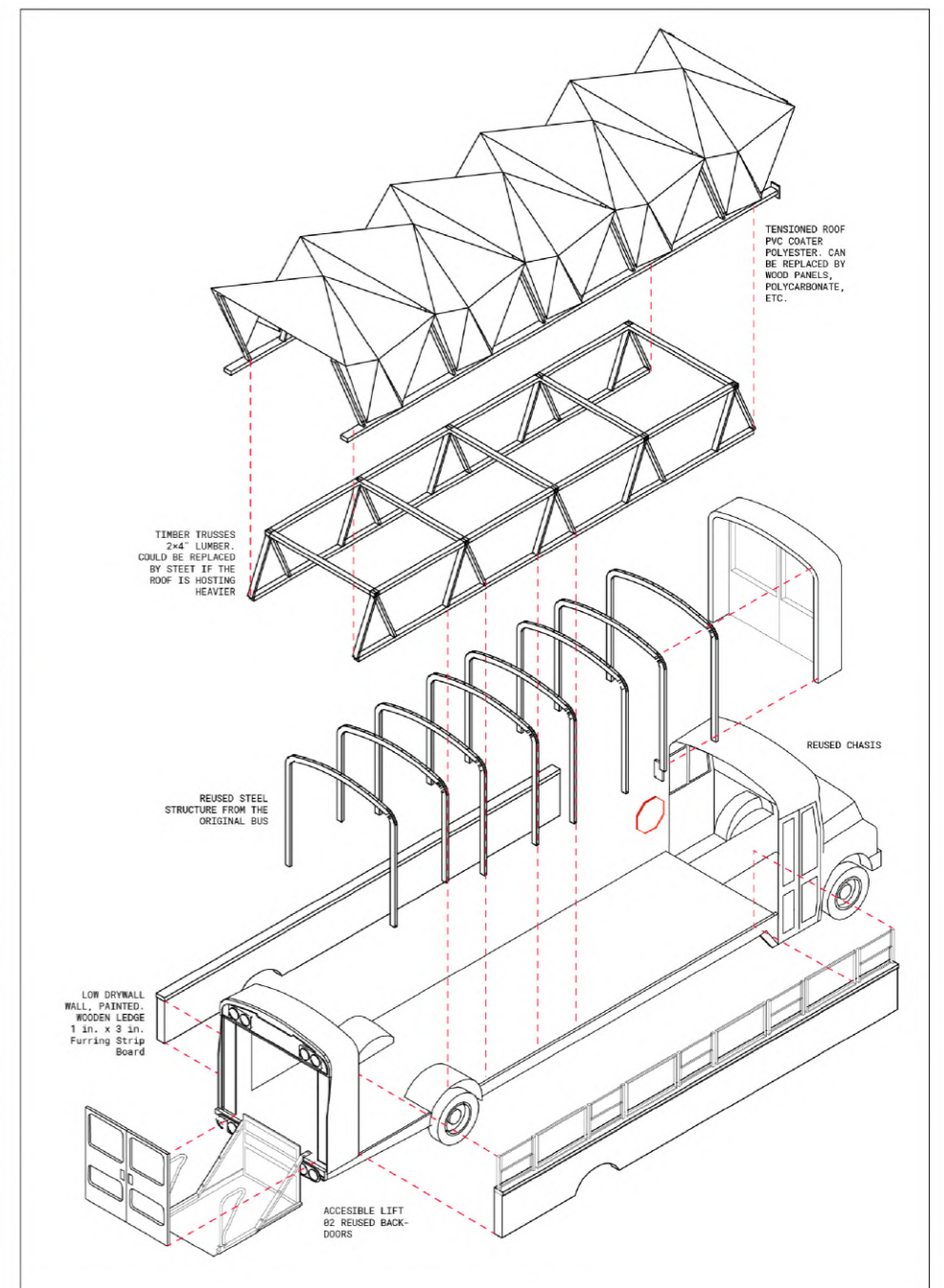



Most of the unit is reused: the chassis, the front cabin, the main structure and some windows. Two steel trusses are added to the existing structure to support the wooden frame of the sliding roof. The interior furniture is movable to allow a more comfortable experience, accommodate children in wheelchairs anywhere inside the bus, and have the possibility of using the outdoor activities.

The MET, accessible!

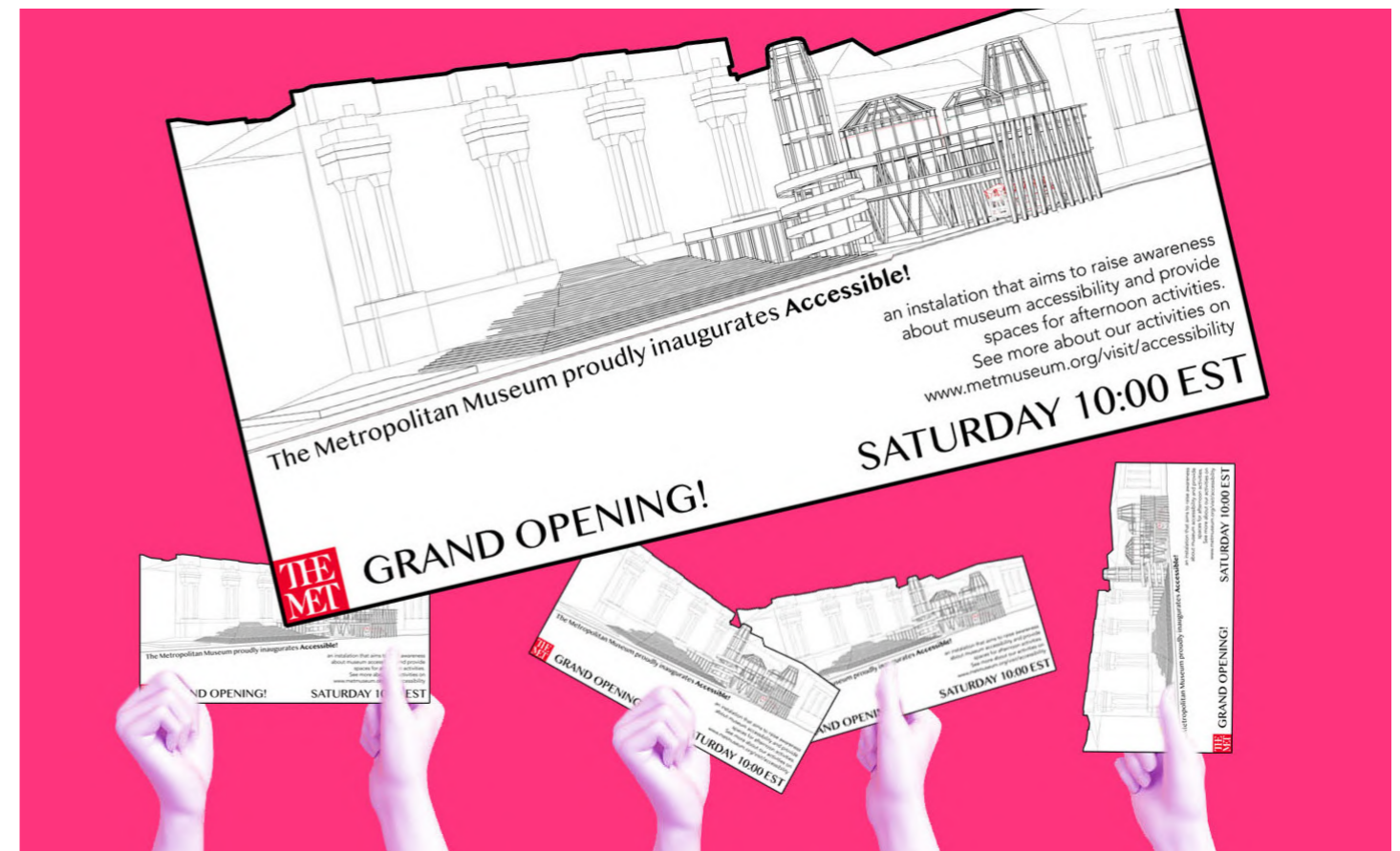
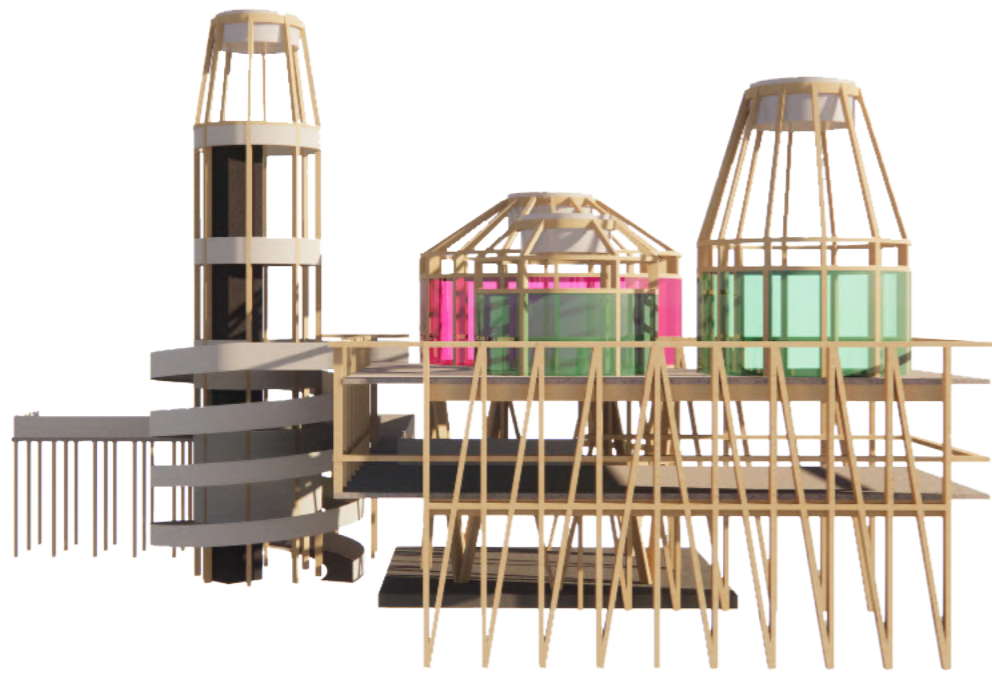

This is one of the two infrastructures that imagine how specific institutions might join the post-school era. The MET has an extensive program for children and for disabled people. This temporary installation is situated in the main entrance of the MET, allowing an accessible access through the main lobby, and adding spaces that are not restrained by the status of landmark the building has. The installation aims to make a statement about the accessibility of museums by taking over the front stairs of the MET, which strongly represent power and status and remain a monument of inaccessibility.

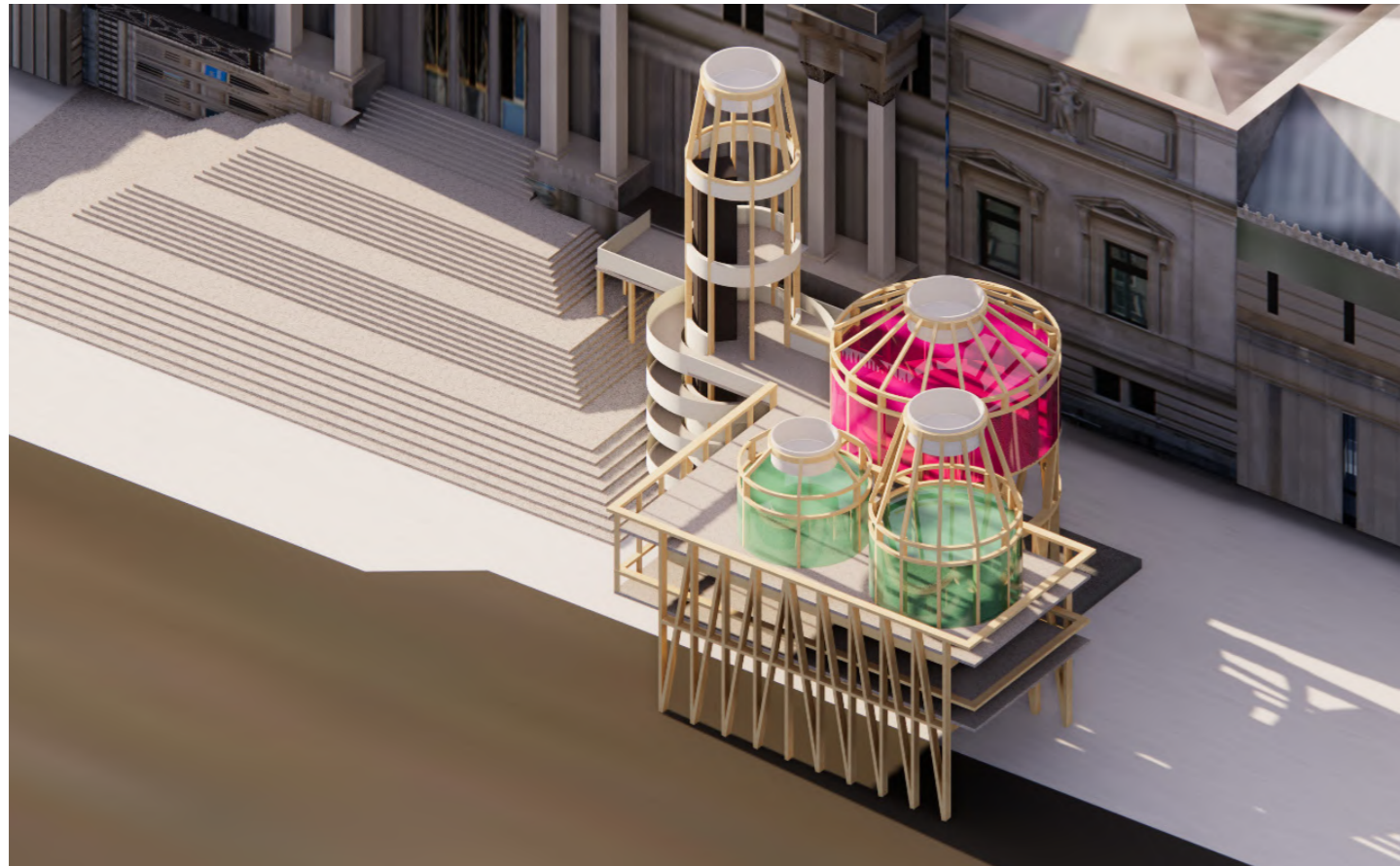

One of the workshops is placed on top of one of the fountains sponsored by David Koch, a libertarian billionaire, to enable the fountain as a place of play, and to counter the logics of philanthropy with a state-sponsored inclusive understanding of education.

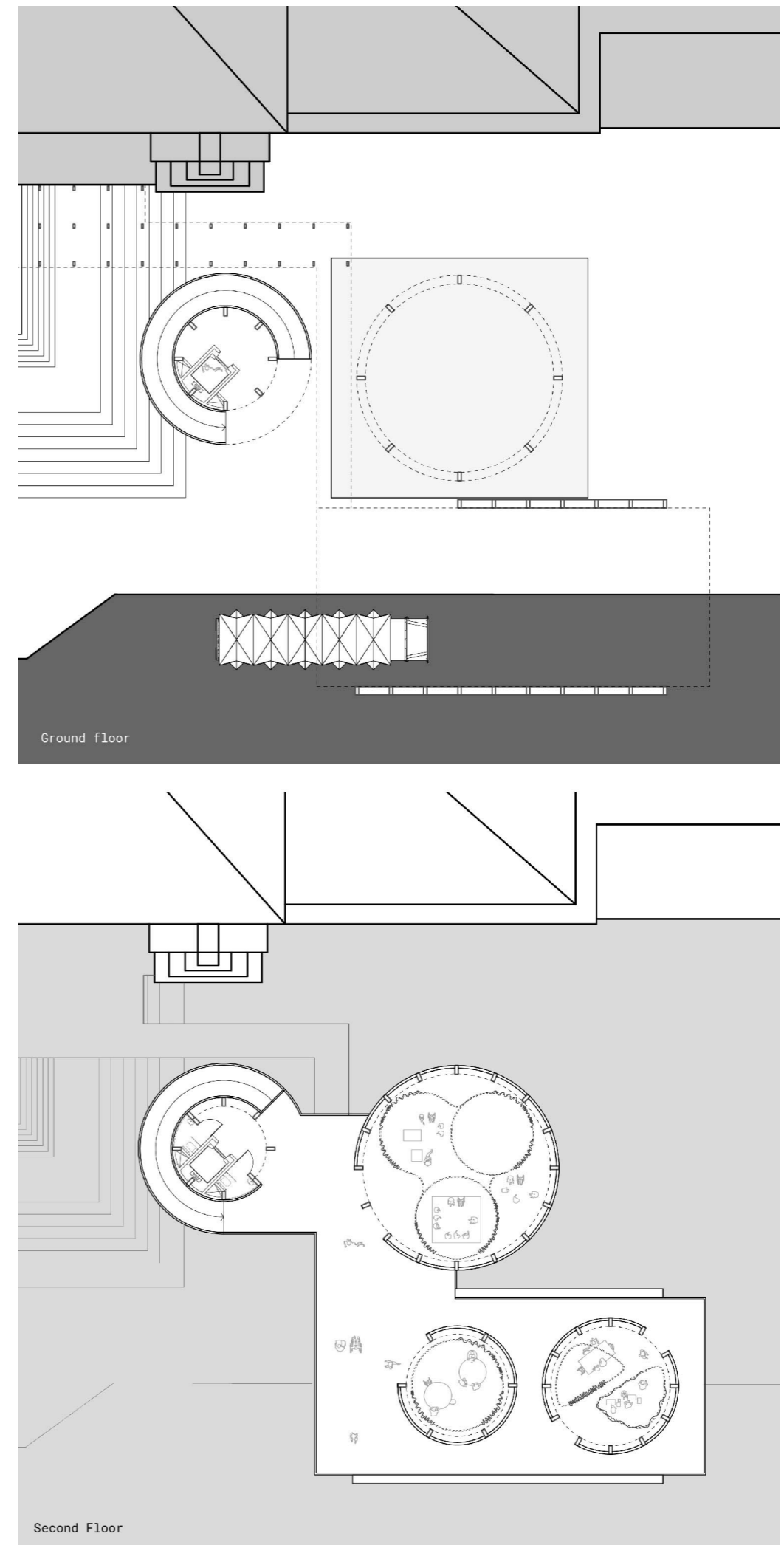



The restoration wagon

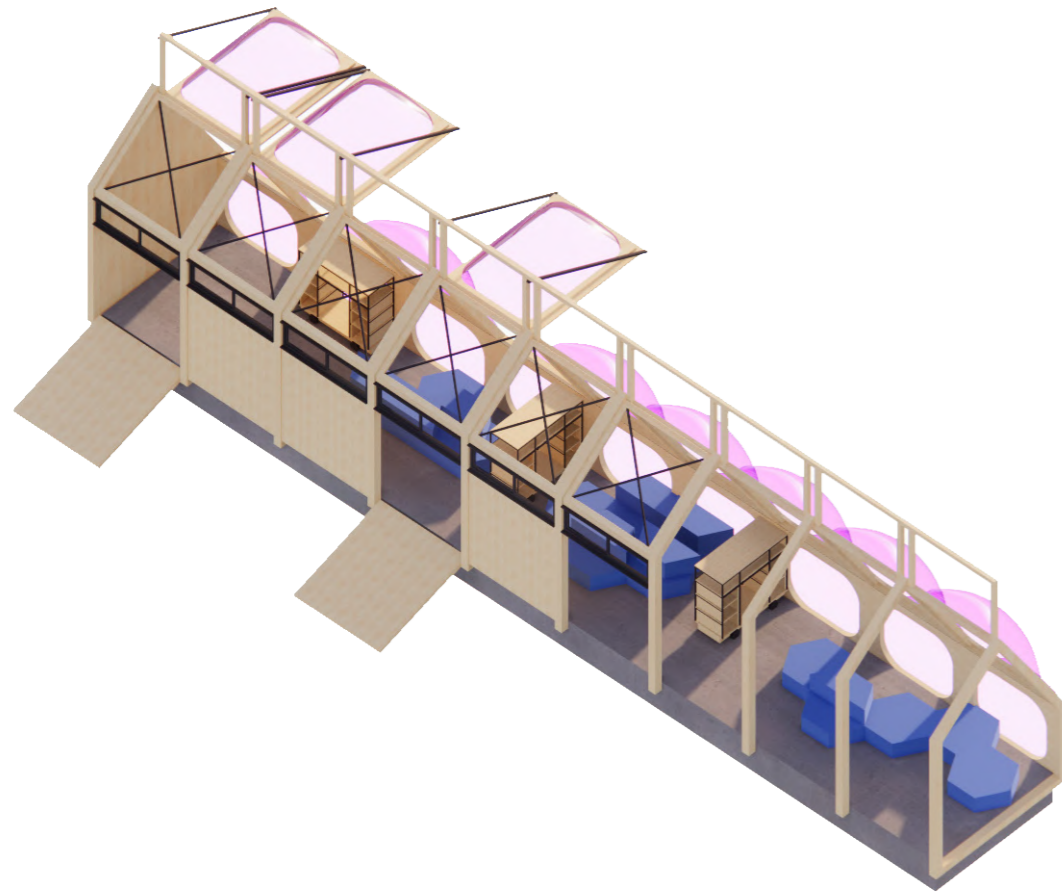

The Restoration Wagon is a small infrastructure designed for an organization called Jewels of Harlem. The project builds on the idea of restorative houses, seeking to create a space for comfort linked to literature, to strengthen social, emotional, and academic skills. The structure is made out of wood frames and enclosed by movable panels. All the interior furniture is movable, including the book carts, to give children agency on the configuration of the space. The facade towards the street is made of opaque acrylic panels thermoformed in the shape of bubbles, good to reduce outside noise. The lower ones serve as nap pods where children can rest and read.

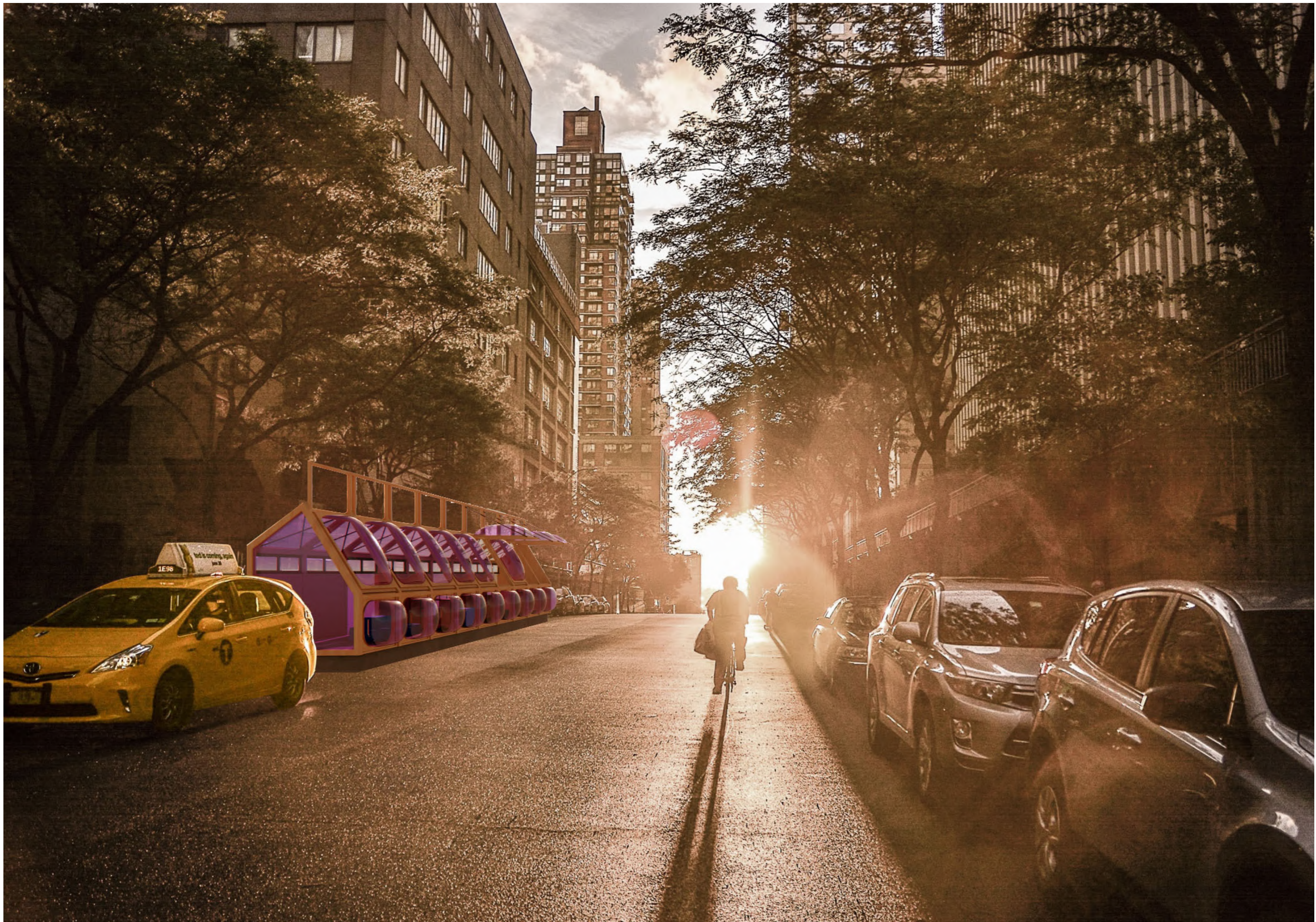

A book to change the world

Excerpts from an essay about “Seven American Utopias: The Architecture of Communitarian Socialism” by Dolores Hayden

Dolores Hayden’s work is crucial in advancing the academic discourse around feminism, and expanding the field of architecture to issues of landscape, urbanism and political organization. “Seven American Utopias: The Architecture of Communitarian Socialism” is Hayden’s first book, published in 1976 by the MIT press. Throughout the book, the author describes in almost scientific spirit seven communes that lived in alternative ways across different time periods in the United States. These groups of people distanced themselves from mainstream culture to challenge internalized paradigms of society. In the same way, Hayden’s aim with this book was to question certainties about the role of the architect and expand what was considered “architecture” by the 1970’s academia.

This book is an ideology machine urging architects to resist the notion of architecture detached from the process of building, and the figure of the architect as a hierarchical, commanding individual. It does so by looking at the relationships between community, organization, ideology, construction systems, etc. to explain the physical configuration of the settlements. This opposed the notion that architecture is the result of a master plan designed by one individual person, or a product of a genius single idea. Through this book, Hayden repositions the architect as an interdependent agent, seen as a

facilitator rather than as someone that aims to represent perfect societies through the purity of forms.

The idea of acknowledging architecture is influenced by things outside the field and the work of non-architects, was radical and would be highly influential for future movements. As such, this was an uncommon theme for an architectural academic book by an historian such as Hayden in the mid 1970’s.

Early postmodern theory was more interested in issues of architectural autonomy, where the aim was to develop a language of signs that would purely belong to architecture. These signs would have more to do with synthesizing historical buildings and their typologies, than representing local culture. This book, on the other hand, conveys the need to learn from local organizations and construction systems to have a more authentic and meaningful architecture.

After the social upheaval of 1968 around the world, and continuing through the first half of the 1970’s, it became clear that society was pushing for deep change. In architecture, this meant shifting the traditional sources of knowledge from academia to learn from the broad spectrum of actors involved in building, as well as from “bottom-up” developments. Dolores Hayden’s

book calls for a new architect, one that sees environmental design as an holistic approach to architecture, one that challenges the traditional American family lifestyle and the capitalist industries. The critique of the culture of consumerism in America is an underlying theme for the book, and a relevant topic at the time the book was written. The fast development of new electronic technologies was revolutionizing media and actively creating a new image of modernity, which included the mass consumption of small machines and gadgets for the body and the home.

A call for a new environmental architect

The ultimate promise Dolores Hayden is making with the text is that replacing “visionary designs” with “politically self-conscious building processes” ultimately has the power of changing society as a whole. And, according to the author, this will be achieved through environmental design. The text takes for granted that people agree environmentalism is the path architecture should follow. It does not spend any time introducing or arguing for environmental design. On the contrary, it says that it’s something that is already happening, in the same way as non-architects are building their settlements, but it has just been overlooked by

practitioner architects and academia.

The book does not try to convince the reader that environmental design is the thing that will bring about the desired change. It presents this idea as a fact, in the same way it talks about environmentalism as the new all-encompassing value for architecture.



For instance, in the introductory chapter of the book – called “Idealism and the American Environment” – Dolores Hayden explains that she will use “environmental design”, “physical planning” and “landscape architecture” in an interchangeable way. This loose definition is the only reference to environmental design in the introduction chapter, which seems an oddly brief mention to such a key concept for the book.

The book as a manifesto

The content of the book is separated in three parts: “Seeking Utopia”, “Building Utopia” and “Learning from Utopia”, in a seemingly organic sequence. Both the first and the second part analyze the communal settlements, while the last part presents a list of “lessons” taken from the case studies. This is, in format and in language, a manifesto for the new architect. It is a list of soft rules the author wants to reinforce as positive practices. These new best practices are compared to, either literally or in a less explicit way, to paradigms of the field. The lessons are:

1. Tentative designs representing ongoing collective processes may serve community needs better than finished designs which are the work of only one designer.

2. Individual, expressive involvement in construction, landscaping, decorating, and inventions complements collective design frameworks.

3. Communal territory is not created by taking away private territory.

4. Needs for private territory are not best served by private family houses.

5. Spaces which link communal and private territory must receive special attention.

6. Uniqueness may result from simplification and standardization, rather than complication and expense.

The role of the academic book

The role of an academic book is to disseminate research and academic discussion among the professionals within a discipline. Usually they are a long-form publication written by a scholar, and published by an academic or university press. Generally speaking, architecture historians who write academic books have always favored monuments, either buildings or men with grand personalities.

Dolores Hayden takes an opposite approach and gathers the names of people who recounted their experiences as settlers or visitors. She recognized them as sources of knowledge by thoroughly writing their names in the notes for each chapter and in the appendix section at the end of the book. Maybe the fact that Hayden worked on the extremely detailed scale of first and last names, collecting a database of members of each commune, is a way to defy the monumental scale of the past.

There could also be a debate about whether by doing so she is succeeding at putting non-architects in architecture history books or if she is actually monumentalizing their names and undermining the idea that “every man has a draft of a new community in their pocket”. A phrase originally by Waldo Emerson, used by Hayden to talk about one of the communities, Oneida. But, it can also explain the spirit of the times for Hayden in a broader sense: a moment that felt like anyone and everyone could bring about the desired change, without needing to be part of the traditional cultural elites. In the same way, the fact that the book allows for the settlements to be studied as models for alternative developments could also be seen as monumentalizing them.

Final thoughts

Seven American Utopias is a thorough recollection of models of communitarian living in the United States across two hundred years. The author makes an effort to describe in detail the ideologies, the political and administrative organizations, the processes of design and building, land ownership issues, access to transportation, relationship with natural resources, and how all these things define the physical configuration of the settlements.

From the start, Dolores Hayden positioned herself in one of the most prevailing questions of architecture history: is architecture the idea of a building or the building itself? She supports the latter, architecture being the building, which implies that there is a construction process, a context, a program, and an organization that has to be acknowledged. In this sense, in her view, architecture is not just about the built object, but about everything that is around life and culture.

The ultimate goal of the book is to make available new modes of life, with the aim that even if the communities ultimately fail to remain cohesive and sustainable, their core ideas would still inspire others to question the status quo and try something different. In this sense, Hayden’s

selection of study cases for the book is based on the idea that a successful community are those whose practices that remain provocative even after the community itself has disbanded.

“Seven American Utopias” is an ideology machine in the sense that calls for a new environmental architect as a generator of societal change. It urges architects to stop focusing on designing finished products, to start looking at processes. It conveys the message that getting rid of the traditional “authoritarian” architect is the first step necessary to allow other people to engage with construction, to ultimately be changed by being part of that process. This comes at a time of revolution, where people were already experimenting with self-building, co-living and other modes of critical environmental practices.

The manifesto part of the book can be understood as a compilation of ways in which building processes can be – and must be – used to express ideology and define territory. These rules are intended as a manual for the new environmentalist architect. The “lessons from utopia” are situated, as the settlements themselves, in the thin line between being too utopic to be replicated or being too adjusted to problems of reality to still carry the seed of revolution.

“Seven American Utopias” is a product of academia that was still seeking validation from academia at the time it was published. Hayden is trying to persuade academia of the idea that the relationships between modes of living and space was, in fact, architecture. In this task, the book is supported by the acceptance from a general field of practitioners, particularly people who were already concerned with environmental issues, as it was starting to be common in the mid 1970’s. The book “fits in” with the spirit of the time by calling for change, and therefore is successful at becoming a relevant voice within the academic field.

Finally, the use of images of reality and utopia, and the avoidance of comparison with contemporary modes of living, is an effective way of maintaining the case studies in the delicate line between utopia and reality. Presenting the settlements as replicable models but also not so adjusted to reality that still can carry a seed of revolution.

Bibliography

Celant, Germano, and Cindi Strauss. *Radical: Italian design 1965-1985 : the Dennis Freedman collection*. New Haven: Yale University Press. 2020.

Hayden, Dolores. 1976. *Seven American utopias: the architecture of communitarian socialism, 1790-1975*. Cambridge, Mass. : MIT Press, 1976.

Hayden, Dolores. *Redesigning the American dream: the future of housing, work, and family life*. New York: W.W. Norton. 2002.

Jencks, Charles. *The language of post-modern architecture*. London: Academy Editions. 1991.

Kapur, Akash. *The return of the utopians, What today’s movements for social and economic reform can learn from the intentional communities of the nineteenth century*. The New Yorker. 2016.

Tafuri, Manfredo, and Barbara Luigia La Penta. *Architecture and utopia: design and capitalist development*. Cambridge, Mass: MIT Press. 1976.

Aldo Rossi goes to trial

As part of the history seminar “Architecture: The Contemporary” we were asked to bring a building to trial. We accused the Scuola Elementare in Fagnano Olona, of Aldo Rossi, of a set of crimes, to which the building, acting as its own defense attorney, argued against based on Rossi’s theories.

The following script was written and performed in collaboration with Rocio Crosetto, Shulong Ren and Yifei Yuan.

Part 1: Introduction

PROSECUTOR: The Scuola Elementare at Fagnano Olona, a building designed by Aldo Rossi in 1972, is called to TRIAL.



This building has been accused of a series of terrible crimes that we will proceed to announce to you, dear members of the jury. But before starting this session. Let the building present itself.

BUILDING: Hello everyone. As you already know, I’m the Scuola Elementare at Fagnano Olona. Honestly, I have been feeling very comfortable with myself lately. Very confident. I believe it is probably because of this sort of ongoing Rossi’s neo-revival we are experiencing these days. I feel I am back in fashion. But well, all great until I got accused of some crimes. So here I am.

Let me tell you my story: I am one of Rossi’s first buildings. When he designed me, he had already written The Architecture of the City. However,



it didn’t have an English translation until much later so you probably wouldn’t know it yet.

So...I was designed in 1972 and I am located in a small town 40 km north of Milan. Rossi wanted me to be like a small city. You can definitely see that if you look closely enough. The city, you may know, is built collectively by the continuous superposition of layers across history. We all share a collective memory of the city so that we recognize it, in spite of it having different forms across the world.

I will explain myself in more detail. I am the square in the center of my plan, and the monument that is inside of it: a round volume which is the library of the school.

I am the theatre formed by the monumental stairs and the empty space of the courtyard. I am also the classrooms, which are like houses of a city, distributed in wings according to a central axis of symmetry. And of course, as this place used to be occupied by a factory before my construction. I also am some elements that refer to the past of this place. Like a chimney aligned to the entrance.

Essentially, I am like the city because I am all these things juxtaposed. I am past and present

perceived all at once. A whole, not the sum of my parts.

PROSECUTOR: That’s enough building, they get it...don’t try to buy the jury before we even start. You will have more time later to speak for yourself. I will proceed to read the crimes you are suspected of committing. You are accused of:

1. Representing an obsolete past that we are leaving behind.
2. Your timeless abstract form is incapable of parts.
3. Prioritizing the form of the building rather than its function.
4. Not aiming for the maximum efficiency and flexibility.

Let’s begin the trial.

Part 2: Does not represent the future

PROSECUTOR: You are accused of representing an obsolete past that we are leaving behind. We want our buildings to be about tomorrow, or at least, a snapshot of the best version of today. The value of architecture is its capacity to renew our hopes for the future. On the contrary, you represent an image of the past, even at the time

you were built. We have proof.

We bring Mario Bellini to testify. He was the curator of the 1972 exhibition “Italy: The new domestic landscape” at MOMA.

MARIO BELLINI: Thanks for having me. This is a picture of the exhibition I curated at MOMA the same year you were designed. New technologies were being used to solve the problems of everyday life. Moreover, the presence of designed artifacts in every aspect of life was so successful that “good design” became just “design”. You, on the other hand, completely negate these technological advancements. The only artifact you display is a clock on the wall at the end of the staircase. And it’s not even a digital one, a technology that was around since the 50’s.



The second image is a collage called Happy Island by Superstudio. Around the same time you were designed, the forward-thinking group Superstudio was representing futuristic ideas about the built environment. This image represents the world as a continuous landscape made of hidden technological infrastructures that would support a nomadic lifestyle for people. Great stuff. Instead, the drawings of Aldo Rossi reference only architecture elements and composition. Nothing that would give us a sense or vision of the future.

PROSECUTOR: Well said. Lastly, your plan resembles more of an 18th century hospital than an elementary school in Fagnano Olona. You don’t carry any novelty, nor experimental inquiry, which ultimately leaves no chance for people



to do things differently, to evolve, to become their future selves...

BUILDING: You have it all wrong. I will ask the architect himself, Aldo Rossi, to respond to these claims.

ALDO ROSSI: Architecture has nothing to do with technological artifacts, or images of the future. I don’t care for the over-optimist illusion of the future that is just creating images of an Eden of labor. I want to reveal the power hidden in the architecture, which lies in its essence, or what I like to call its type.

The type is what is permanent, constant. It is the essential collective memory from which architecture takes meaning. It is a logical principle that is prior to form and that constitutes it.



Fagnano Olona’s type is the city itself, therefore it cannot be, as you say, an image of the past. The history of the city is what constitutes its present, what gives meaning to its present form. It doesn’t make sense to say that a city is “an image of the past” as long as it has the possibility of being re-purposed.

This collective construction over time IS the city. By referencing history and repurposing it in the Fagnano Olona school I am not “supporting an image of the past”, but being true to the principles that form the city. This makes my architecture prevail. Or, in your terms, be part of the future.

BUILDING: So, what Rossi is saying here is that I’m innocent of being an image of the past because I’m actually timeless. If that doesn’t



renew your hopes for the future honestly I don't know what would.

Part 3: *Timeless (or incapable of representing its particular time and place)*

PROSECUTOR: Being timeless requires a certain degree of abstraction, which brings us to your second crime. You are accused of being "too abstract". In other words, of not being specific of a particular time and place. We expect buildings to represent the spirit of the time since they are, after all, a catalogue of human progress. We are bringing our expert, Manfredo Tafuri to present the case for this one.

MANFREDO TAFURI: Hello everybody. Hello



building. I will amplify the prosecutor's claims. So, what is the crime in being "too abstract"? The problem of placing your value in the abstract concept of a type is that it is only true if everyone can relate to the same original concepts. And that is a very naive belief.

How can you expect people from Olona to have the same mental references to someone in, for instance, Rome?. Or, even, how can we expect people from this very jury to have the same mental references with each other? Architecture should relate to real places with real people having real experiences.

Lets see some picture evidence. You don't look like either Fagnano Olona city or Rome. You look like a diluted image of a city that does not exist.



You resemble more of a Chirrico painting of an idealized Italian city square than the overlapped layers of history that you claim to be.

PROSECUTOR: Thanks Manfredo. Seems like you, Building, are intentionally detaching yourself from the context. Your materials don't speak of the site. In the same way your plan, as we saw before, is more reminiscent of an 18th century hospital than what we might find at a mid sized town in the north of Italy. In that sense, you appear without context in all these representations, in which it is also evident that scale acts in favor of abstraction rather than to appeal to the human experience. Symptomatically, your sections don't have any human figures.

BUILDING: So you are accusing me of being too abstract to the point of being unrelated to a time and a place, and disconnected from the real city. I would say, that is not a crime.

I am like a monument. I carry the collective memory of a place throughout time. The concept of locus is important to understand this. This is the relationship between a certain specific location and the buildings that are in it. It is at once singular and universal, a never-ending relationship that generates the city. I might be abstract in form and essence, but I am

permanently making the city around me inasmuch as the city it is making me. Being abstract does not limit me from engaging with the city. I can be repurposed to respond to the city's current needs, whatever they are in any period of time.

Part 4: *Form does not follows function*

PROSECUTOR: I'm not convinced, but this takes us to your third crime. Rossi has always favored form rather than function. You do not look like a school. You are not constructing the image of what a school should be like. In other words, form is not following function. This is a serious crime. You could be anything. People expect things to look like what they are. You are getting people confused!

BUILDING: But which is the form of a school? Is there one? Should every function have a particular form? Is that a LAW? I can speak for Rossi in this matter, we have discussed this a lot. Rossi completely rejects the idea that form follows function, which was Sullivan's popular claim. Rossi is interested in permanence, and function is not a permanent matter. It changes over time. I want to bring back to the judgment stand the Palazzo della Ragione in Padua. It first hosted the law courts of the city and now houses an active

retail market in the ground level. And it looks like neither.

Architecture is much more complex than temporal functions. Rossi is interested in the type, which represents the essence of architecture. As I mentioned before, he says: The concept of the type is permanent and complex. It is a logical principle that is prior to form and that constitutes it. Function changes over time. On the contrary, the form remains.

Please, I would like to invite Pier Vittorio Aurelli to comment on this matter. He will better relate Rossi's architecture with the idea of an autonomous theory and the political implications it has. Pier...



PIER VITTORIO: Yeah, thanks Building. I was about to jump in. In my work *The project of Autonomy*, I claim that Rossi's work is to establish a new socialist theory of the city opposing to the city of bourgeoisie. Rossi believes that the hybrid and technological heteronomous city is caused by neo-capitalism.

Due to the rapid development of technology, in order to integrate social resources and workforce, a new urbanism arose, which was characterized by integration of urban and rural area, mega-structures, and the establishment of the overall framework of the new city. Rossi was against integration, technology and overall planning. He decided to learn from history, from the discipline of architecture itself, so called architectural autonomy.



He also admired the individuality of urban artifacts, or as he called it the singularity of Locus. The typology and the Locus concept, as well as Rossi's rejection of functionalism, is his way of rejecting capitalism.

Part 5: It is not flexible. It is not efficient!

PROSECUTOR: Well, but our present time demands us to be efficient, to be productive, to be flexible, to be specific; to be all those things right now. For buildings society demands exactly the same. The Scoula is accused of the fourth and last crime: Its lack of efficiency and flexibility.

Rossi rejects completely the Modern Movement triumph in the liberation of the 18th and 19th

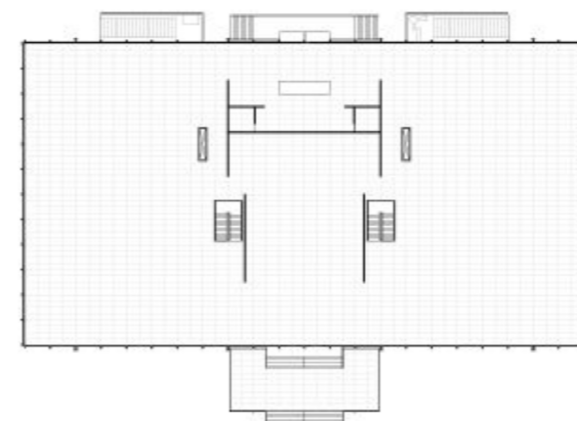

century Beaux Arts plan corset. How could he design a school with a miniature palazzo-like plan? After Mies' Crown Hall??. Rossi rejects the free-plan, which has been probably the most radical conquest of the Modern Movement. The free-plan allows experimentation, evolution, and change to happen. In contrast, Rossi's architecture is a grammar of rigid geometric volumes that lacks flexibility. His architecture is not efficient in responding to today's needs.

BUILDING: Wait, wait, wait. Are you really accusing me of not being flexible and efficient? I can easily adapt to other functions. Everything that has prevailed in history did so because it was capable of absorbing new functions. For instance, my simple forms: a central void, a cylindrical room, and a series of small and medium clus-

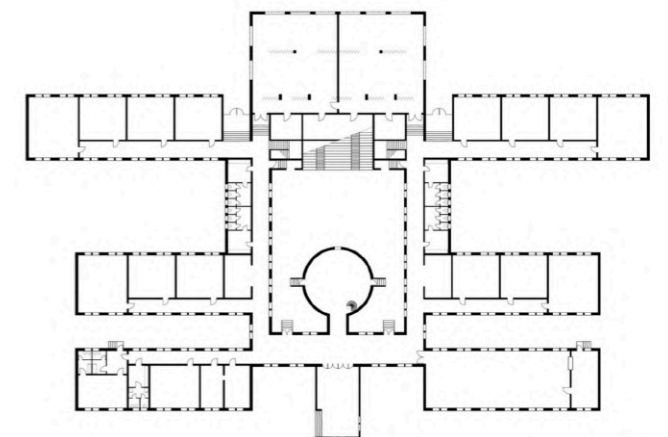

ters can host many functions. This architecture is highly flexible in terms of having a variety of spaces. And I don't need the latest technology to do that. I didn't need luxurious construction materials, high-tech products, complex geometries or specialized workers to be built. Tell me if that is not efficient. Less is Enough, as Pier Vittorio would say. I am austere by choice. By political choice actually.

Just think about it one second: the customization of things actually makes them much more rigid. Specificity is inherently linked with rigidity. If something changes, your product becomes obsolete. Part of Rossi's idea of autonomous architecture was detaching form from function so that nothing is so specific that it couldn't be anything else. Therefore, when things change, there is no real need for building anew, you can re-purpose the old buildings. In this sense Rossi's architecture opposes the consumerism culture of neoliberalism. My austere look just reinforces his political stances.

Part 6: Closing statement

As a conclusion of this trial we believe that the crimes that the Scuola is accused of can be understood in very different ways. We believe

that the architectural concepts that each of us defend represents what we think and what we are. Architecture, to a certain extent, is an image of the architect, and the ideas that we embrace. We might also find ourselves agreeing to contradictory statements and realizing some of the complexities of architecture itself.

Images

1. Perspective for Scuola elementare a Fagnano Olona, Italy. Drawing by Aldo Rossi.
2. The school's central courtyard with the cylindrical library on the center.
3. New home appliances exhibit at the 1972 MOMA exhibition "Italy: the new domestic landscape".
4. "Happy Island" collage by Superstudio
5. Piazza di Spagna, Roma.
6. Staircase in the school's central courtyard.
7. View from one of the sides of the project featuring the pre-existing chimney that was kept in place
8. Piazza d'Italia con Ariadne, 1948. Painting by Giorgio di Chirico
9. Monumento ai Partigiani at Segrate, Aldo Rossi, 1965.
10. Palazzo della Ragione, Padua c. 1890.
11. Crown Hall plan, Mies Van der Rohe, 1956.
12. Fagnano Olona school's plan, Aldo Rossi, 1972.

Bibliography

Rossi, Aldo. Introduction and Chapter 1 of *The Architecture of the City* (Cambridge, Mass: MIT Press, 1982).

Rossi, Aldo. "An Analogical Architecture," trans. David Stewart, *Architecture and Urbanism* 56 (May 1976): 74-6.

Vidler, Anthony. "The Third Typology" (1978). (reprinted in *Architecture Theory since 1968*)

Colquhoun, Alan. "Typology and Design Method," in *Essays in Architectural Criticism: Modern Architecture and Historical Change* (Cambridge, MA: MIT Press, 1981): 43-50.

Moneo, Rafael. "On Typology," *Oppositions* 13 (Summer 1978): 23-45.

Vidler, Anthony. "Renaissance Modernism: Manfredo Tafuri," in *Histories of the Immediate Present*. Cambridge, MA: MIT Press, 2008.

Argan, Giulio Carlo. "On the Typology of Architecture." Trans. Joseph Rykwert. *Architectural Design* (December 1963), p. 565.

McLeod, Mary. "Aldo Rossi, The Architecture of the City." *Design Book Review*, 3 (Fall 1983), pp. 49-55.

Aureli, Pier Vittorio. "Rossi: The Concept of the Locus as a Political Category of the City," in *The Project of Autonomy: Politics and Architecture within and against Capitalism*. New York: Princeton Architectural Press, 2008.

Tafuri, Manfredo. "The 'Case' of Aldo Rossi," in *History of Italian Architecture*, trans. Jessica Levine. Cambridge, MA: MIT Press, 1989.

The Gen-Z manifesto

How to read it:

40%

of students agree with the statement:

Buildings should present, or at least suggest, an image of the future

The trial of the Scuola Elementare Fagnano Olona (Aldo Rossi, 1972), offered an amazing opportunity to survey students of the seminar “Architecture: The contemporary” about what they believe architecture is, or should be. This survey was developed based on the arguments used for the Aldo Rossi’s trial, but expanded to refer to architecture in general. The eighteen statements refer to ancient architectural debates as much as current concerns. Our hope was that being confronted with such categorical statements would reveal something of ourselves. This exercise also gave us a sense of the climate of ideas of which we are part of, as a collective of students of a generation.

90%	The city is a collective construction layered over time
85%	Collective memory is not universal, but based on our personal experiences and places
70%	Buildings could be seen as a catalogue of human progress
60%	A building has the potential to ultimately generate a city
	Urban planning does not respond to the needs of the city but is often deliberate and driven by capitalist interest
55%	The value of architecture is in its capacity to renew our hopes for the future
40%	Building should present, or at least suggest, an image of the future
35%	The value of architecture relies on the principles that have prevailed across human civilizations
	Architecture should represent a particular time and place
	There is such thing as timeless architecture
30%	Customization creates the need for consuming more things
	The value of architecture relies on its essence, not in how it operates
	There is such thing as architecture that is “too abstract”
	There is such thing as an “essence of architecture”
20%	Buildings should be as efficient as possible
15%	Form should follow function
	The free-plan is the most flexible plan there can be
5%	We all share the same collective memory as human beings

