

PORTFOLIO
SUNGHYUN KIM

COLUMBIA UNIVERSITY
GRADUATE SCHOOL OF ARCHITECTURE, PLANNING AND PRESERVATION



NEXT EMERGENCY THINK TANK

Think Tank in Los Angeles

Advanced Architecture Studio VI, Spring 2022

Instructor : Galia Solomonoff

Collaborator : Kurt Cheang, Hannah Rose Stollery

To make things understandable, we have segmented knowledge into professions, departments, ministries, parties, regions, countries, disciplines, genders. We then compartmentalized information, allocated resources, and grouped people based on those fragments. And in the process of understanding one thing, one organ, one problem, we lost track of the whole, the whole body, the whole city, the whole country, the whole planet.

But the world and most things in it are interconnected. And Covid made it most clear. We now understand how things are related, connected, part of the same whole, where when one thing comes out of balance in one part, it destabilizes something else that seemed remote or not connected. The world is fluid and interdependent, markets like rivers flow and affect one another.

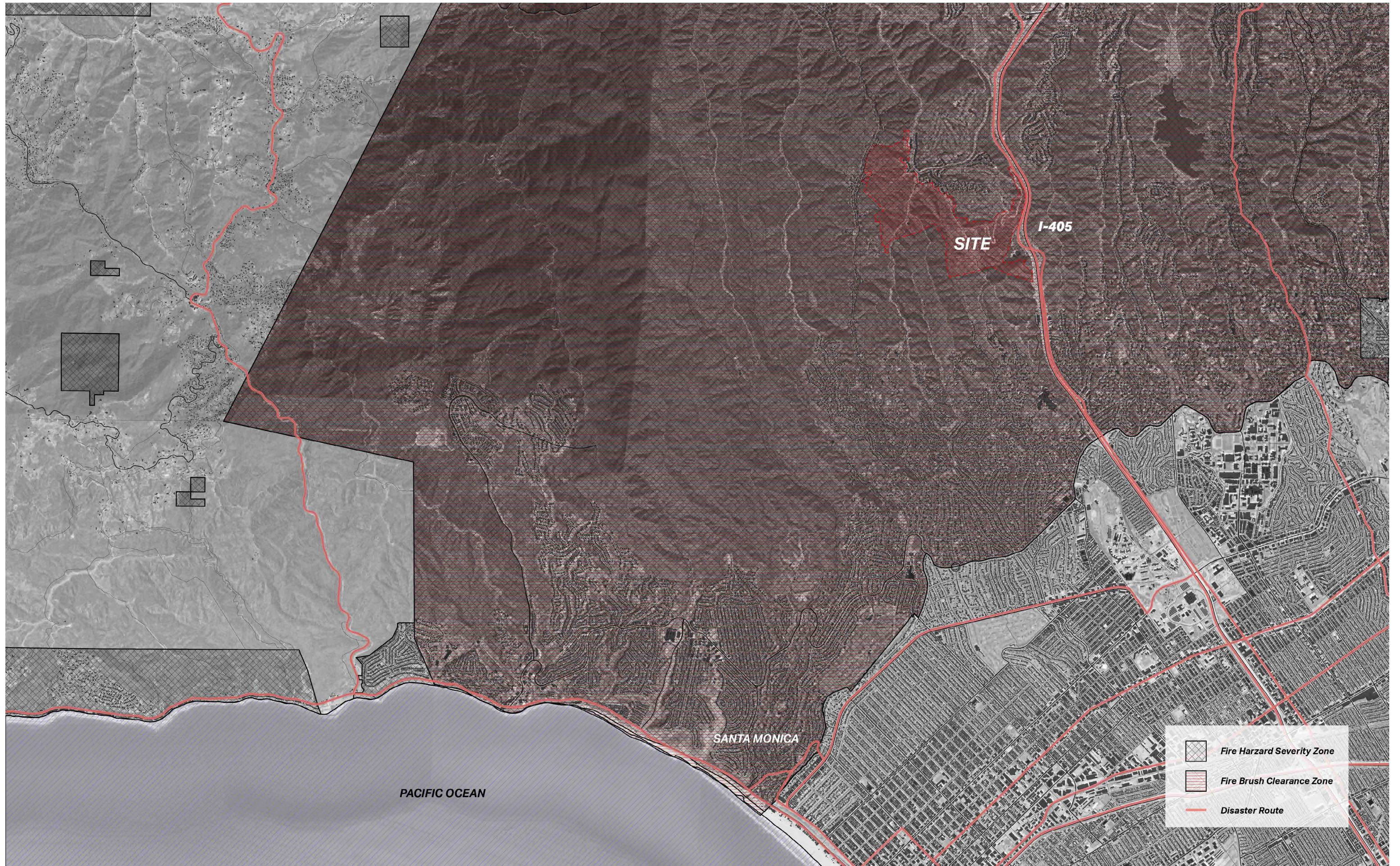

SITE

I-405

SANTA MONICA

PACIFIC OCEAN

	Fire Harzard Severity Zone
	Fire Brush Clearance Zone
	Disaster Route

MASTER PLAN

The building is built along the ridge of the mountain and is embedded in the rock. Rather than a typical campus with many separated buildings, our design utilizes the strategy of one continuous roof that is supported by 3 primary nodes, the auditorium node, main institute node and housing node. The bridging between the nodes acts as energy collection/ resource generation areas for solar, water and food, but it also creates a free flowing circulation between levels of the site and buildings through bridging.



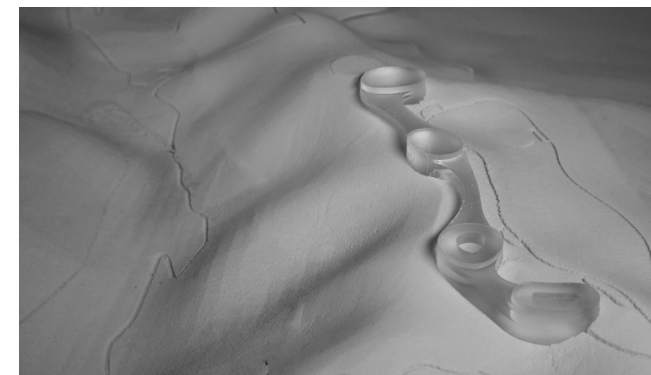
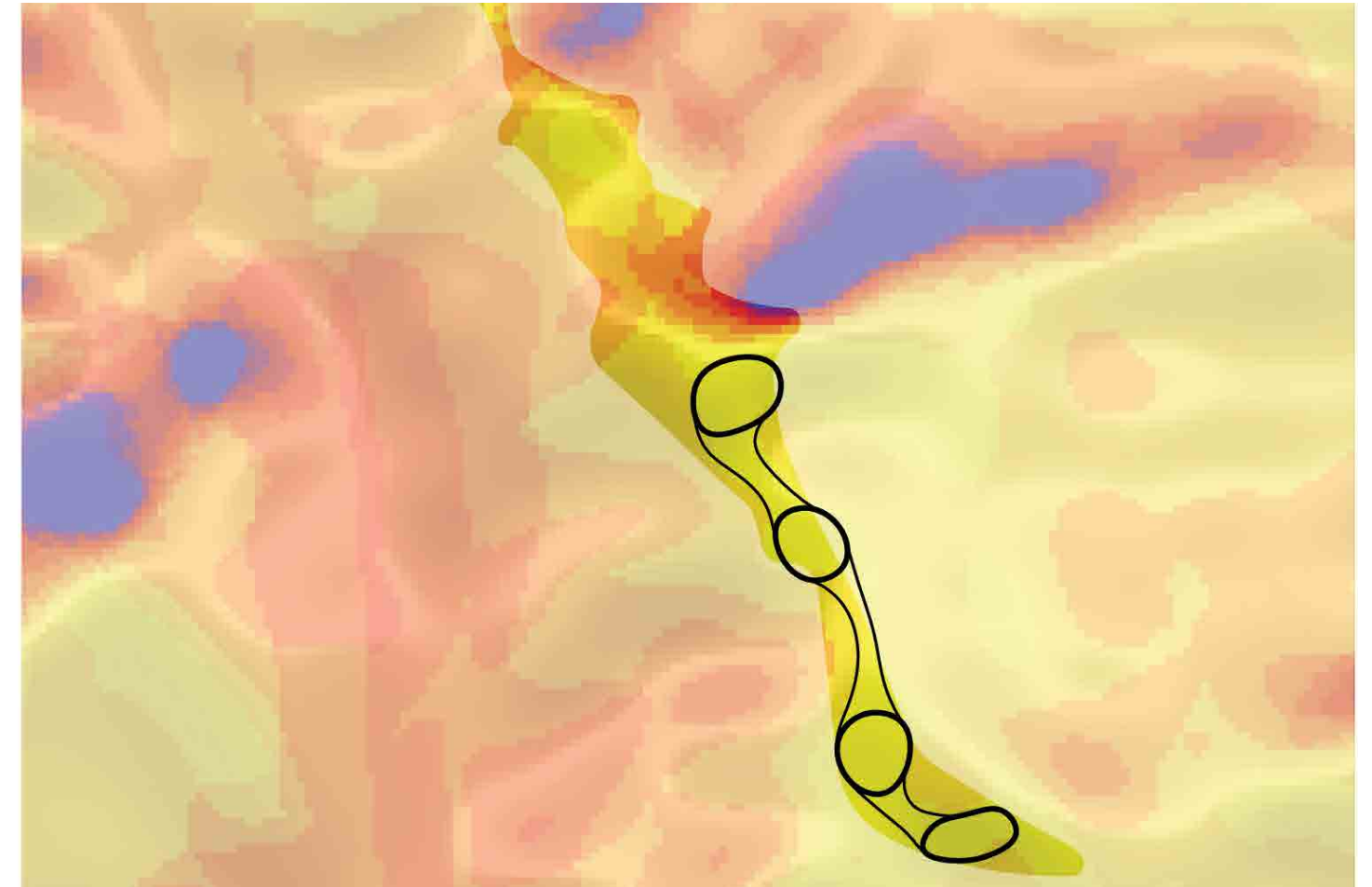

Shape from Solar Analysis

We analyzed the solar maps at the site and found 4 zones of the highest solar gain along the ridge, allowing for the building to be fully self-sustained and off grid, which is a crucial part to our think tank design and how we arrived at the general massing of our design.

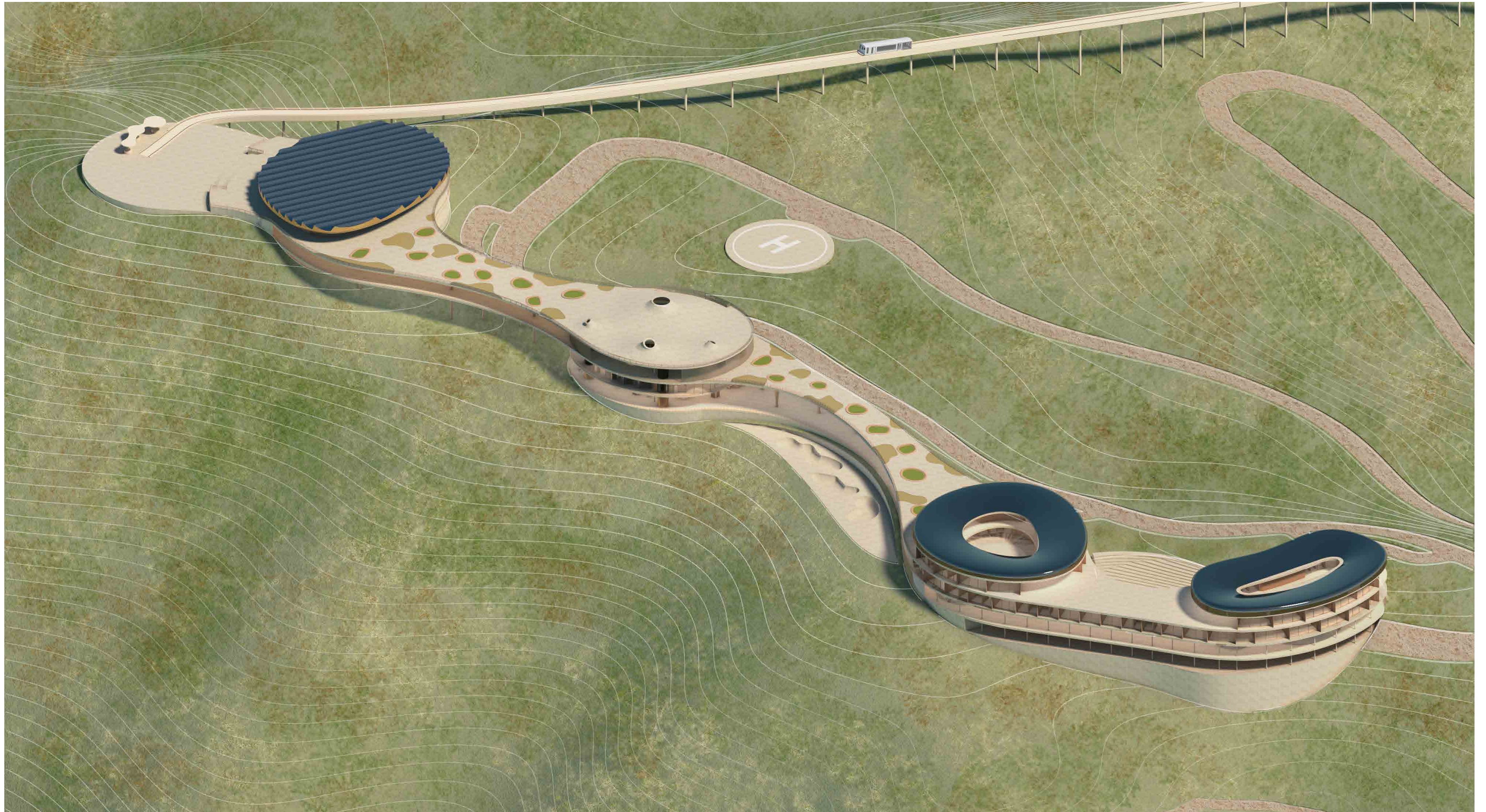

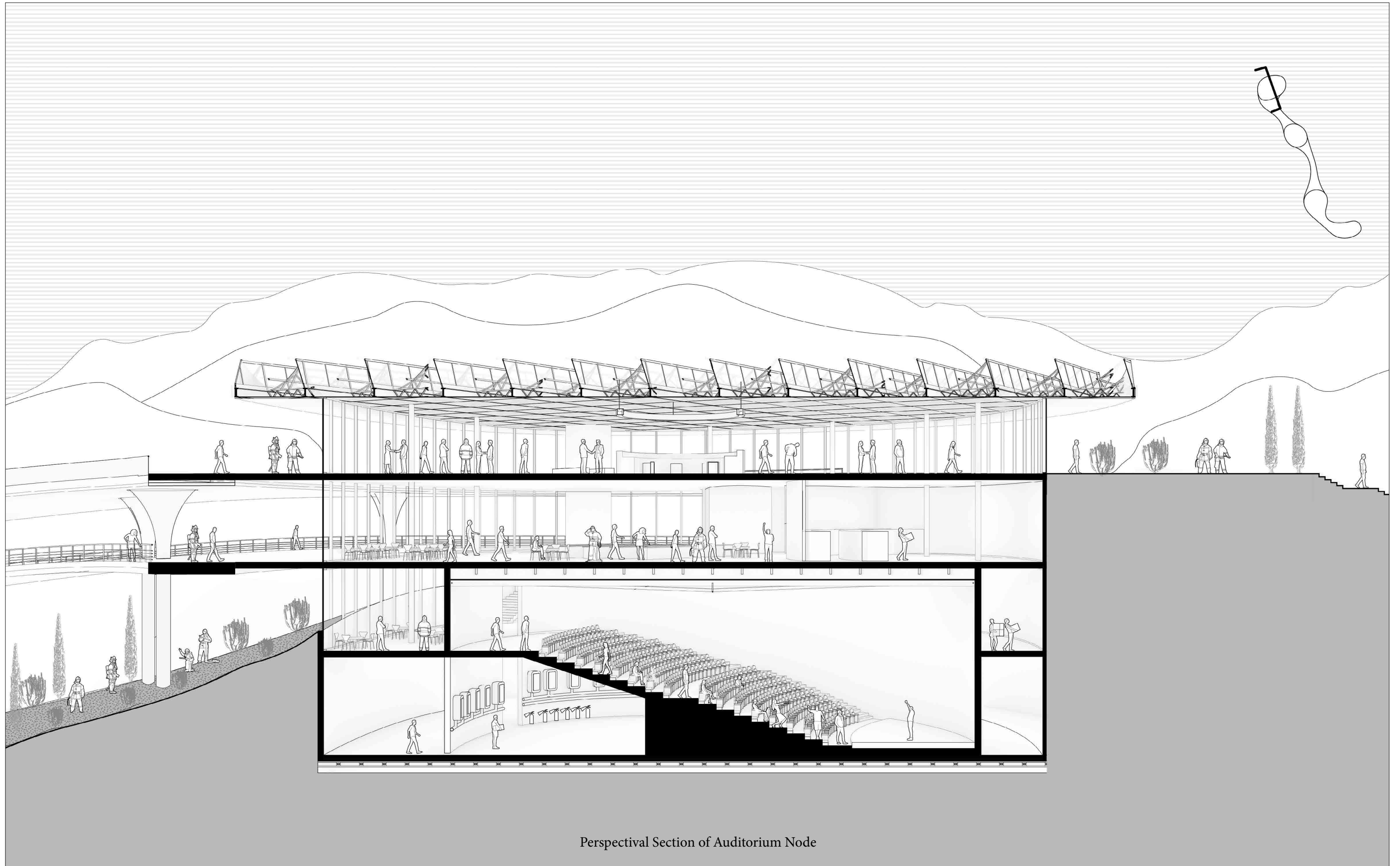

Perspectival Section of Auditorium Node

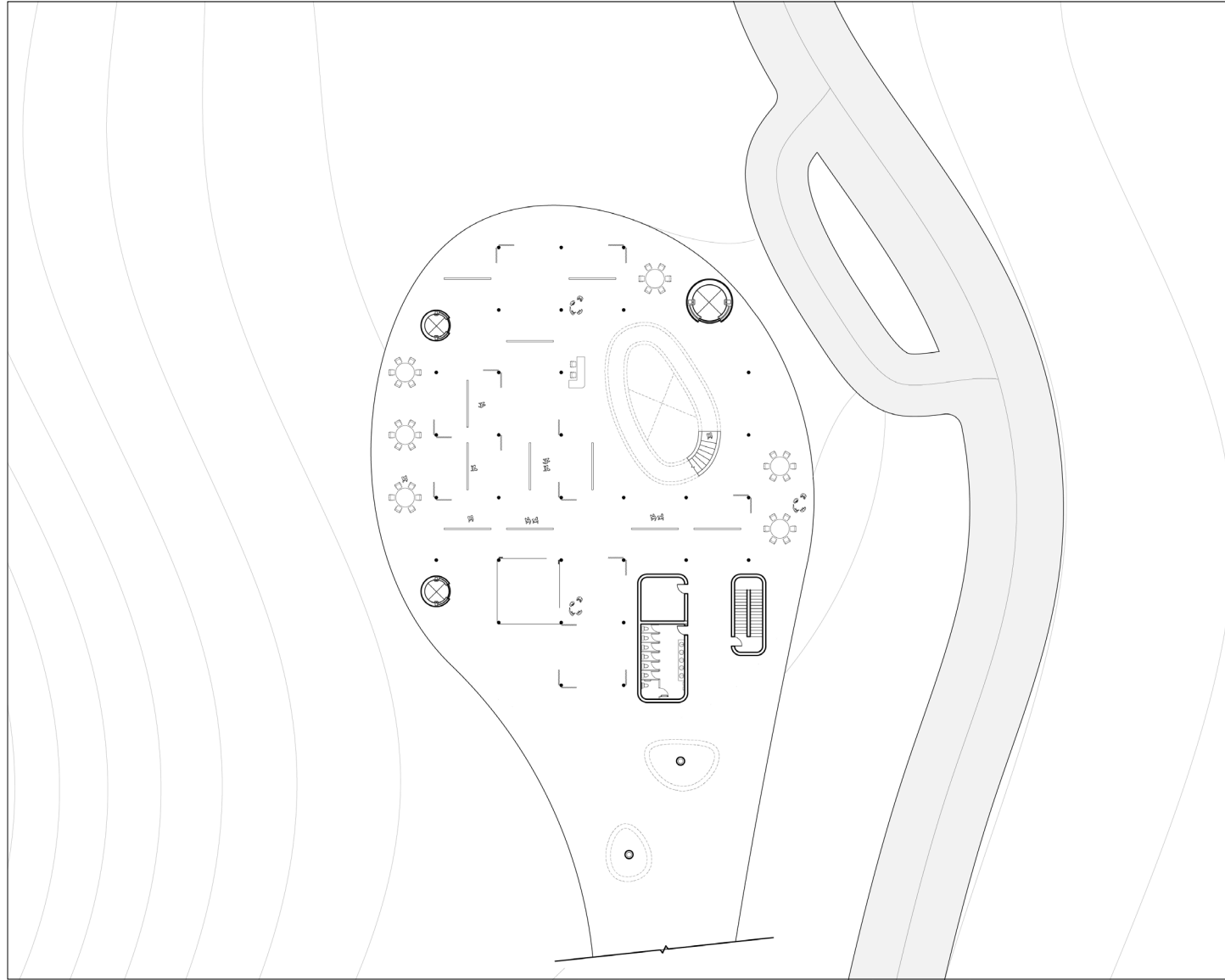

Non-Emergency | Temporary Exhibition Space

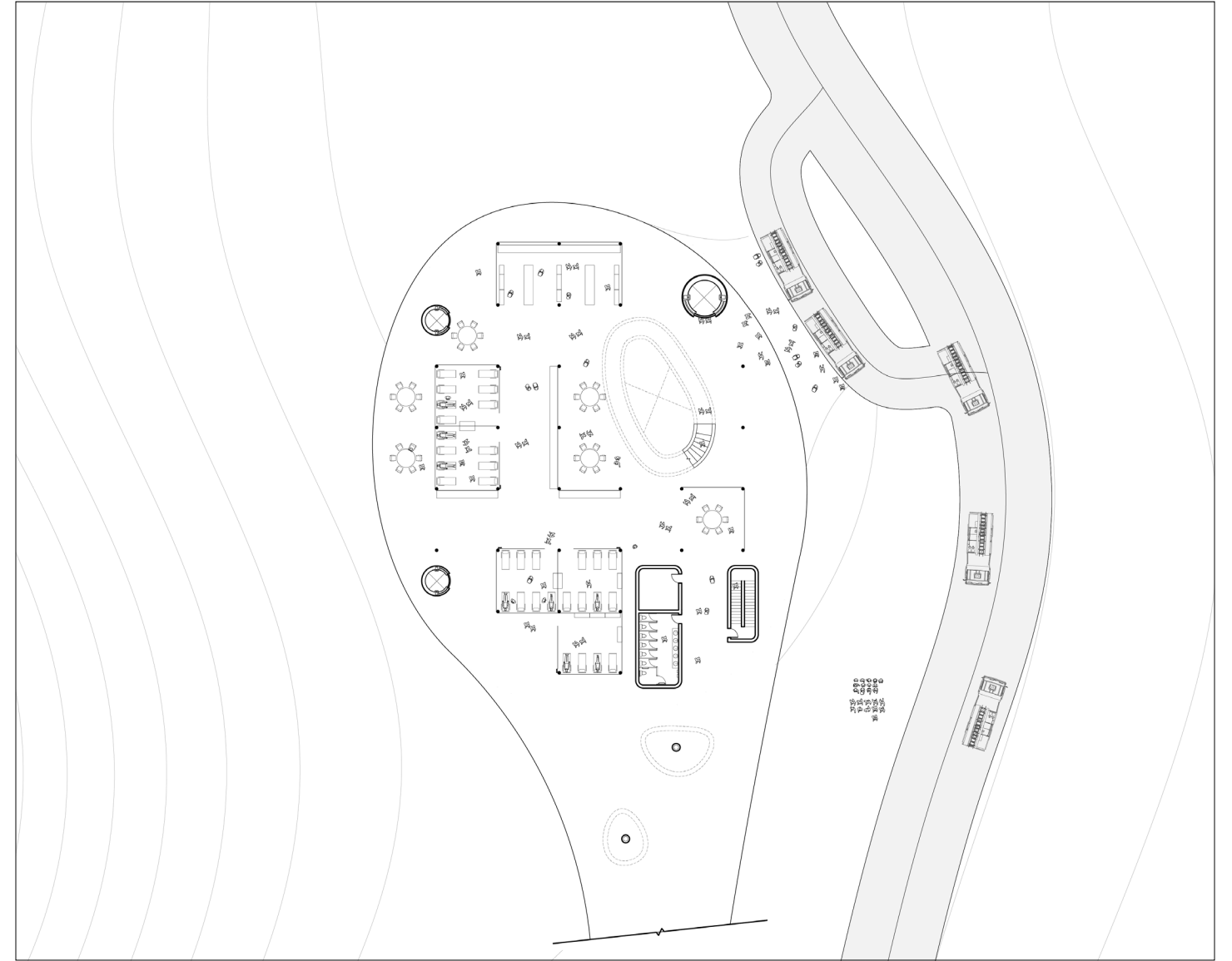

Emergency | Nursing and Rehabilitation Room



Non-Emergency | Temporary Exhibition Space



Emergency | Nursing and Rehabilitation Room

Main Institute Node is a flexible space that allows for adaptation for emergencies. During non-emergency, the space can be used for gallery and exhibition space for artists, but also photographers to display their work, capturing the dangerous effects around the world of climate change and natural disasters. During a disaster, the space can be converted into smaller rooms using accordion walls that expand to quickly form temporary partitions, allowing for privacy for emergency beds, nursing stations, water stations, rehabilitation rooms.

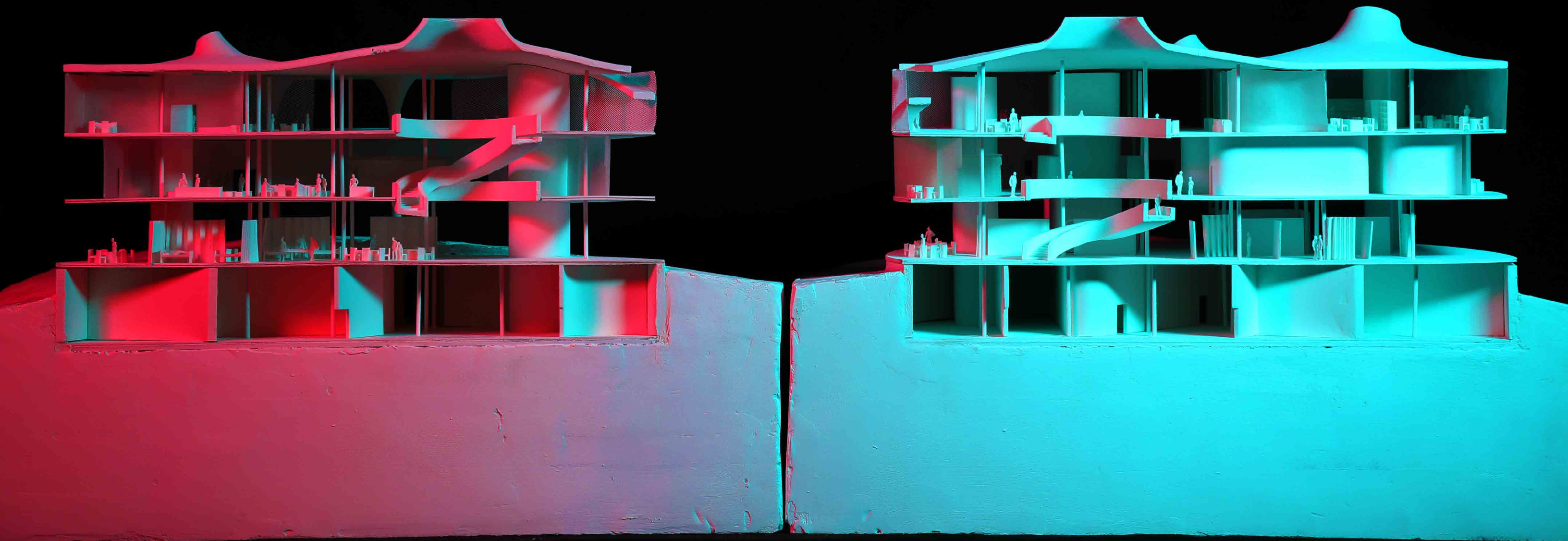

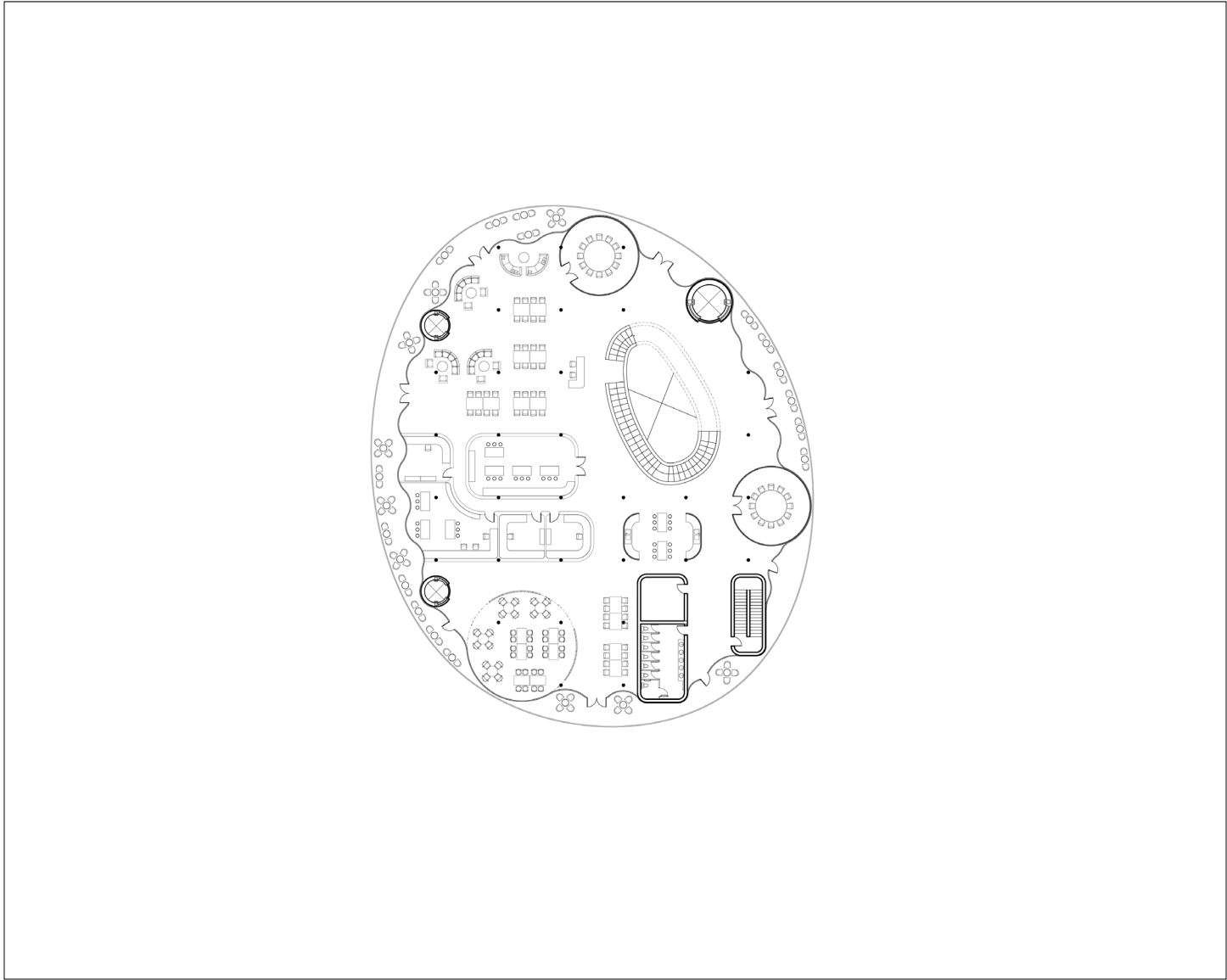

2nd Floor Plan | Main Institute Node

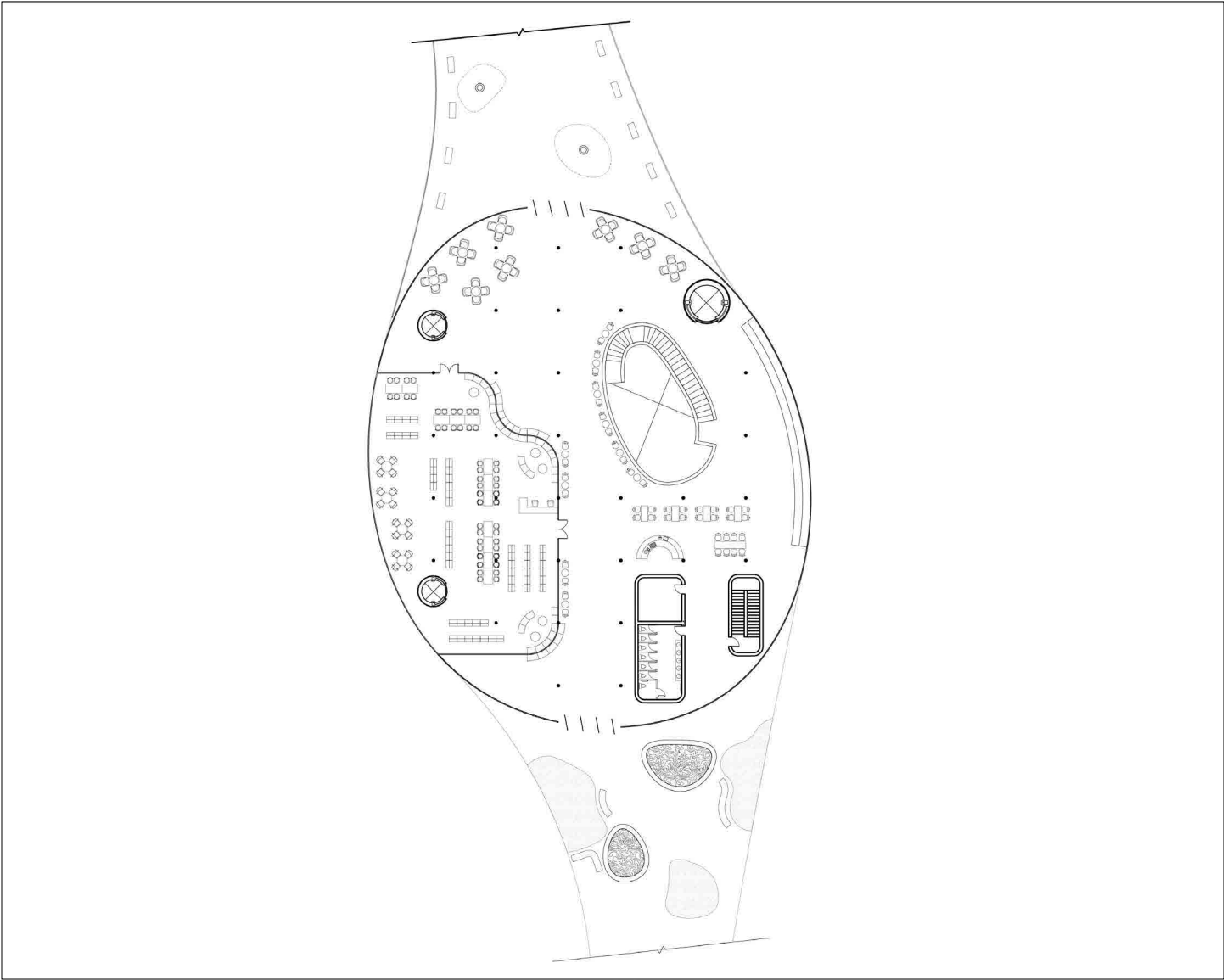

3rd Floor Plan | Main Institute Node





1st Floor Plan | Housing Node

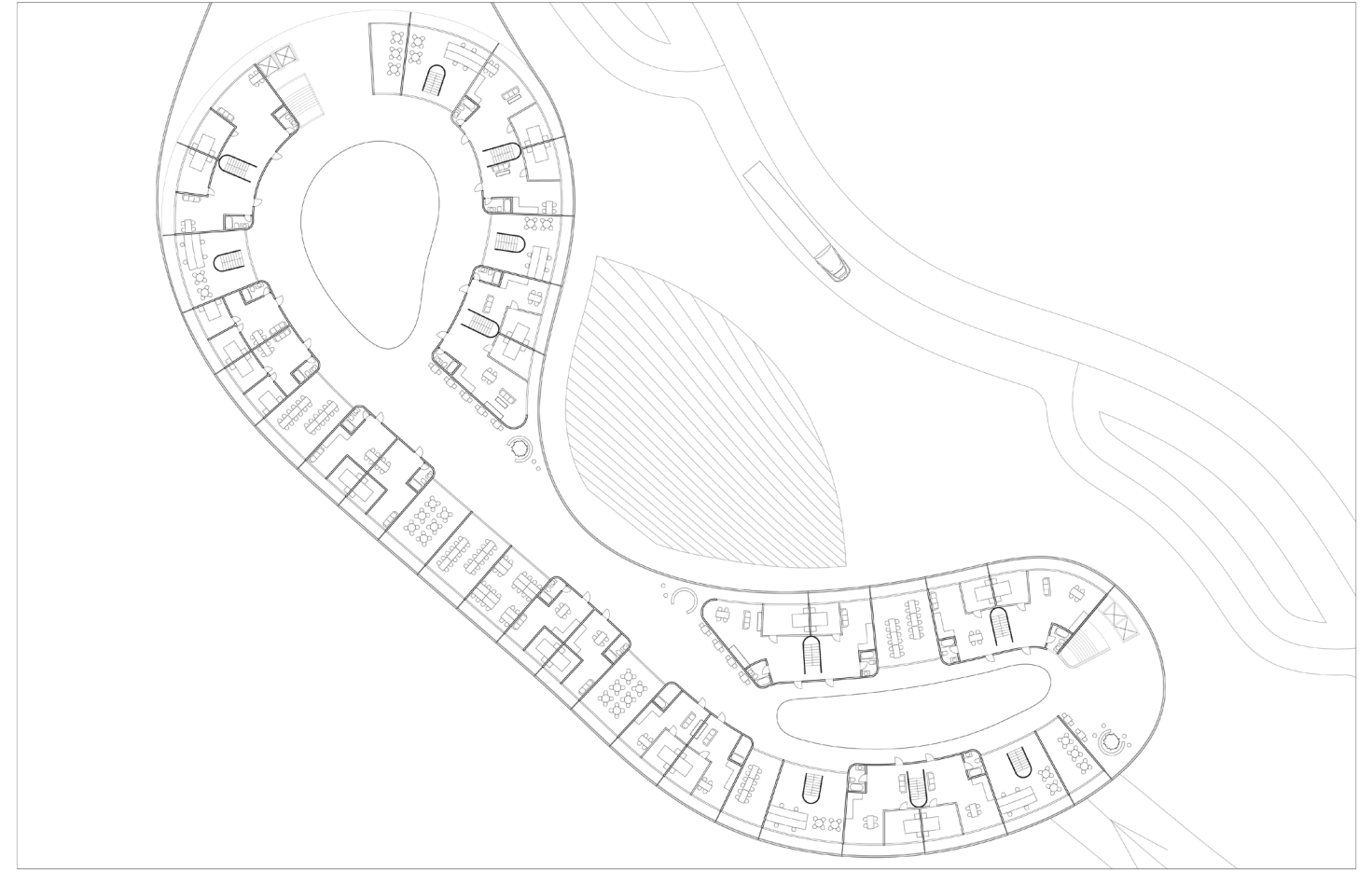

4th Floor Plan | Housing Node

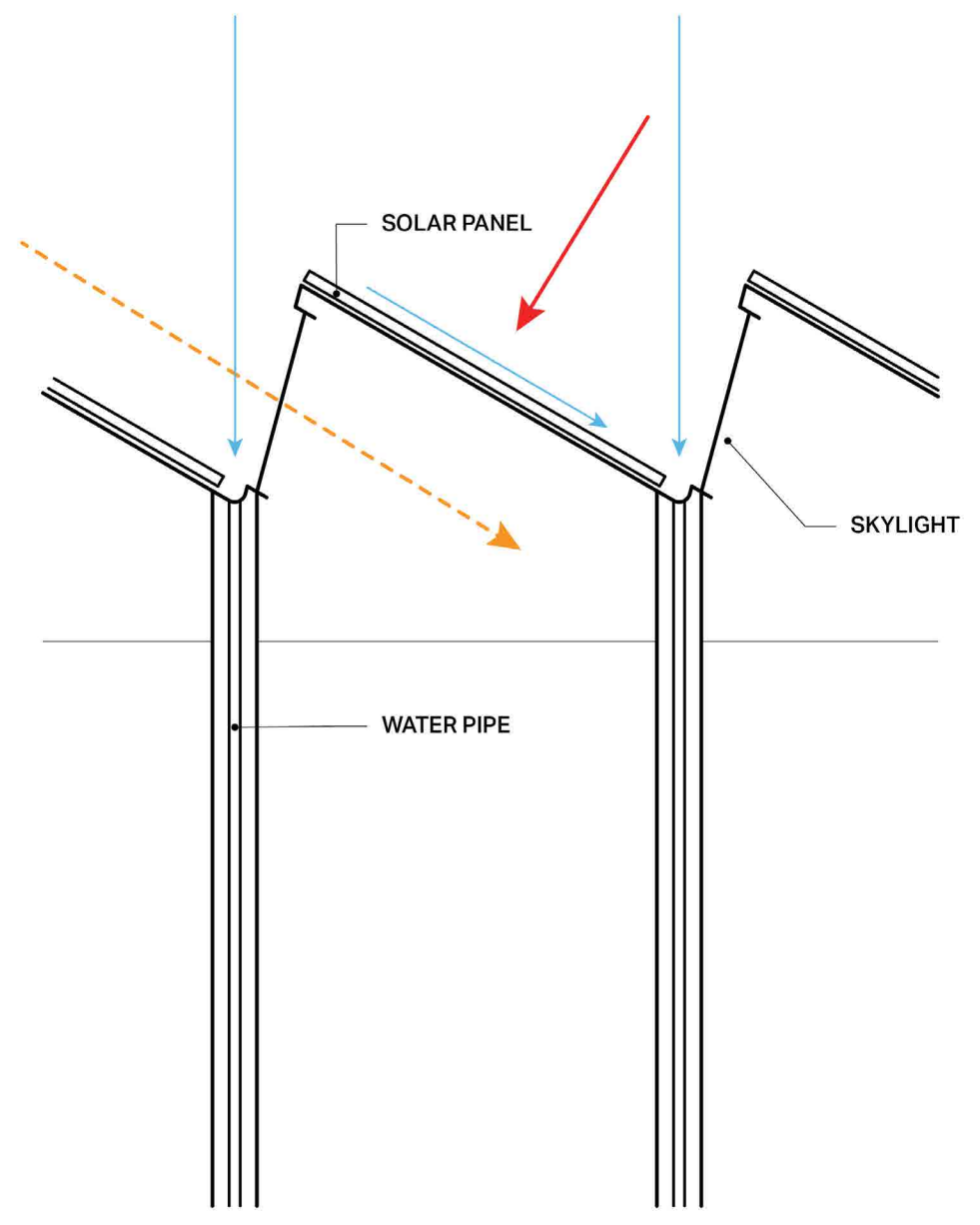

Auditorium Roof

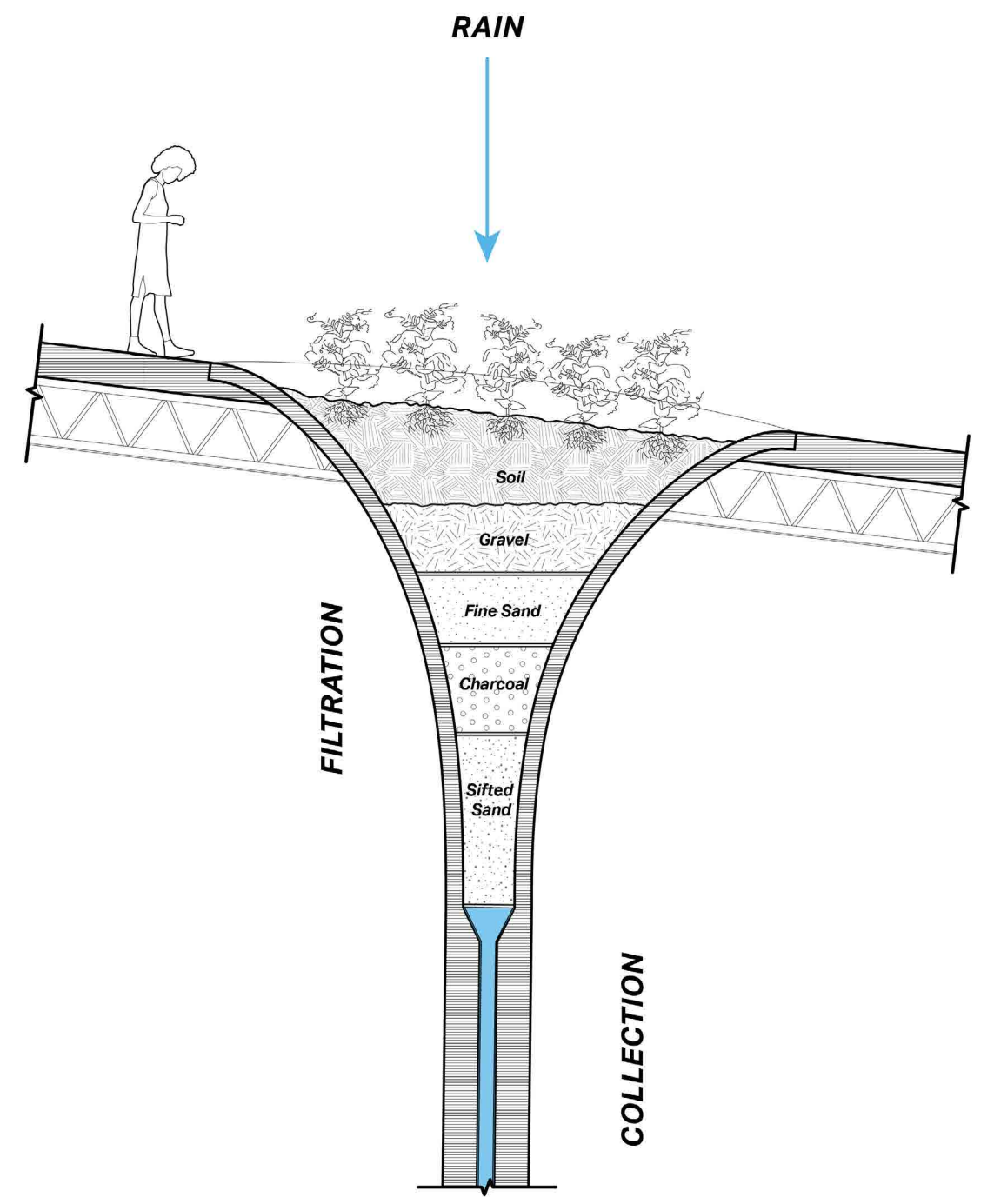

Bridge Column



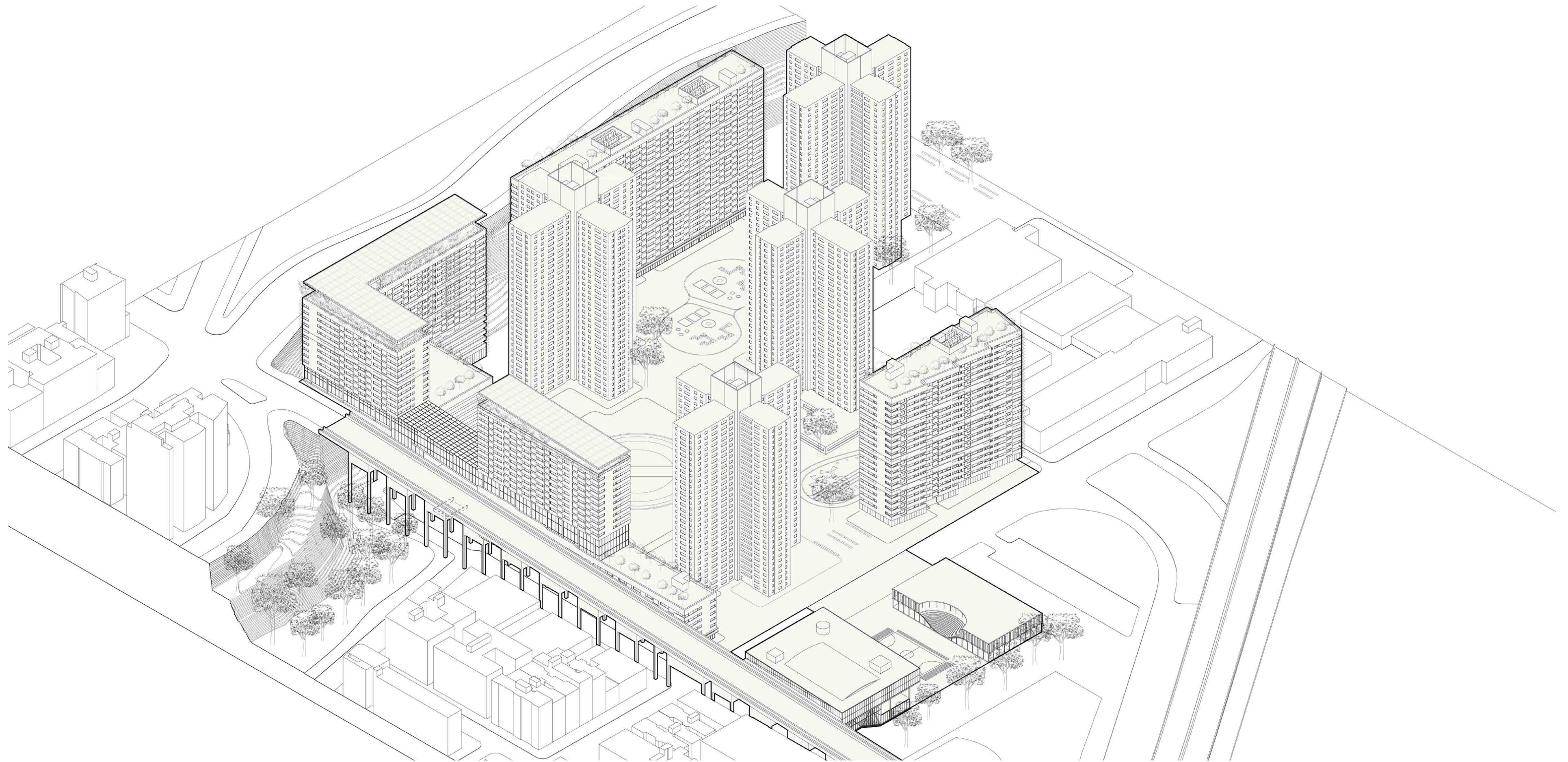

THE PLACE AT VIADUCT

Under the Viaduct: COMMUNITY WELL-BEING IN BRADHURST, HARLEM

Advanced Architecture Studio V, Fall 2021
Instructor : Richard Plunz, Victor Body-Lawson
Collaborator : Jason Young Kim

This studio worked with the Harlem Con- gregations for Com- munity Improvement (HCCI) on design development of concept strategies for community well-being. One of the main goal is rein- vigorating the area under the 155th Street viaduct and develop it into a community focal point.

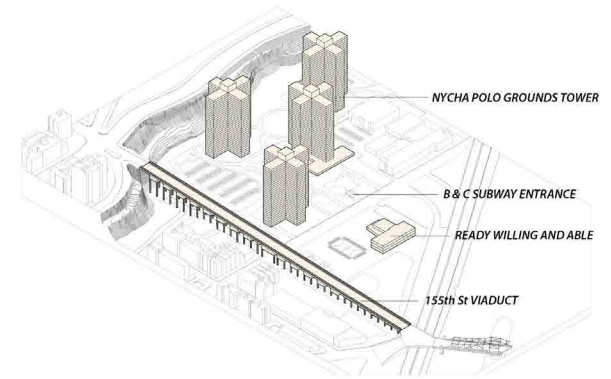
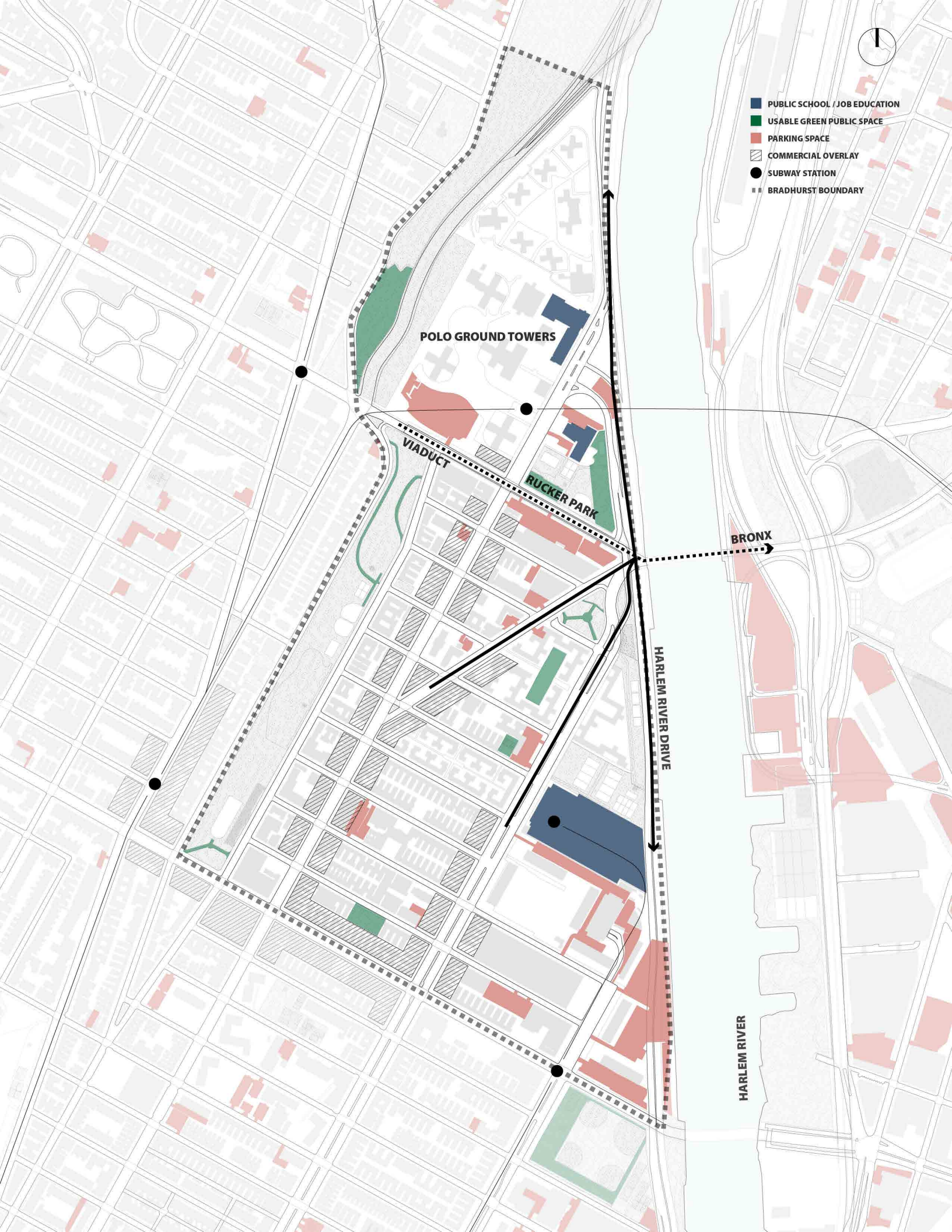

1,614 UNITS
 3,942 RESIDENTS
 1 DAYCARE CENTER
 1 COMMUNITY CENTER
 200 ON-GROUND PARKING SPOTS

EXISTING POLO GROUNDS

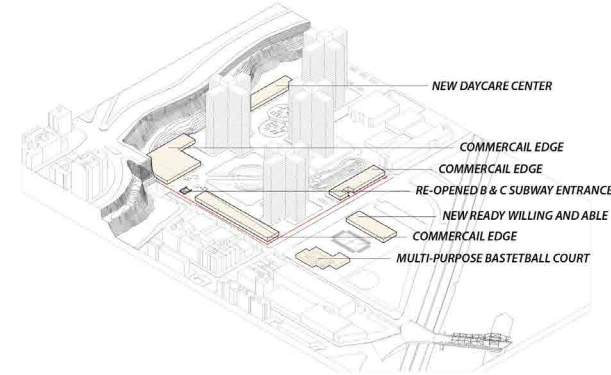

GROUND LEVEL

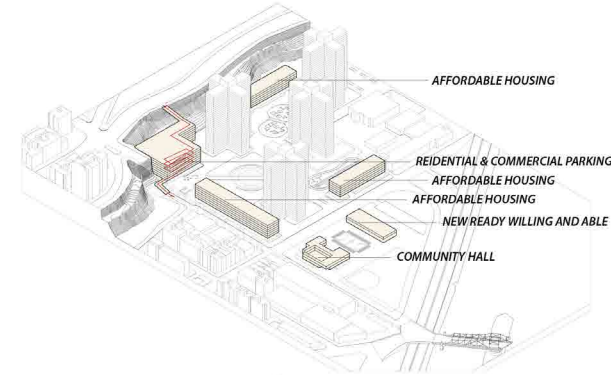

BELOW VIADUCT

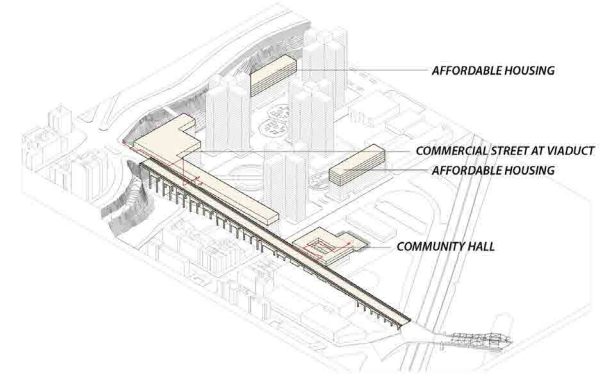

AT VIADUCT

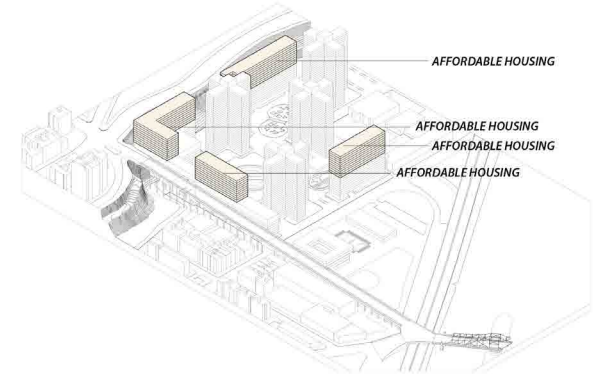

1,145 ADDED UNITS
 323 STUDIO
 321 1 BED ROOM
 353 2 BED ROOM
 148 3 BED ROOM

621 ADDED PARKING SPOTS
 200 REMOVED ON-GROUND PARKING

NEW AREAS
 COMMERCIAL 70,000 sf at GROUND
 13,000 sf at VIADUCT
 COMMUNITY 21,500 sf at GROUND
 OPEN SPACE 25,000 sf at VIADUCT
 COMMUNITY HALL 73,000 sf

ABOVE VIADUCT

Connectivity

Our proposal's theme is the connectivity: between Jackie Robinson Park and Polo Grounds, between the viaduct level 155th street, and the other 155th street below. In doing so, we will focus on the practical problem of the need for affordable housing, commercial and communal facilities at the neighbourhood.

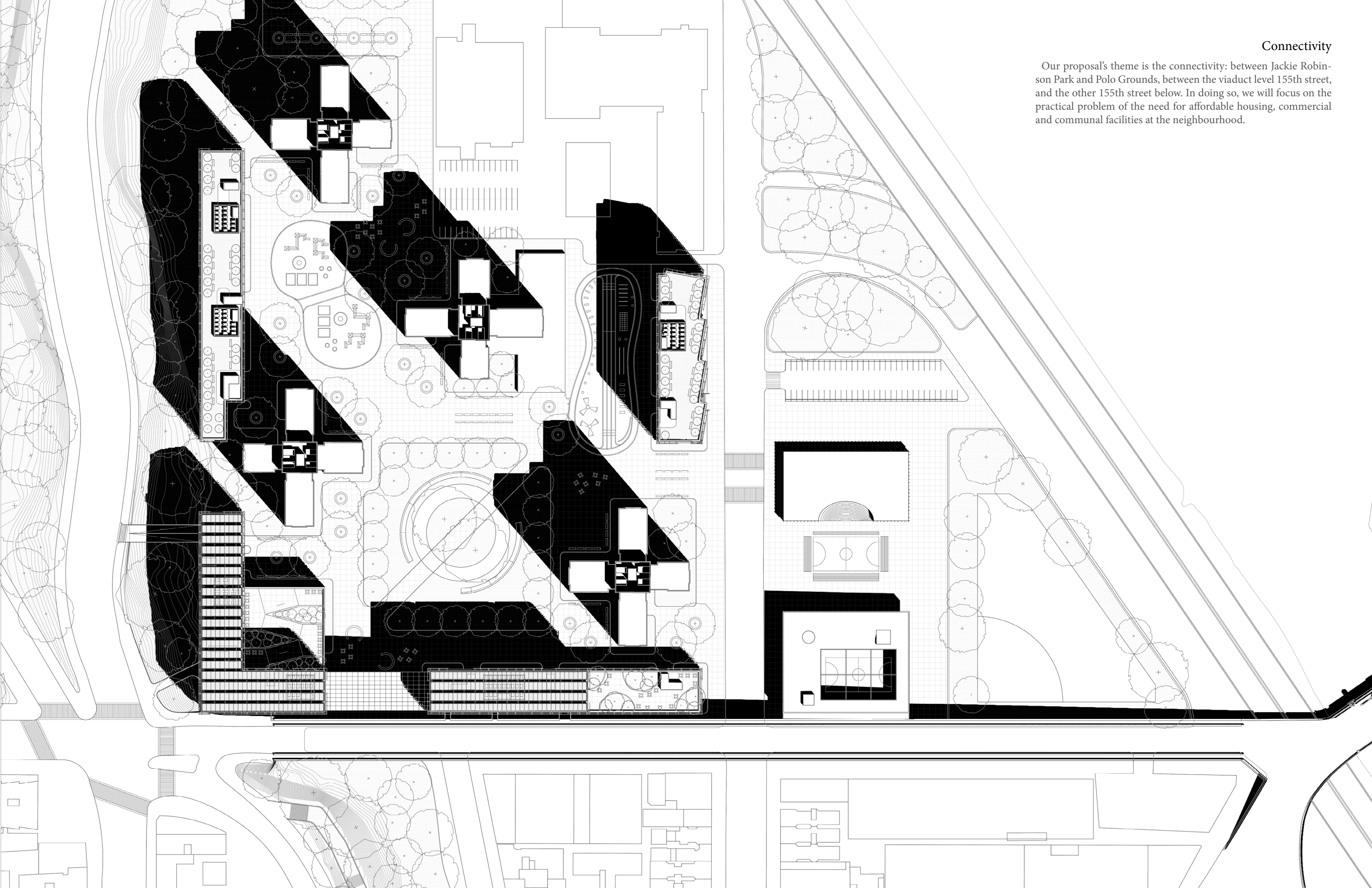



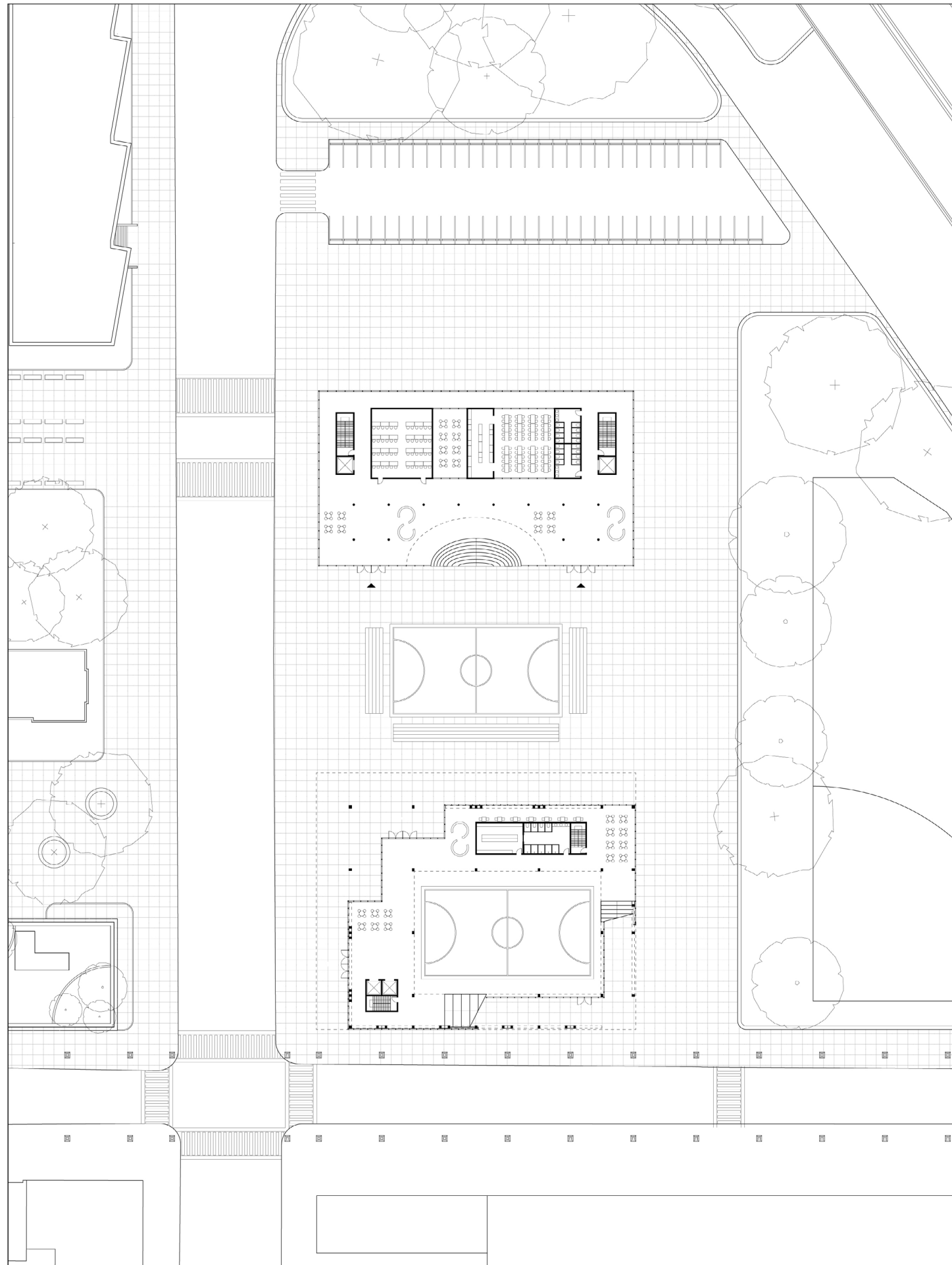

Bradhurst have Ruck park basketball court that the Mecca of Harlem basketball and also have good accessibility to the Yankee stadium. With this context we propose to make a community that related with sports center and sports exhibition program.

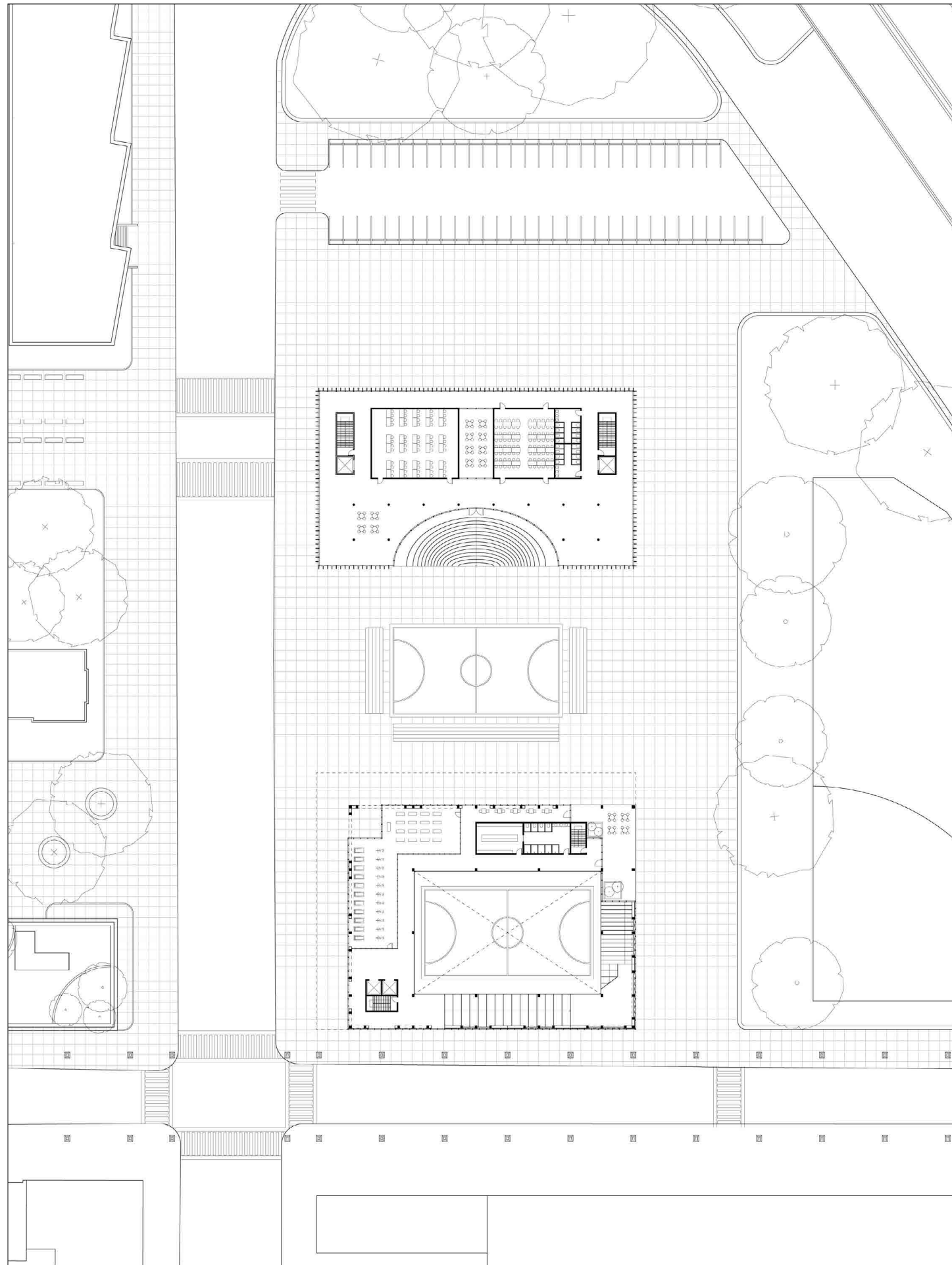

On the ground floor, there is indoor basketball court that can be used to multi-purpose hall for Bradhurst neighborhood and visitor of community center. People also can access from viaduct level to community center.

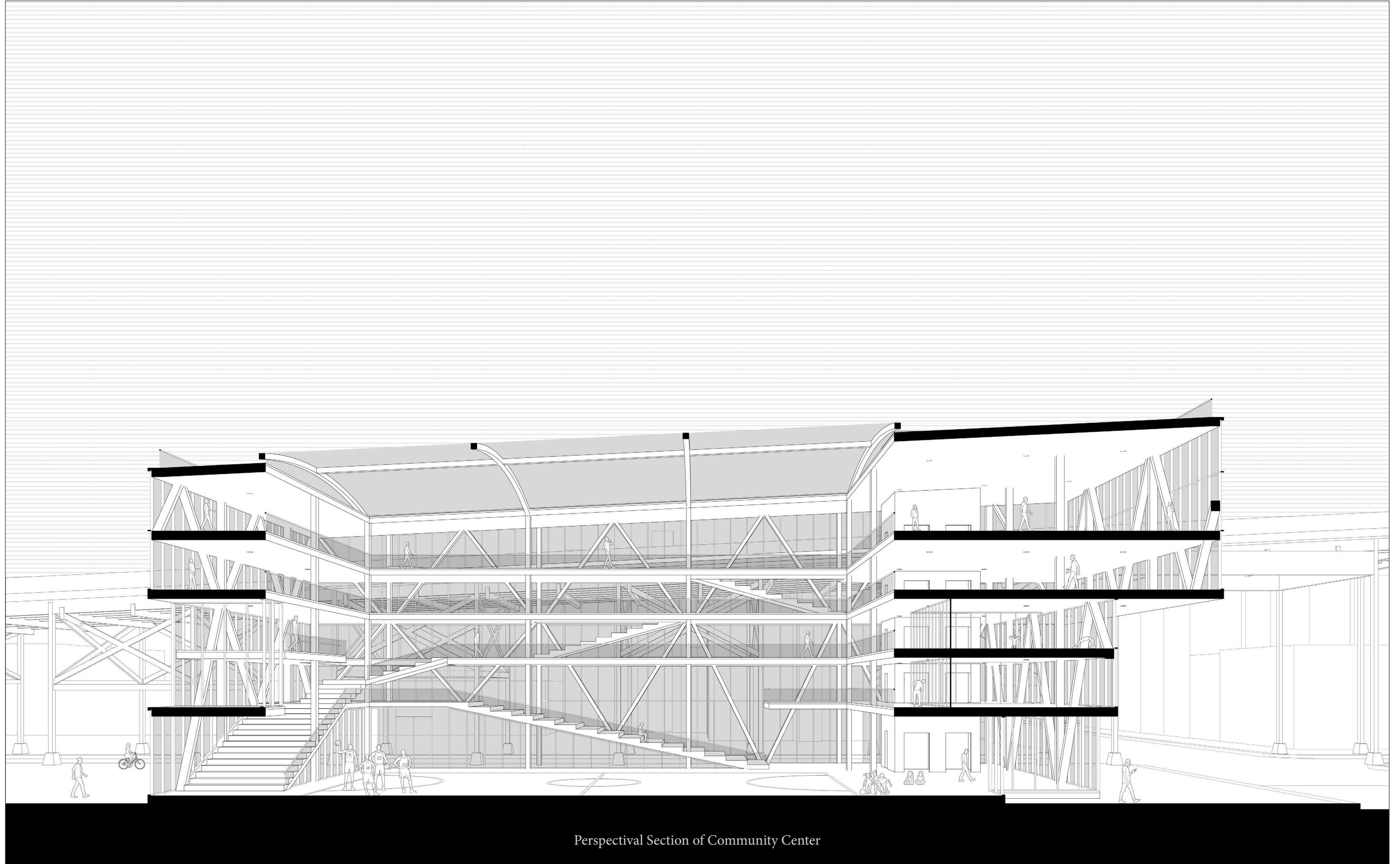

Perspectival Section of Community Center



Perspectival Section of Community Center and Job Education Center

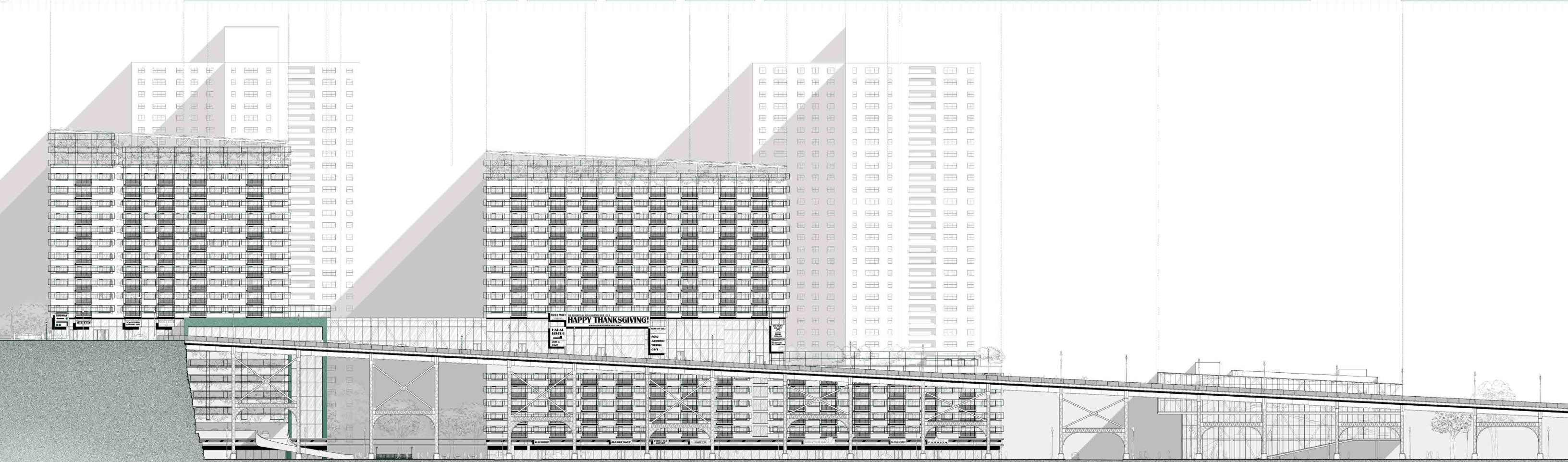
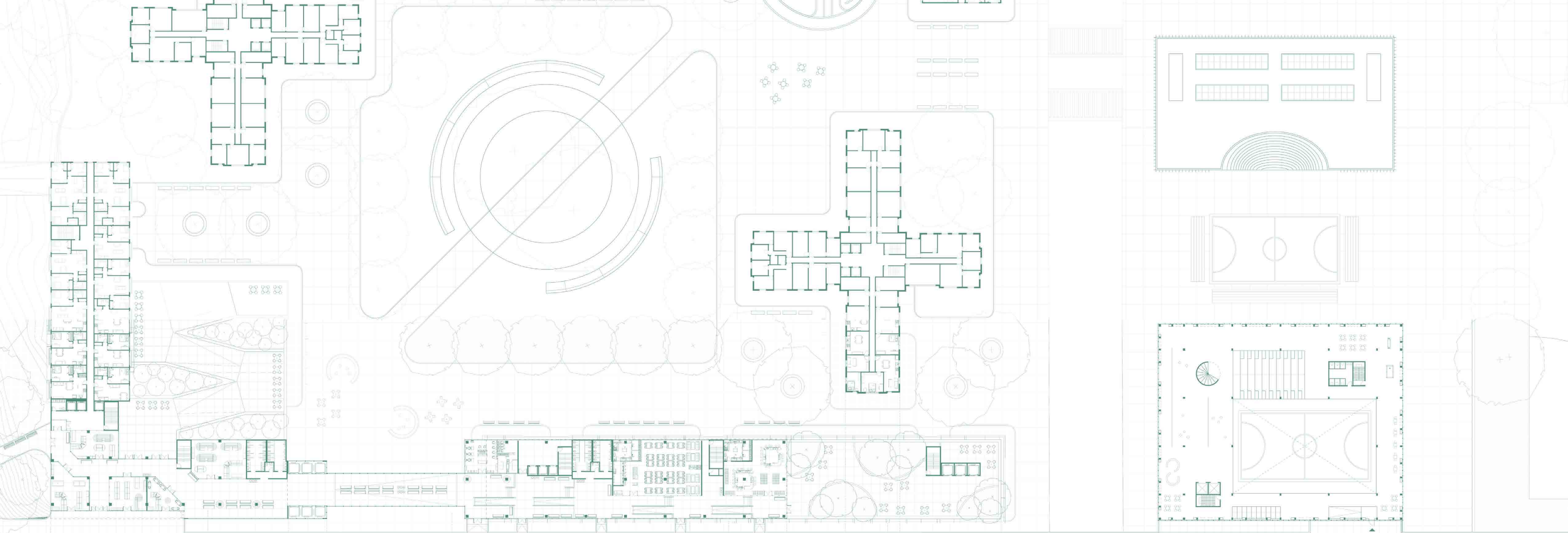

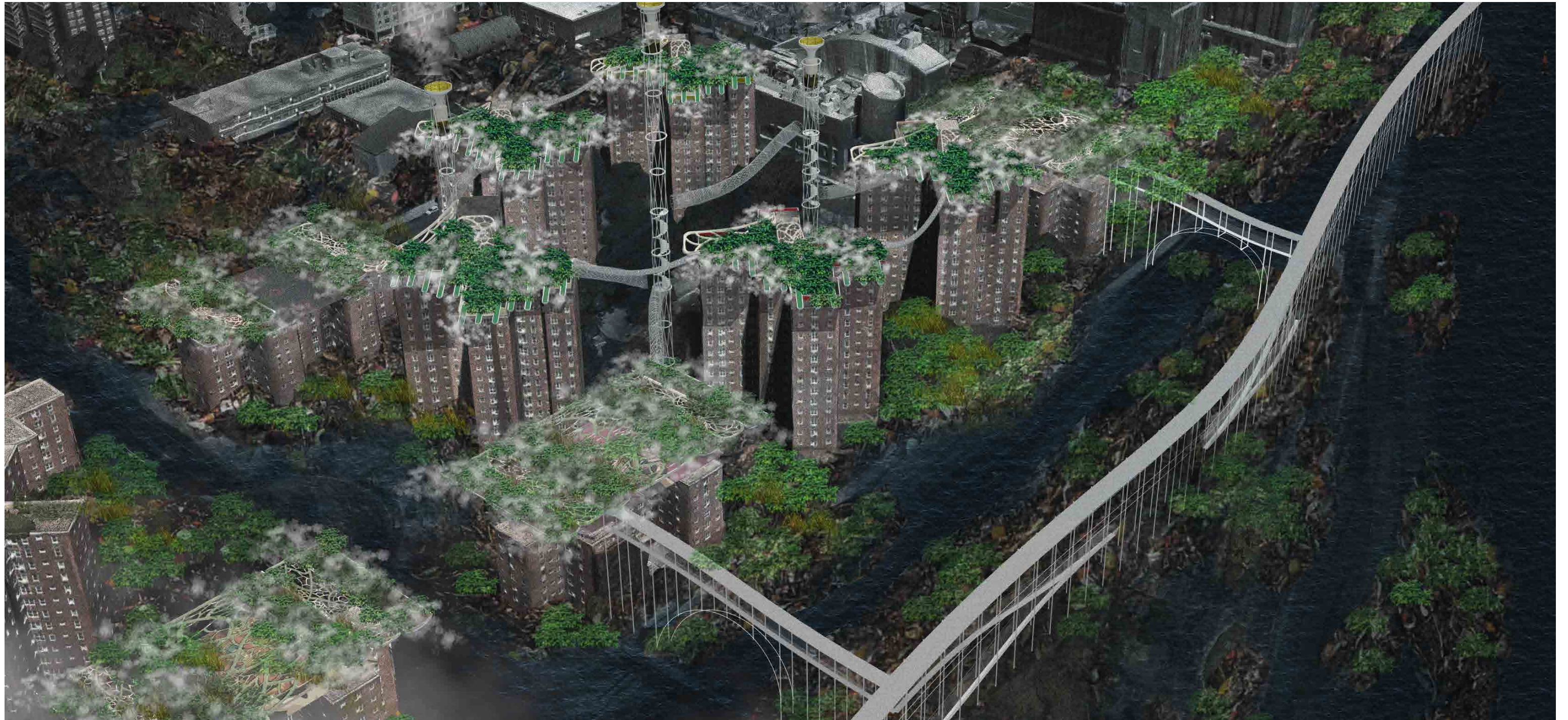

JUMPSEED, A POST-FLOODING FUTURE

(A)cClimatizing Natures or how to intervene with/in them

Advanced Architecture Studio Tutorial, Summer 2021

Instructor : Nerea Calvillo

Collaborator : Ralph Hao-Yuan Cheng, Sujin Shim

How is nature adapting to climate change? Which species are acclimatizing, migrating or disappearing in these changing conditions?

In this project, we focused on who and what migrates because of environmental or social climates, and who has the capacity, the favourable climate/s or the chance to acclimatize to changing conditions. We challenged the notions of native, invasive, endemic or indigenous species; understood the role that climate, culture, politics and society (in the form of power and inequality) play in assigning those categories to different plants and animals; and explore forms of intervention to (a)cclimatize them.



Good and Bad Natures?

Western framings of the environment have distinguished between good and bad nature. Economically productive, beautiful or easy to control natures are good. Invasive, migratory, uncontrollable or dull natures are bad. This distinction has consequences in what is protected or removed, colonised or abandoned. These binaries are challenged when looking at nature ecosystemically, revealing the violence and potential of each species.



JUMPSEED | A Backup Plan for Vulnerable Entities

Global Warming is turning “extreme weather events” into normality. Recently in Manhattan, there have been many massive floods. Non-human lives are losing their habitat because of flooding. By adopting the power of JUMPSEED, a new habitat will be developed on the roof tops, to adapt to the flooding future.

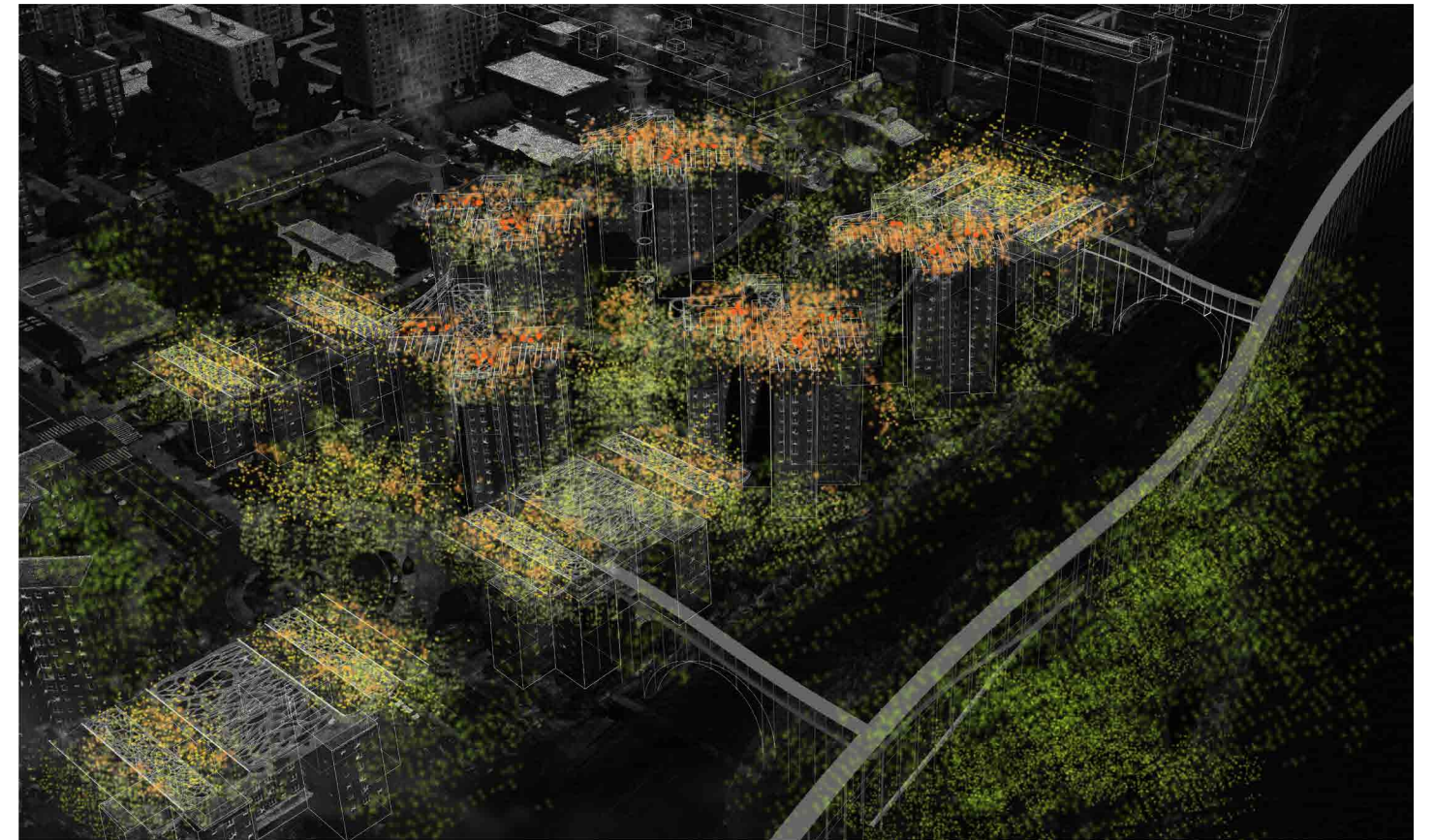
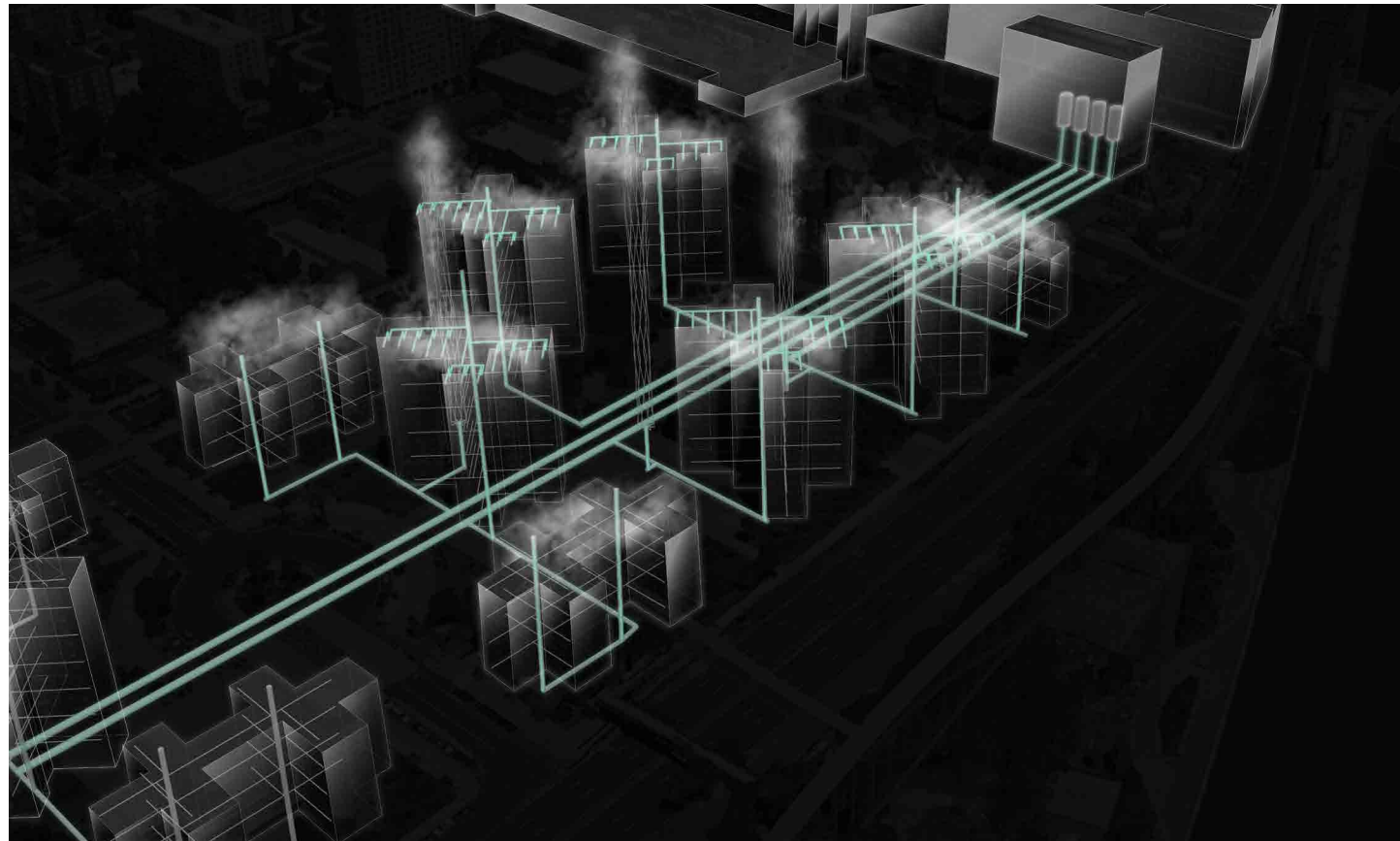

Con-Edison, the most important power source of the city, provide them with free steam energy, which is a secondary product of the power plant. 24. Through the meshes installed, the steam will provide humidity and condense into water to support JUMPSEED. The meshes will also accommodate the bee hives and bird nests to provide shadows underneath.

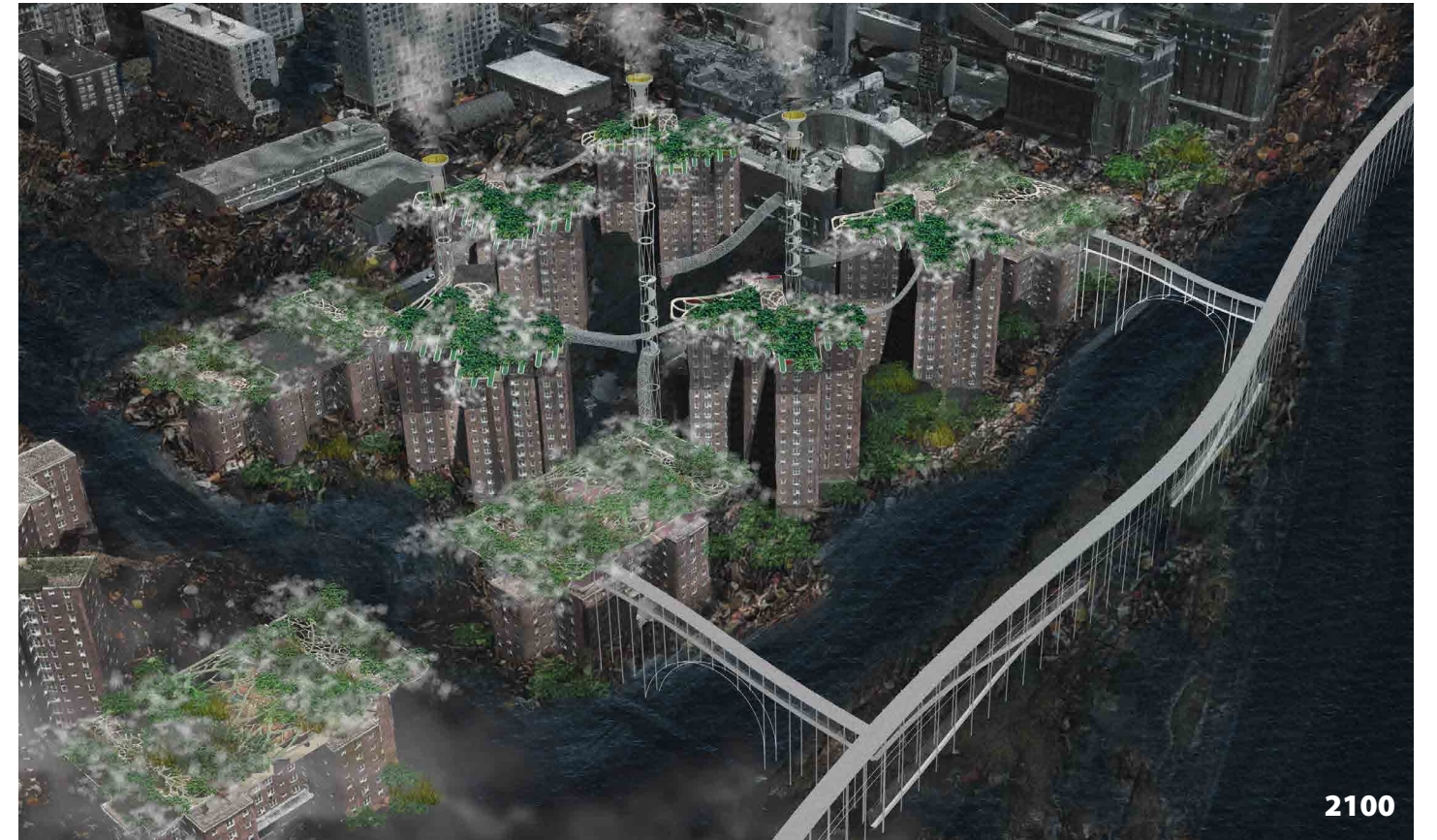
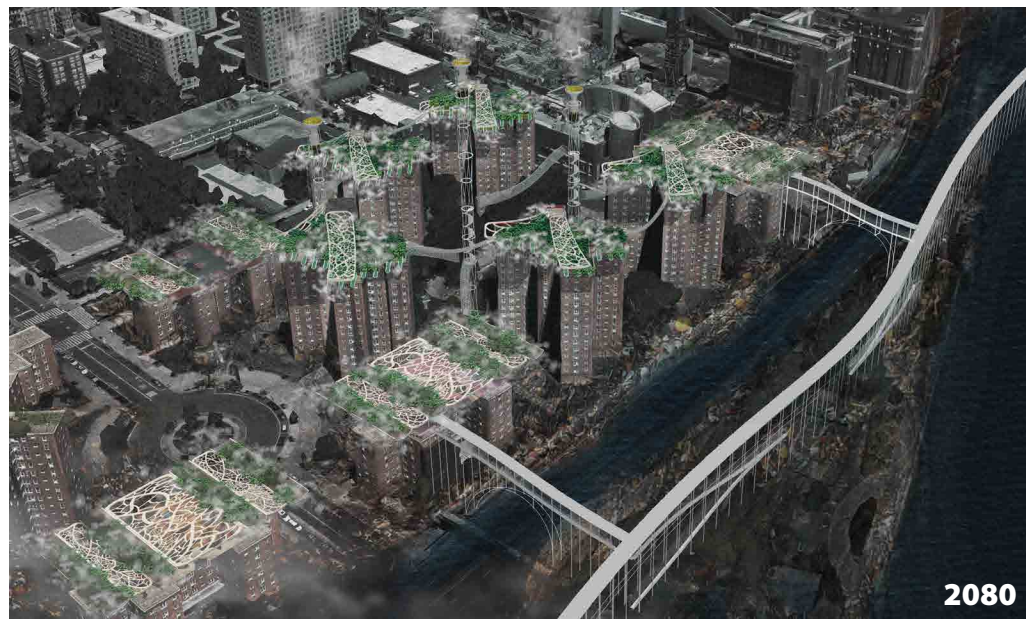
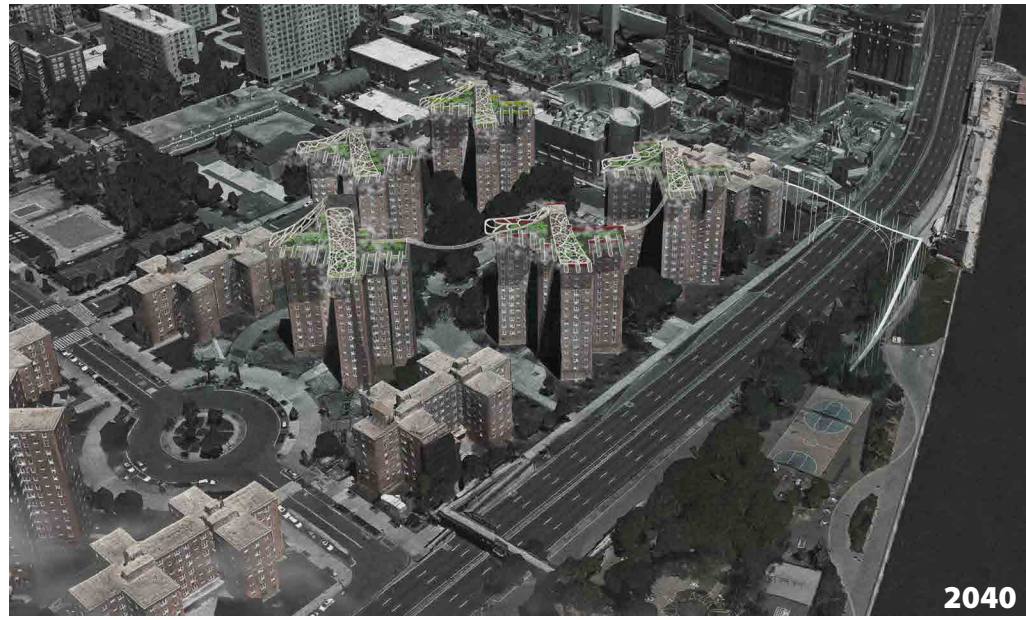

Despite JUMPSEED's unremarkable appearance, they will help both human and non-human lives to build up new habitats and keep the hope for the post-flooding future.

MODULAR CONSTRUCTIVISM

Tiling and Modular Fabrication

Transitional Geometries, Fall 2021

Instructor : Joshua Jordan

This project is an abstract study of tiling principles, which looked at different tileable 'frame' conditions. Strategically-placed nodes overlaid on these frames allowed the tile to be flipped and rotated so that adjacent nodes formed new relationships; these adjacent relationships allowed a single tile to create a seemingly random pattern over a large surface.

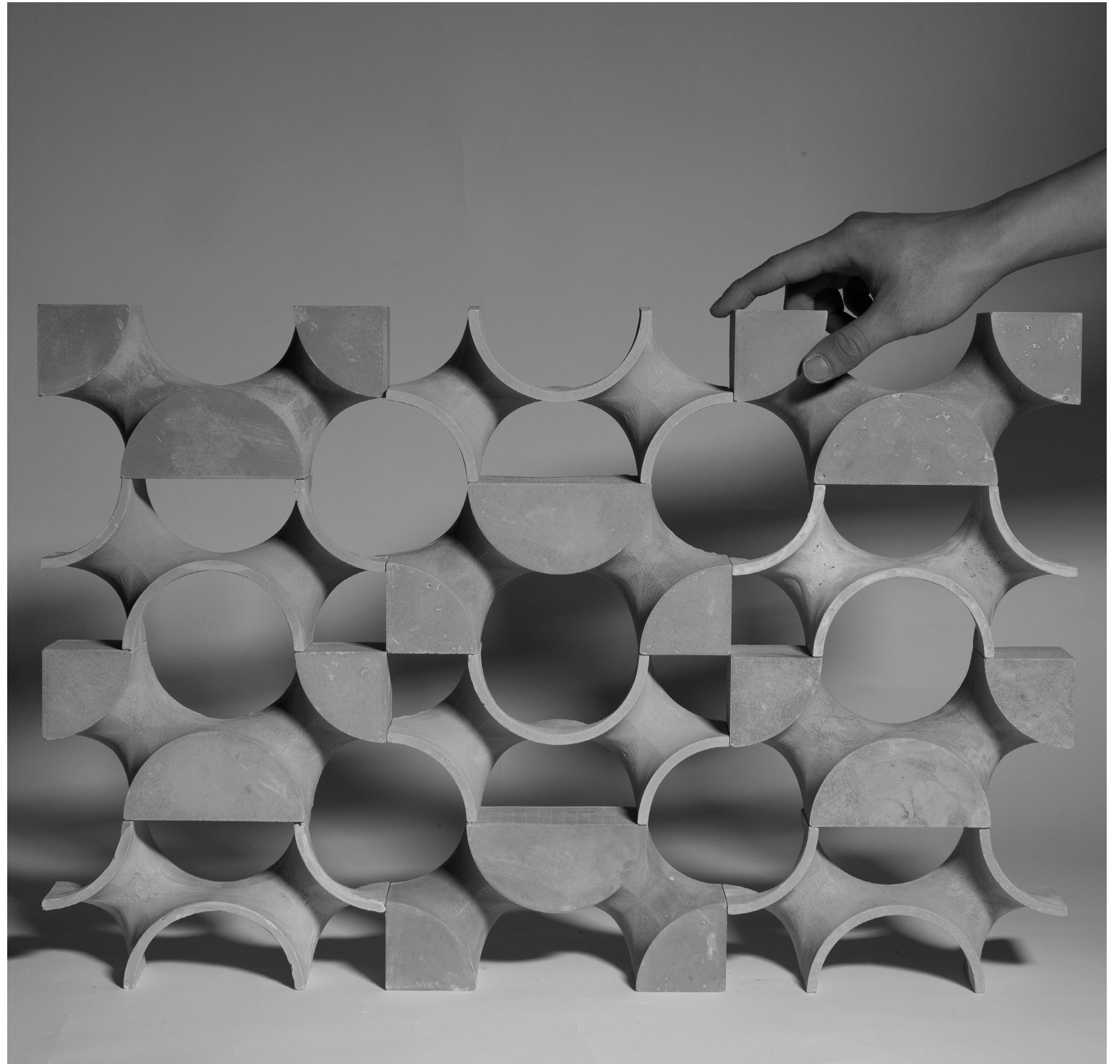

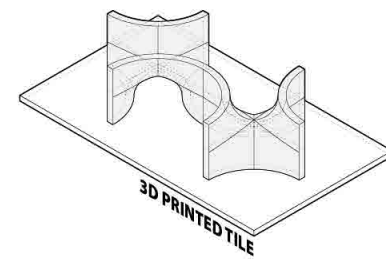

3D PRINTED TILE

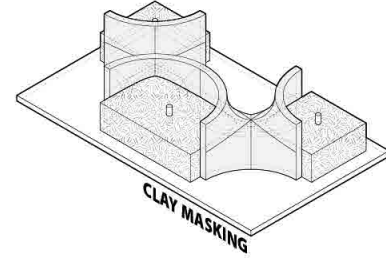

CLAY MASKING

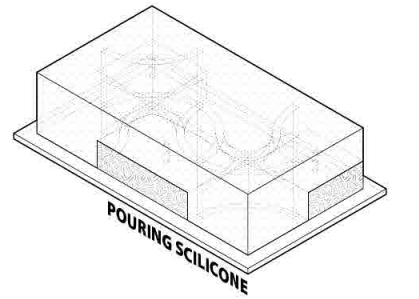

POURING SCILICONE

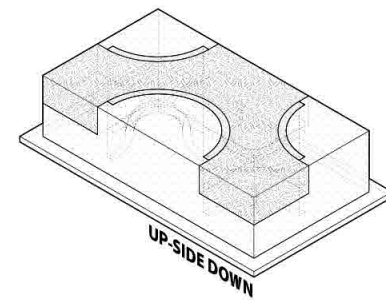

UP-SIDE DOWN

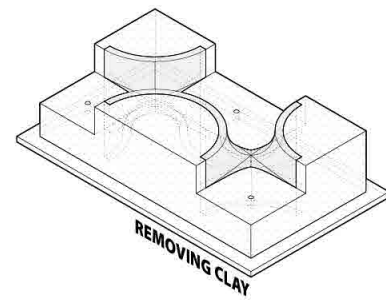

REMOVING CLAY

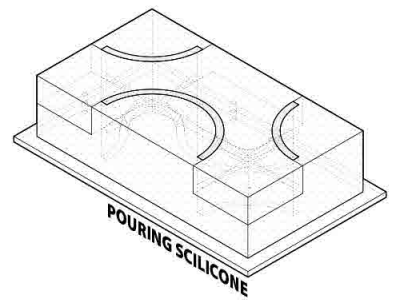

POURING SCILICONE

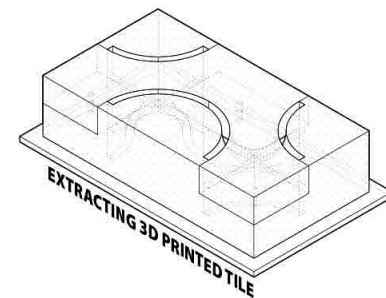

EXTRACTING 3D PRINTED TILE

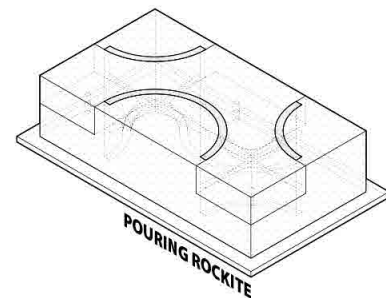

POURING ROCKITE

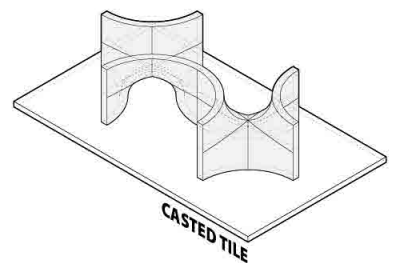

CASTED TILE

