

P O R T F O L I O
Y U K U N T I A N
S E L E C T E D W O R K S 2 0 2 1 - 2 0 2 2

CONT

01 LIBRARY FOR J

02 WATERFRONT ACCESS

03 NETWORK (ART &

04 GENERATIVE DESIGN_PALAC

05 RETHINKING BIM_DAYLIGH

06 FACADE DETAILING_NE

ENTS

JACKSON HEIGHTS

& COMMUNITY AMENITIES

DESIGN INCUBATOR)

THEATER VIEW OPTIMIZATION

IT AND 'VALUE' OPTIMIZATION

W CURTAIN WALL DESIGN



01 LIBRARY FOR JACKSON HEIGHTS

Academic Project

Location: Jackson Heights, Queens, NY

Instructor: Eric Bunge, Mimi Hoang

Group Work: Yukun Tian, Yunlong Fan

Summer 2021

The population density of Jackson Heights is very high and most of the residents are not well educated. Also people hold different kinds of festivals at different times in Jackson Heights. New problems arise, limited events space, limited office, and limited learning space. **In order to face those challenges, we want to redefine the library.** we remix new functions such as diversity plaza, service center, free office room, language room and digital reading room. We combine those functions with three areas called **Block**. By analyzing the characteristics of each block, find its advantages, combine with library functions, and solve problems.

How to contact each block? We use the bookshelf as our architecture language, creating a new mode of interaction between indoor and outdoor. People can create a potential connection through a book. More importantly, bookshelves will serve as a medium for connecting indoors and outdoors. **As a result, in the horizontal and vertical divisions of bookshelves and greening shelves, outdoor space, facade, threshold, indoor reading space, outdoor sidewalk, subway station, bus station, roof garden, these architectural elements attract and merge with each other and finally become parts of the library.**

AREA DEMOGRAPHICS

Race/ Background



Race/ Background	Jackson Heights	Queens	NYC
Hispanic or Latino (of any race)	50%	28%	29%
White alone	15%	26%	32%
Black or African American alone	1%	17%	22%
Asian alone	32%	25%	14%
Two or more races	1%	2%	2%
Some other race alone	1%	2%	1%
American Indian and Alaska Native	0%	0%	0%
Native Hawaiian and Other Pacific Islander	0%	0%	0%

SITE ANALYSIS

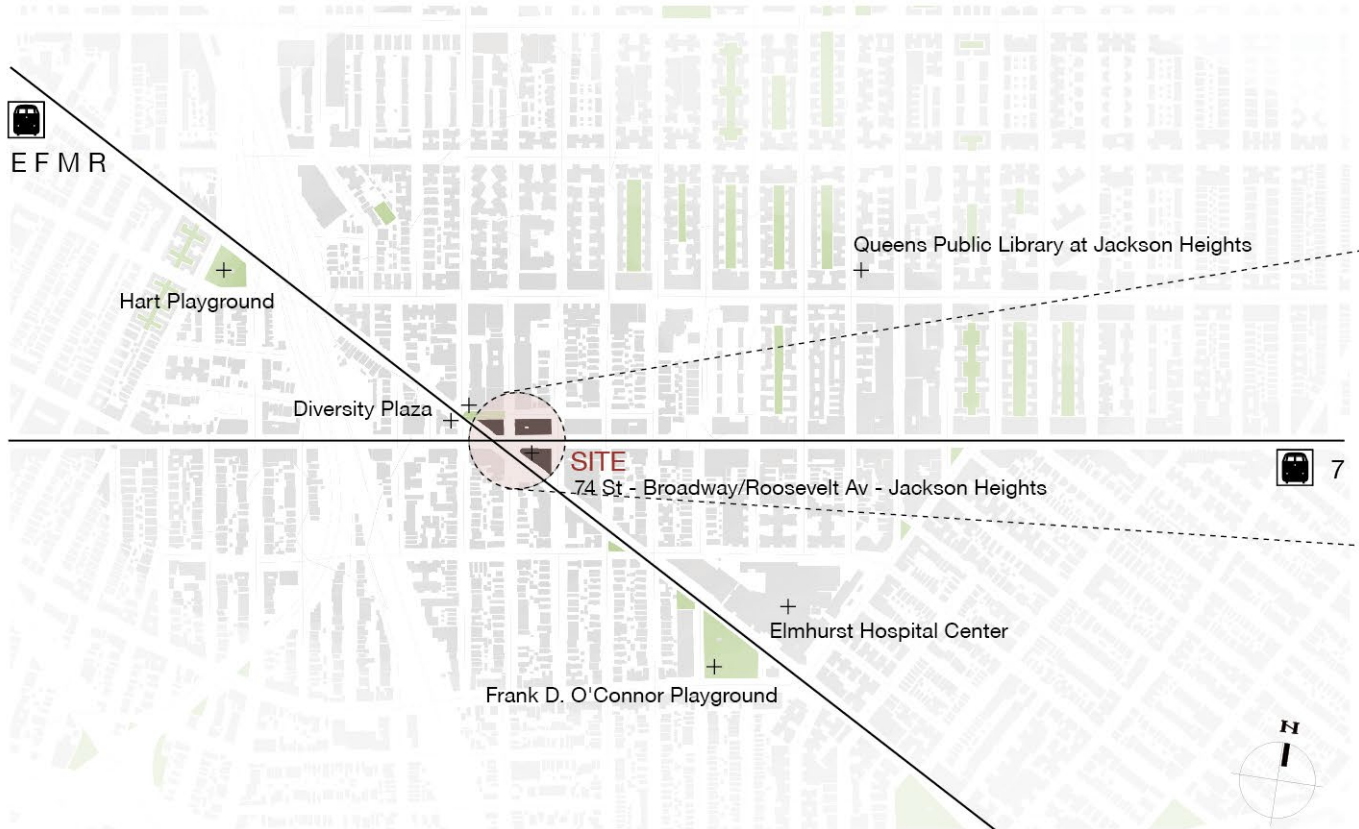

Neighborhood Events

Chatpati Mela
 Diwali and Dashain celebrations
 Flower Parade (Desfile de las Flores)
 Halloween Parade
 Pahela Baisakh
 Queens Pride
 Ramadan, Eid, and Chaand Raat celebrations
 Viva la Comida

Merchant & Business Groups

74th Street Merchants Association
 82nd Street Partnership
 Business Center for New Americans
 Jackson Heights Bangladeshi Business Association
 Jackson Heights Merchants Association
 Queens Business Outreach Center
 Renaissance Economic Development Corporation

Educational Attainment



	Jackson Heights	Queens	NYC
12th Grade or Less, No Diploma	25%	19%	19%
High School Graduate	26%	27%	24%
Some College, No Degree	11%	15%	14%
Associate's Degree	8%	8%	7%
Bachelor's Degree	20%	20%	21%
Graduate or Professional Degree	10%	11%	15%

FUNCTION REMIX

COMBINE WITH COMMUNITY & STREET

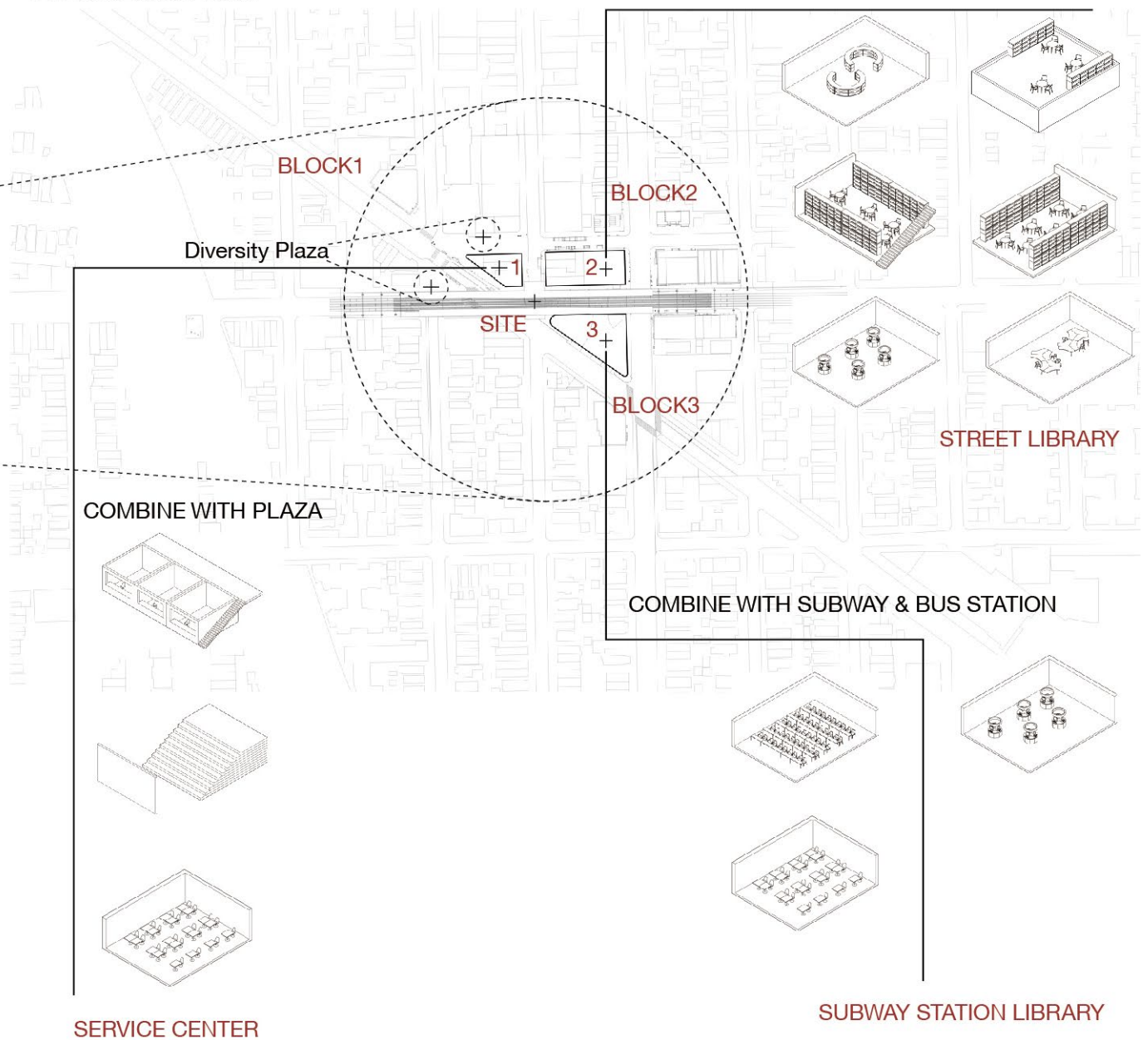

SERVICE CENTER

SUBWAY STATION LIBRARY

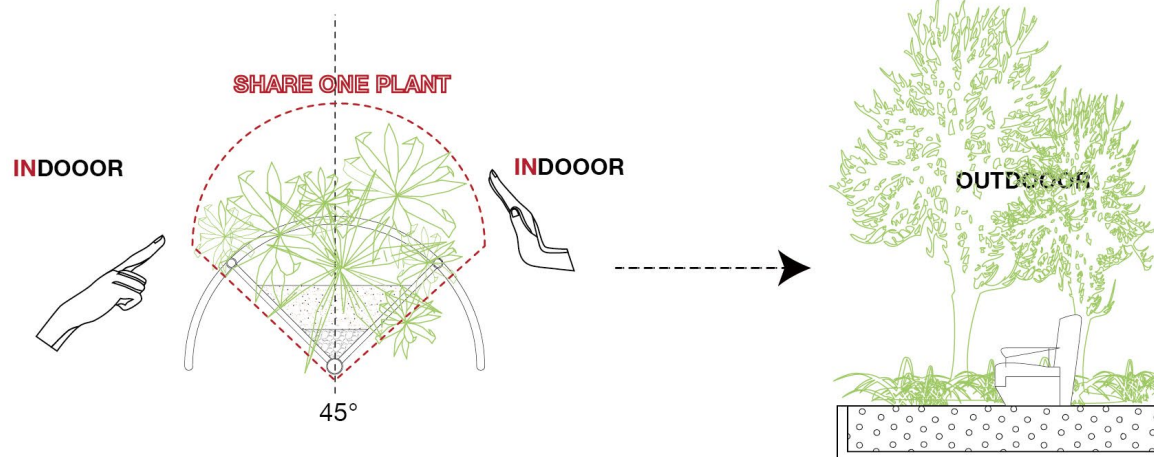
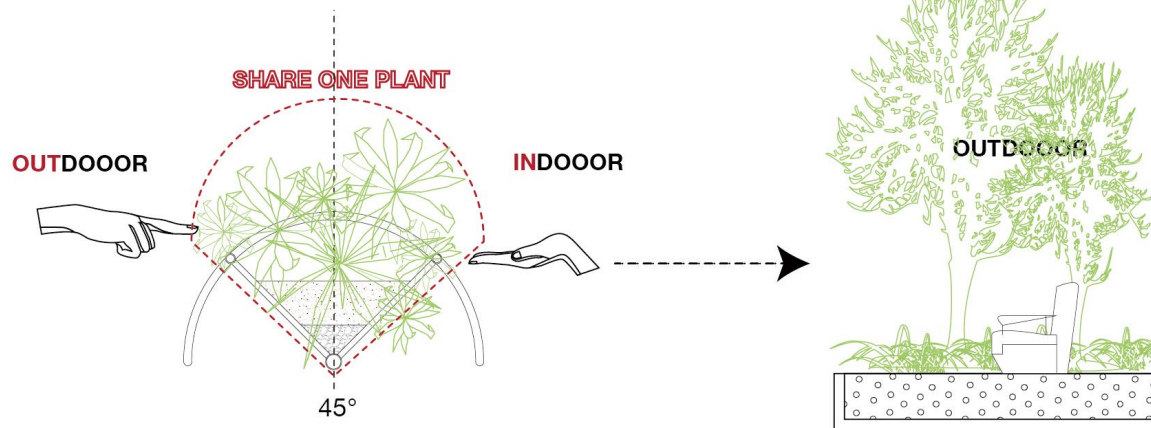
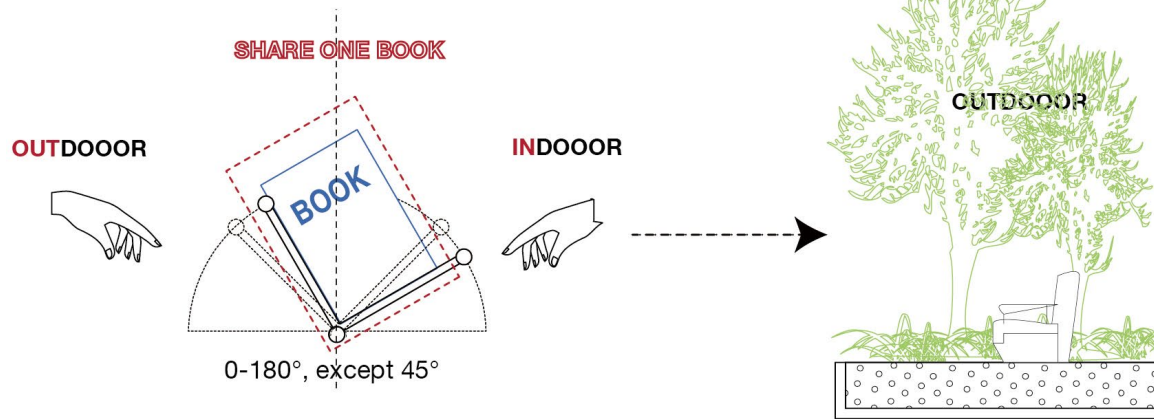
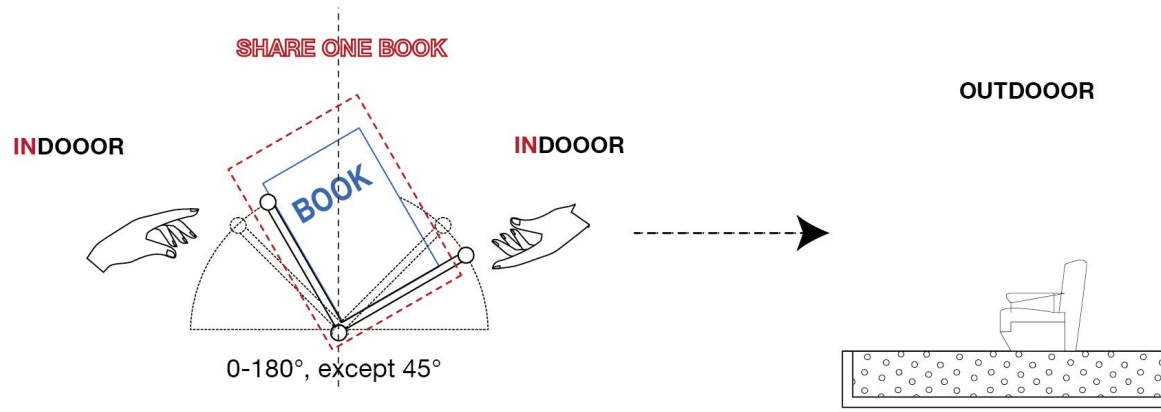

Architectural Language

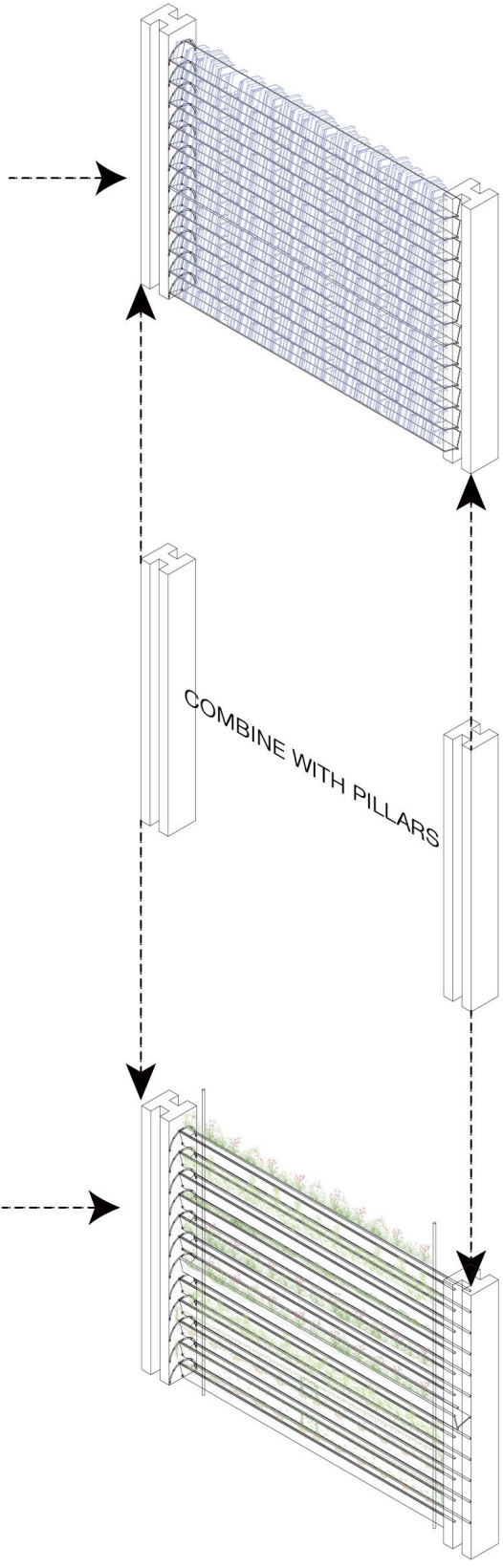
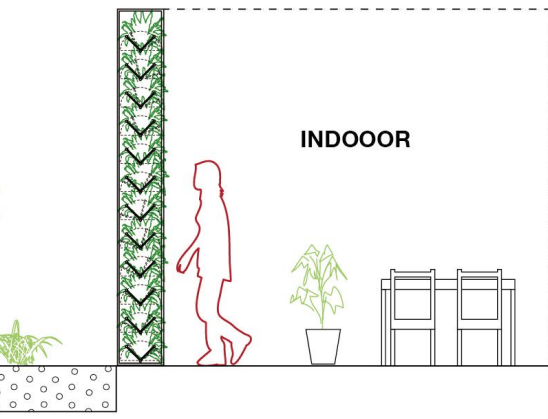
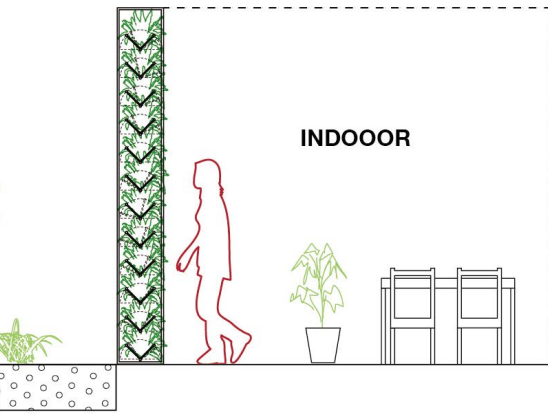
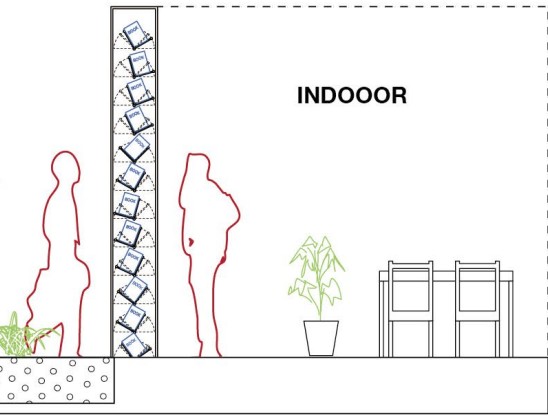
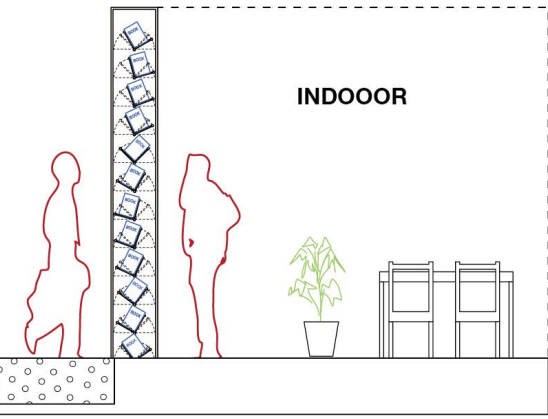



SECOND PLAN

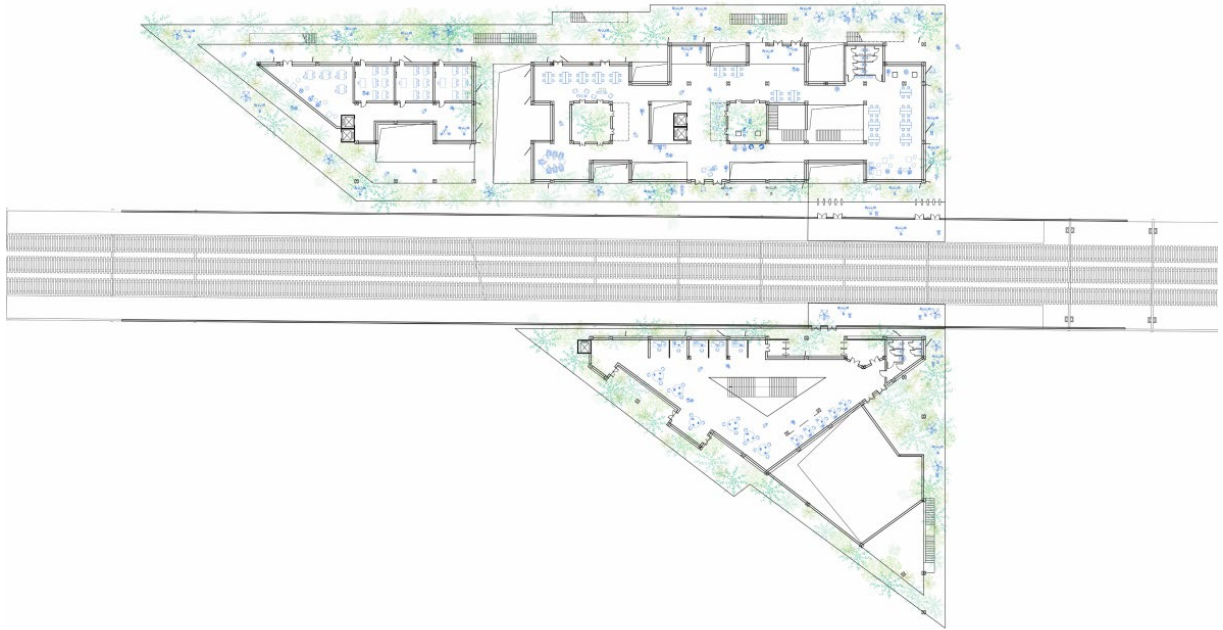

THIRD PLAN



FOURTH PLAN

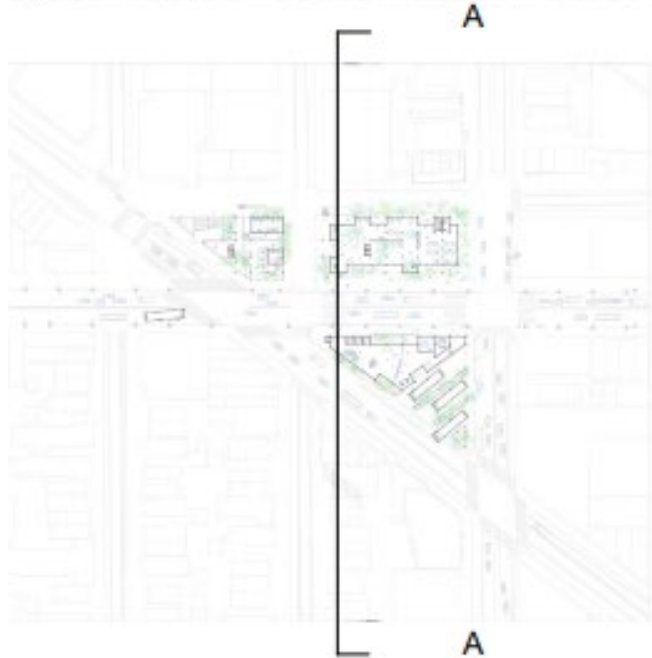
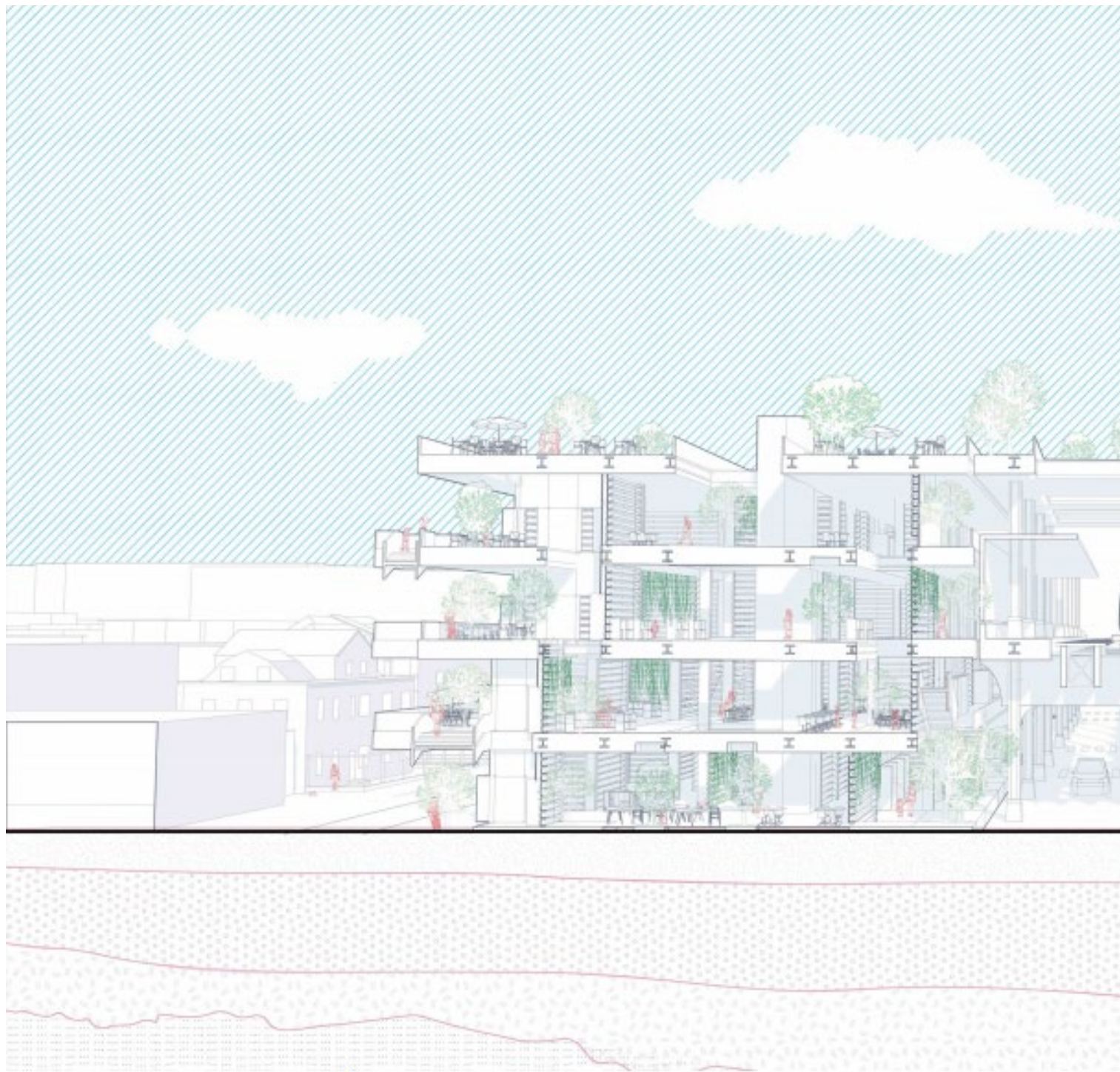

Section

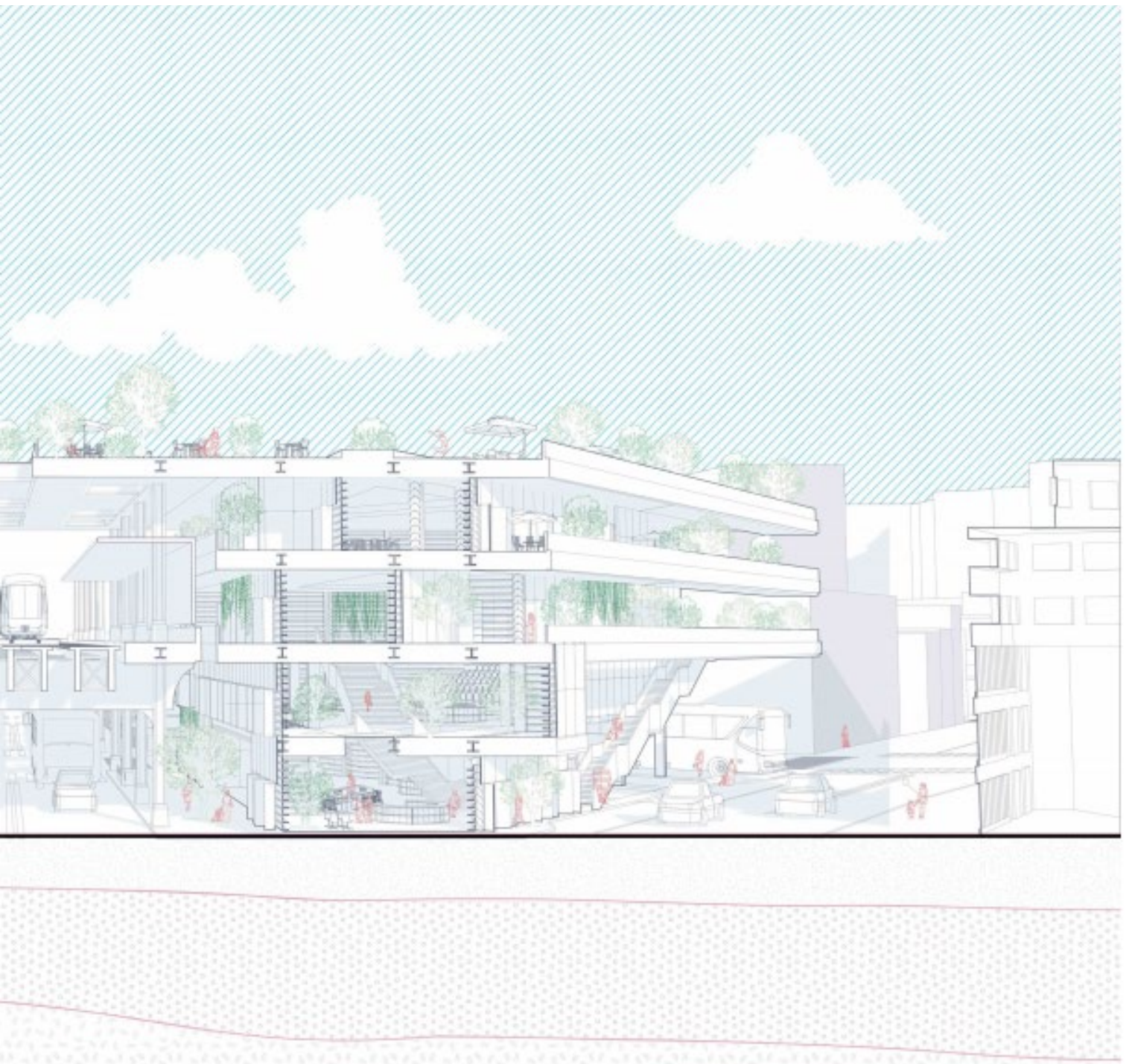

Section A-A

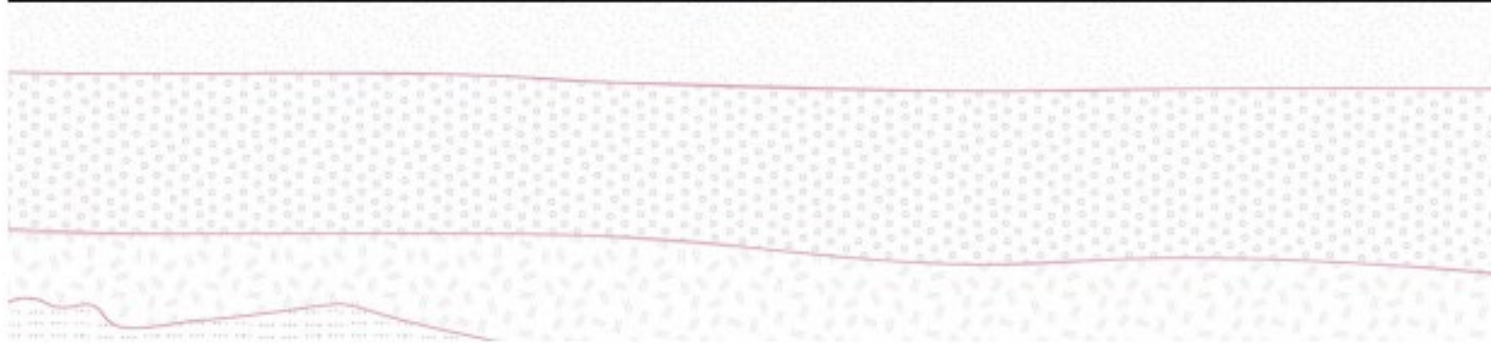

Section

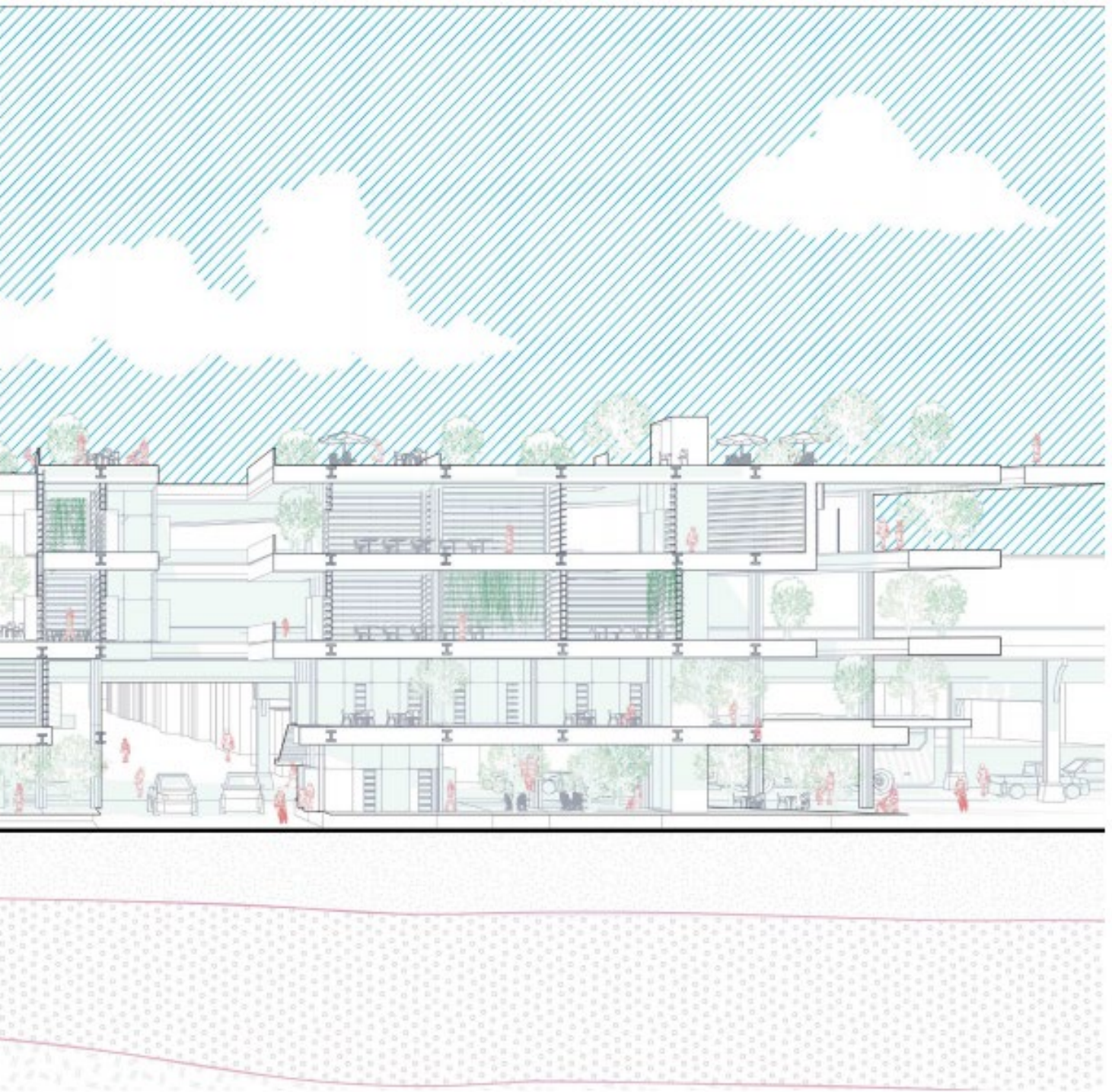

on B-B



Roof Garden



Immersive Image



Immersive Image-Outdoor Corridor

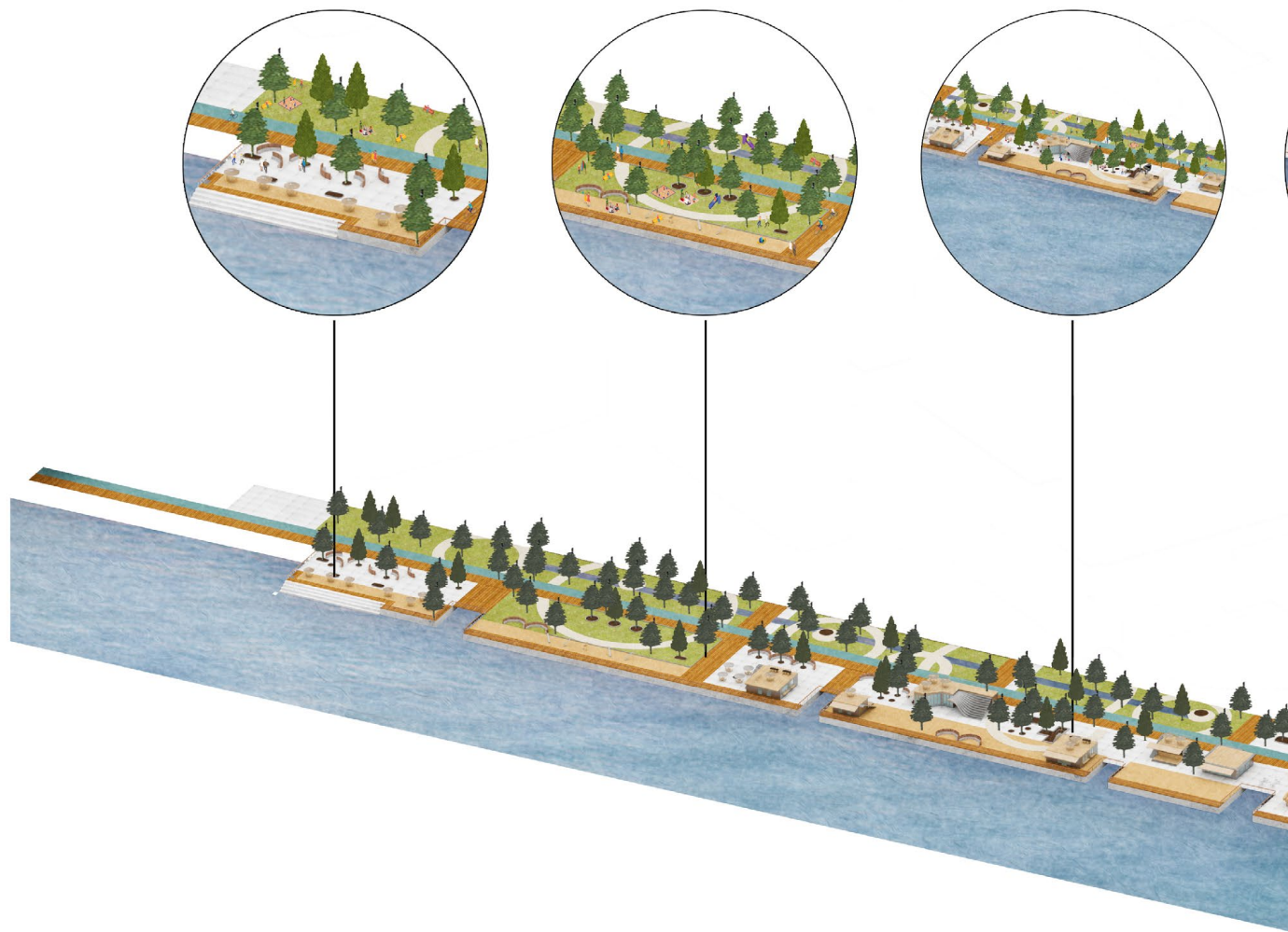

Based on its long engagement with the Bradhurst community, we translated the BOA project into HCCI's goals. In our project, we designed a new waterfront park and education center. Through this program, we can create employment, job training and youth recreational/educational opportunities for the local community; create appropriate waterfront access, shoreline and habitat restoration and recreational use opportunities; reinvigorate the area under the 155th Street viaduct and develop it into a community focal point.

02 WATERFRONT ACCESS & COMMUNITY AMENITIES

*Academic Project
Location: Bradhurst, Harlem, NY
Instructor: Victor Body-Lawson, Richard Plunz
Group Work: Yukun Tian, Yunlong Fan
Fall 2021*

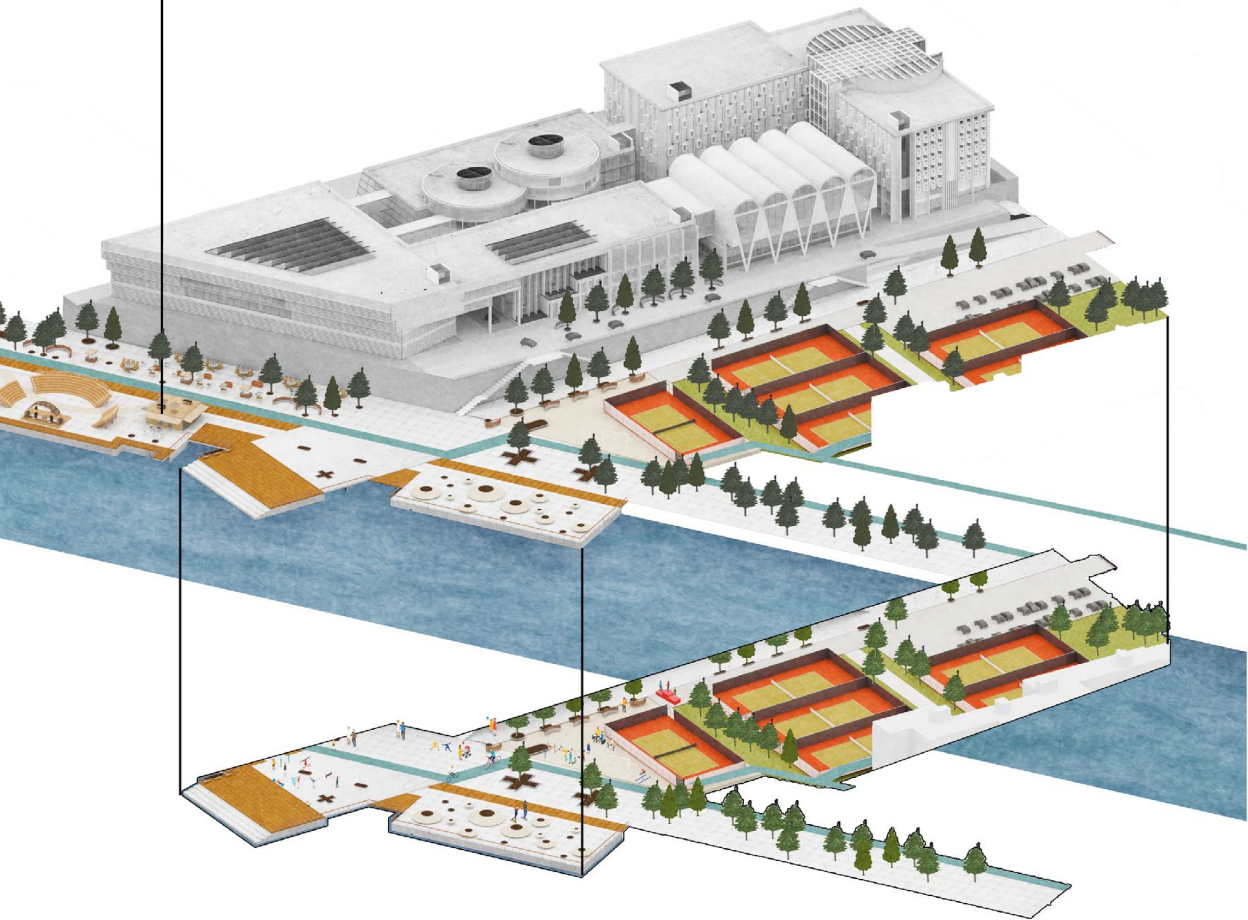

Site Analysis

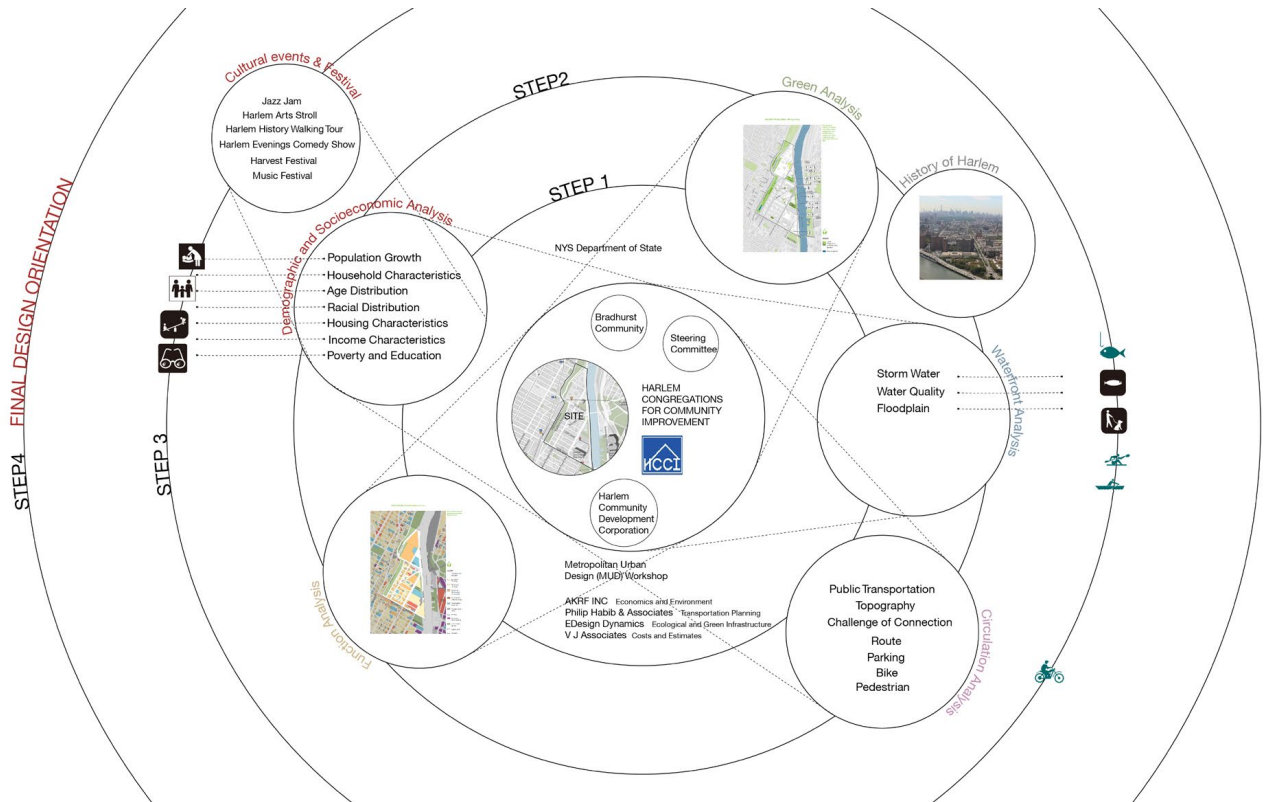

Design Progress

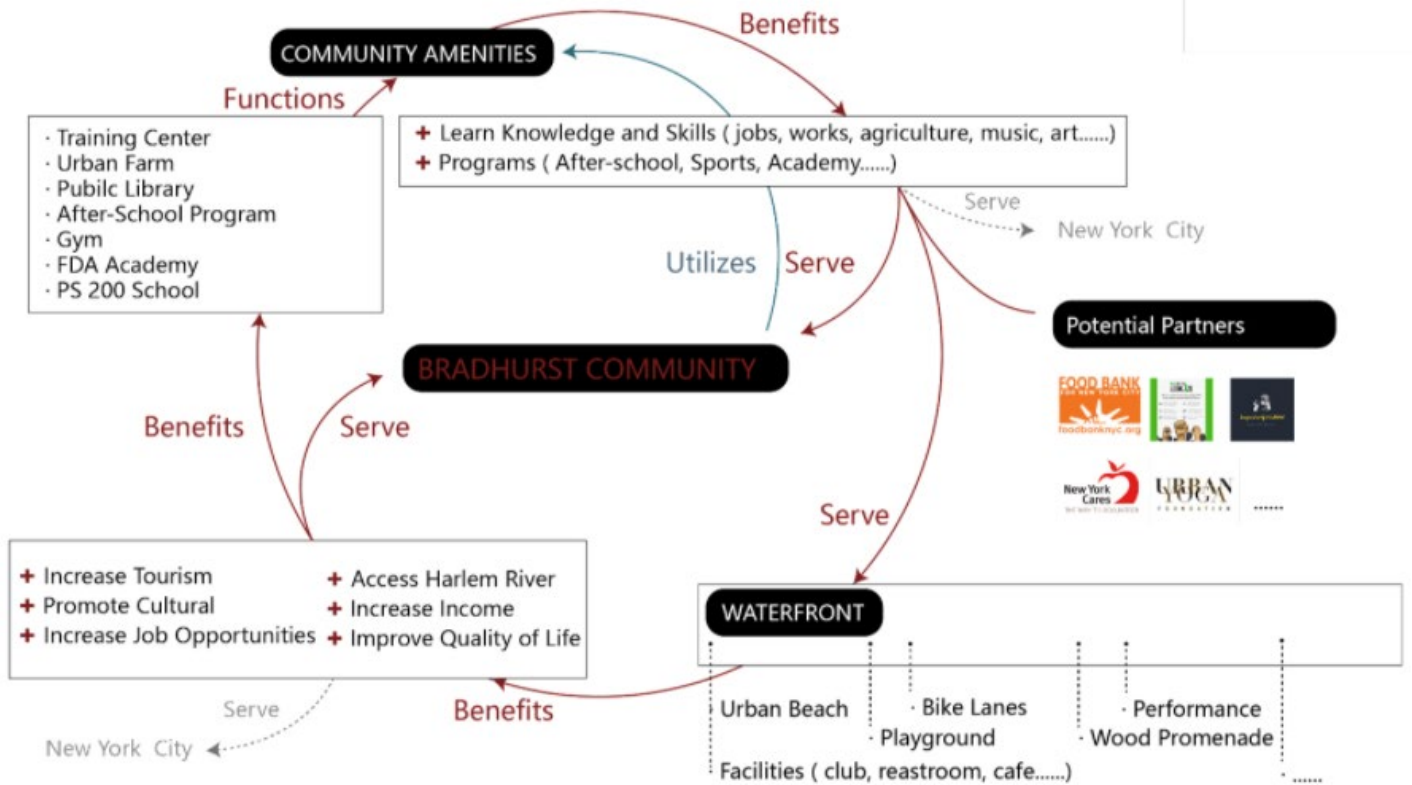

Plan

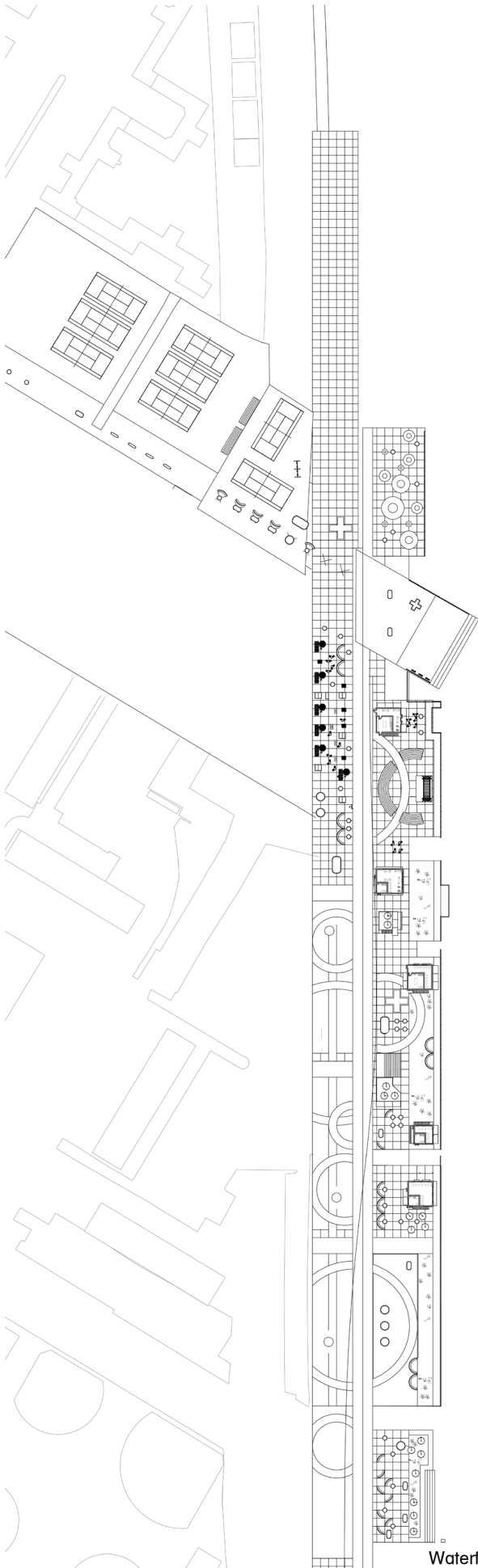

Waterfront Plan

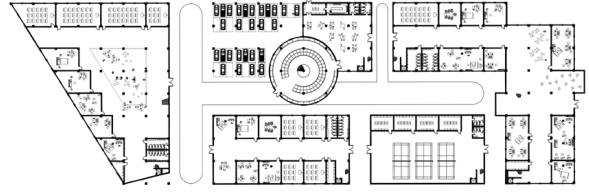

1F

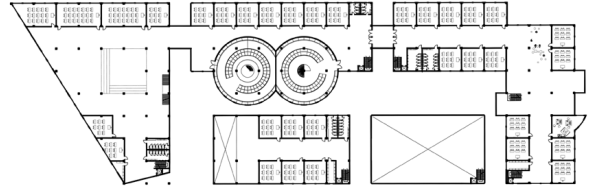

2F

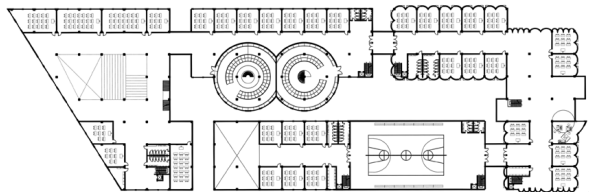

3F

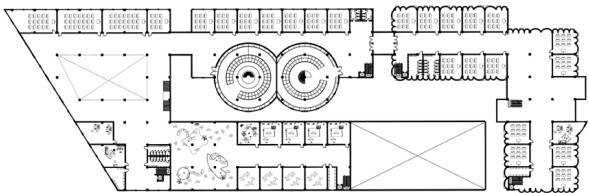

4F



5F



6F



7F

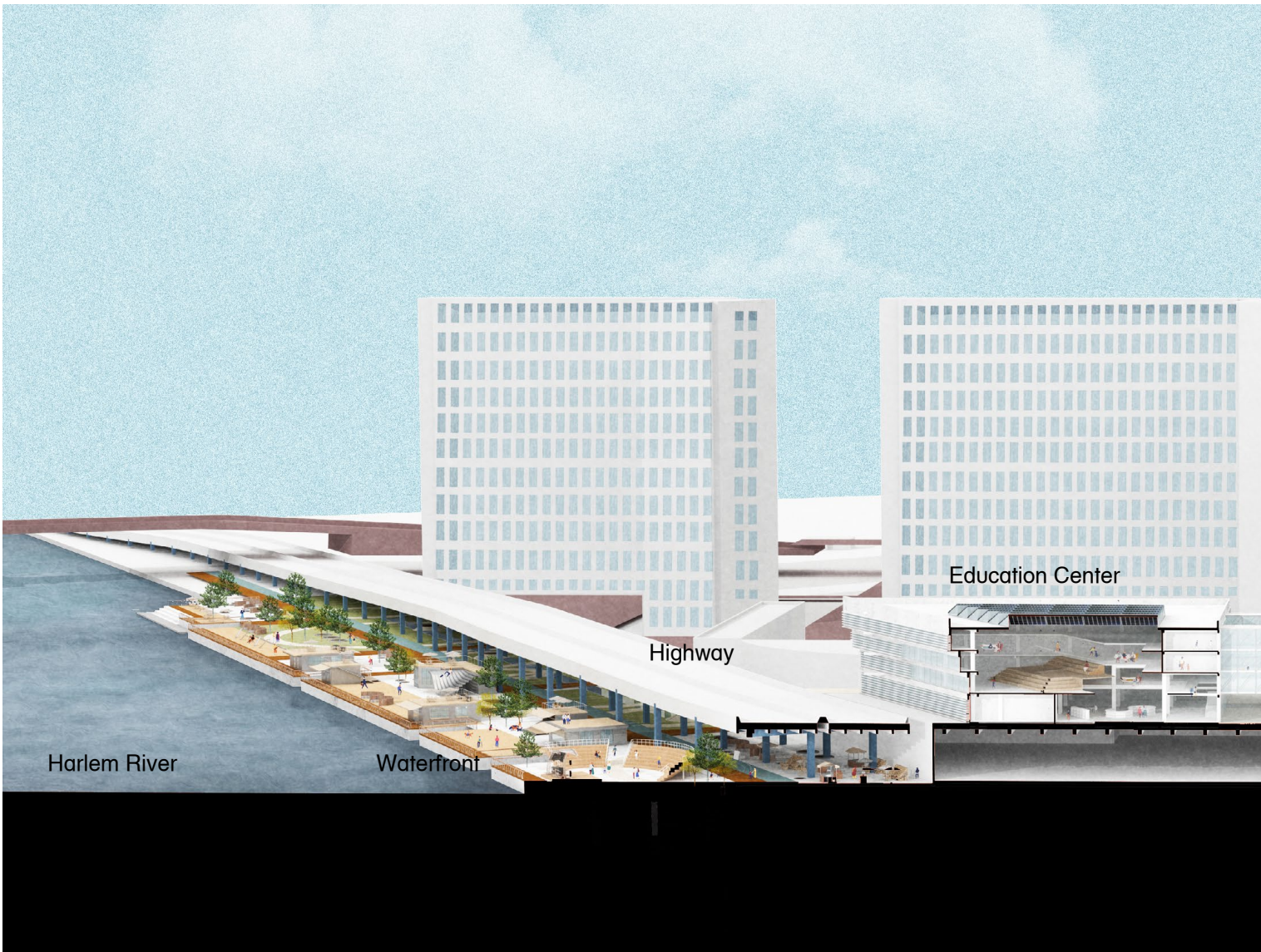





Waterfront Plaza with Differnet Scenarios

Harlem River

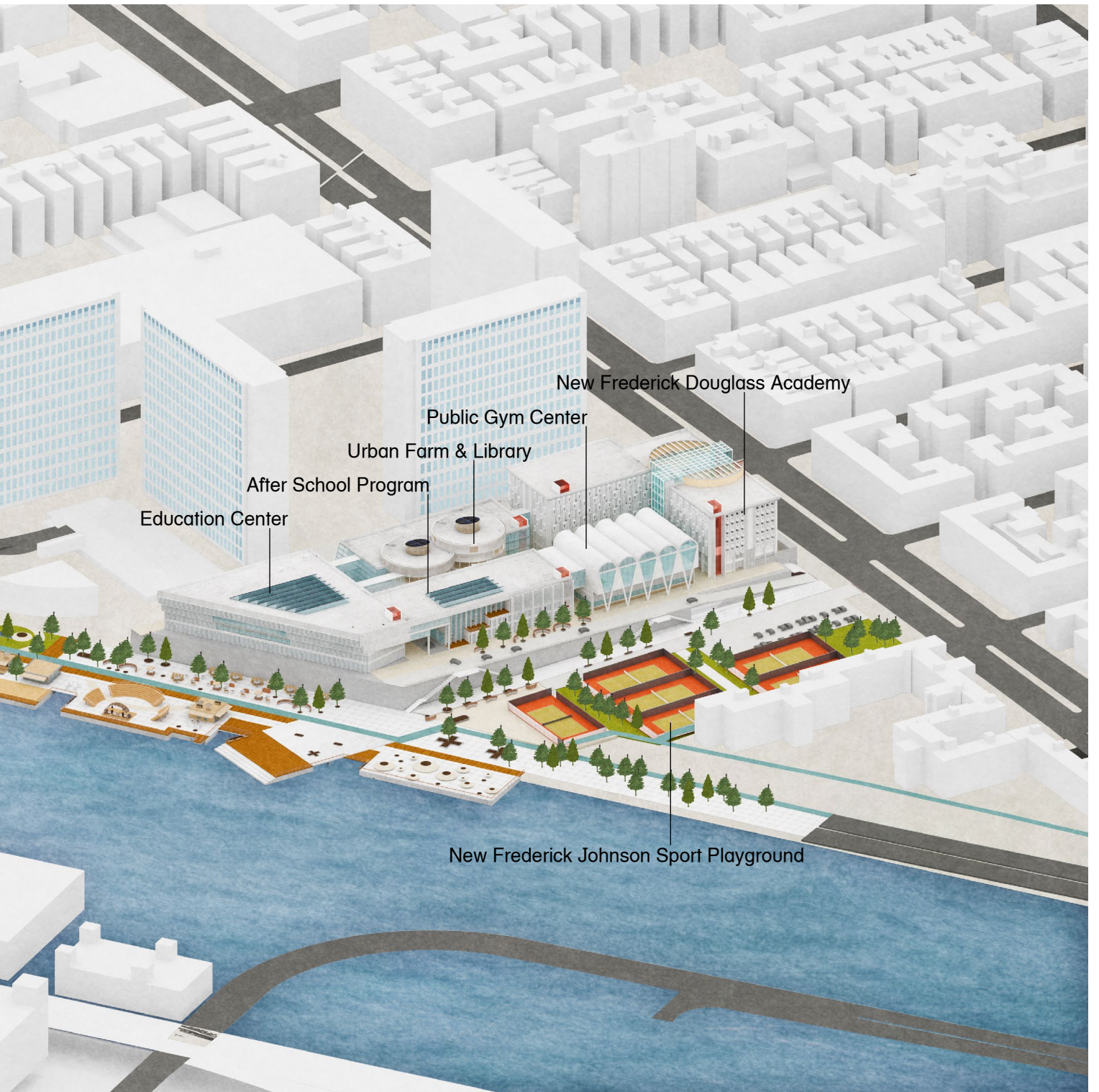

View



Immersive Image-View from Harlem River



Immersive Image-Waterfront Plaza



03 Network (Art & Design Incubator)

Academic Project
Location: Houston, TX
Instructor: Wonne Ickx
Group Work: Yukun Tian, Yunlong Fan
Spring 2022

This is a mixed-use art & design incubator project in Houston. The adaptive reuse project will transform the former Coca-Cola bottling plant to establish new places like artist studios, galleries, classrooms, living rooms, cafe, retails, outdoor courtyards, covered plazas, office buildings, and affordable housing.

This design preserves the original complex's historical and reusable buildings, using linear architectural elements such as linear corridors, canopies and facades to connect the scattered original buildings, urban street networks, make them become a whole, and let the architecture and city generate dialogue.

Inside the building, we give public functions (cafes, retails, etc) at the intersection of those linear circulations, so that the intersections will serve as a public place for social interaction and chance encounters to draw people in and through the whole new complex.

The art incubator will not only become an incubator for artworks, but also provides citizens with a place to live with a cultural atmosphere. As an adaptive reuse project, the new complex will bring a new density of activity and creative life to Houston.

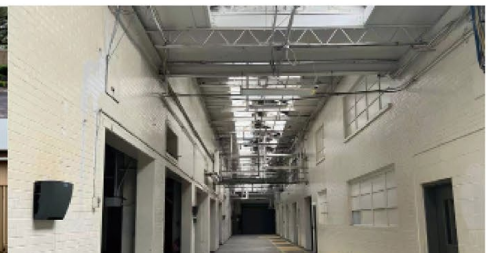
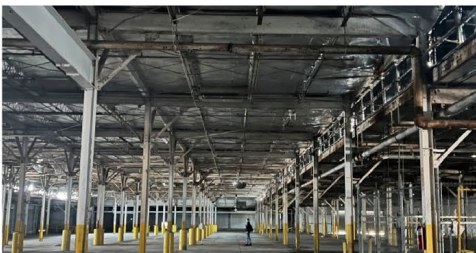
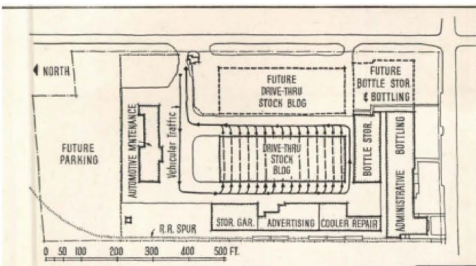
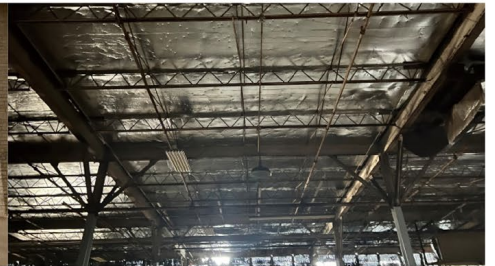
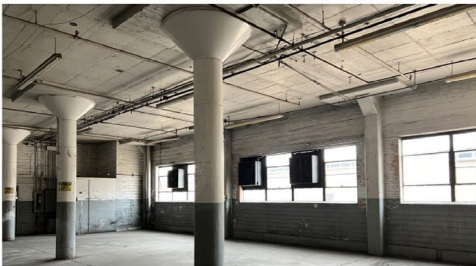
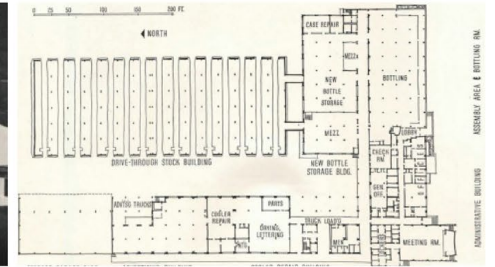
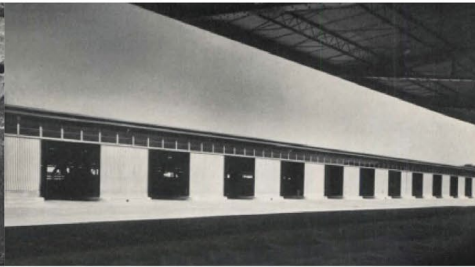
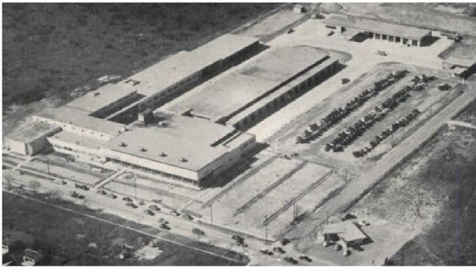

Coca-Cola bottling plant

Maintain Historial

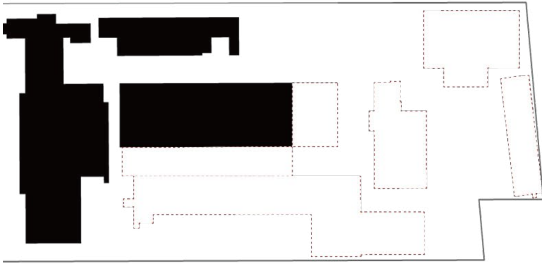

1. Modern Architecture
2. Global well-known brand
3. First Drive-Thru Factory

Organization

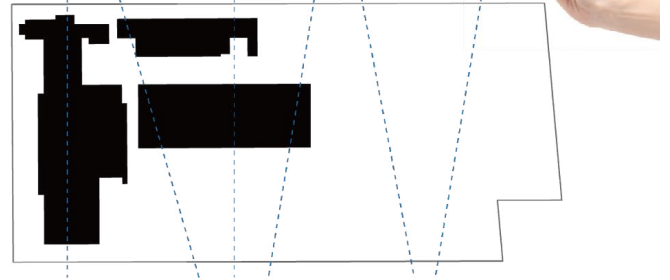

1. Cut
2. Sew

Create Diversity

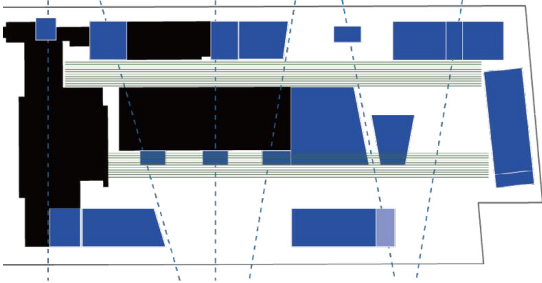

1. Reuse Old Buildings
2. Add New Buildings
3. Add New Architectural Elements

Offer Countless Possibility

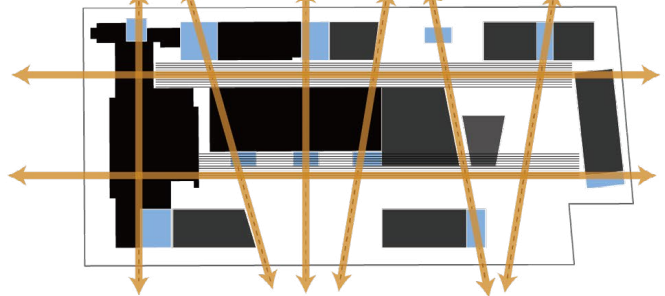

1. Design strip's end points
2. Create new Circulation

Progress Diagram

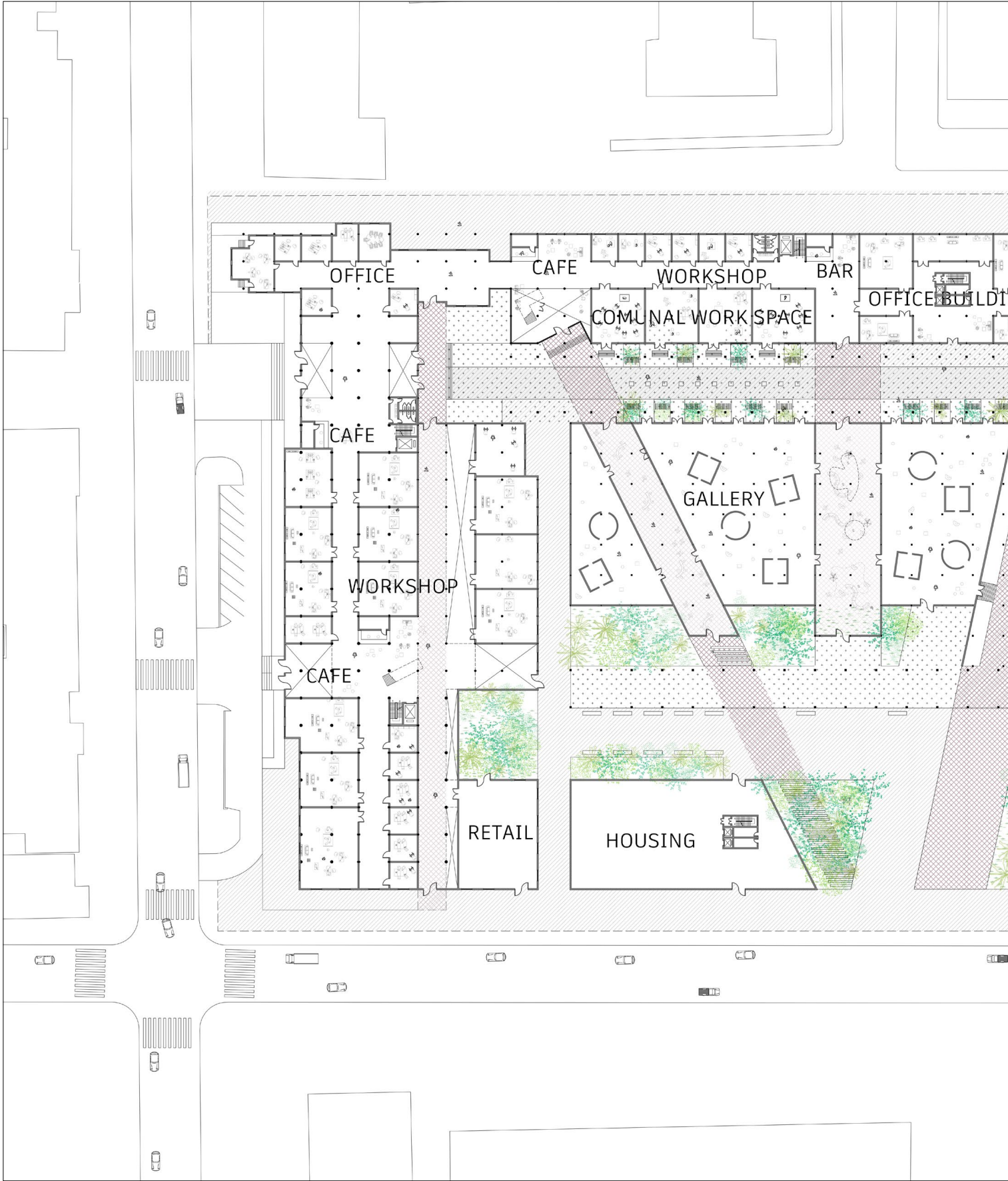



Structure Detail

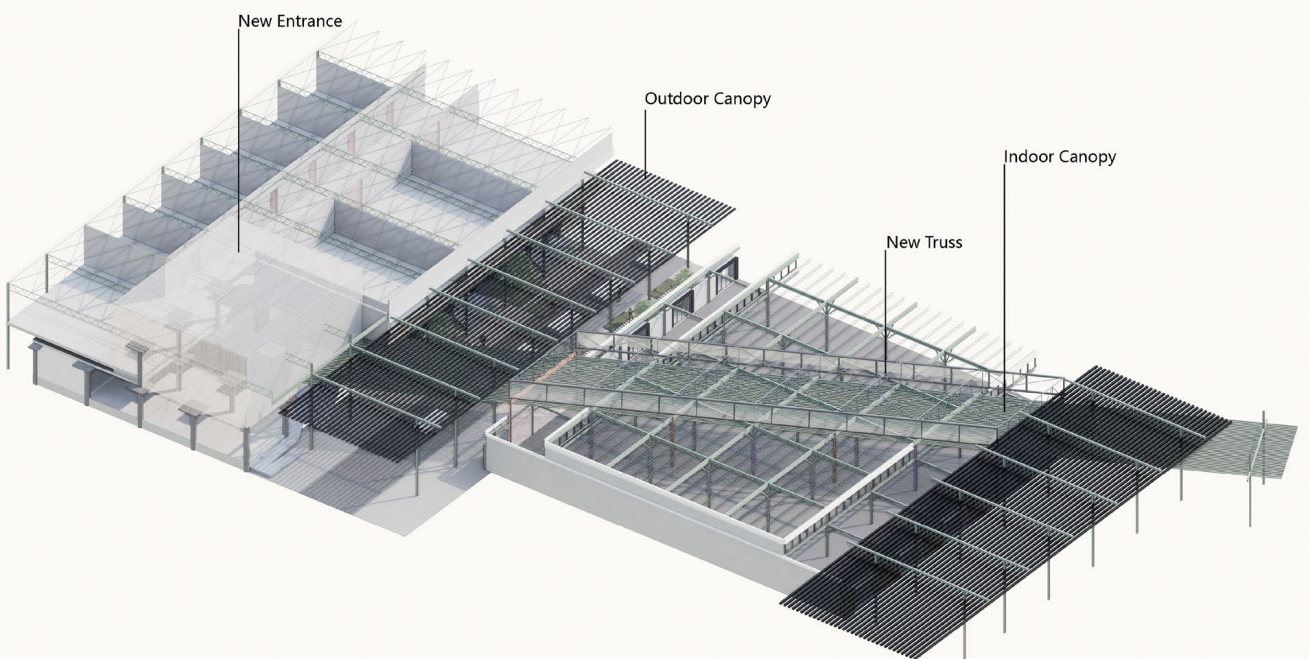
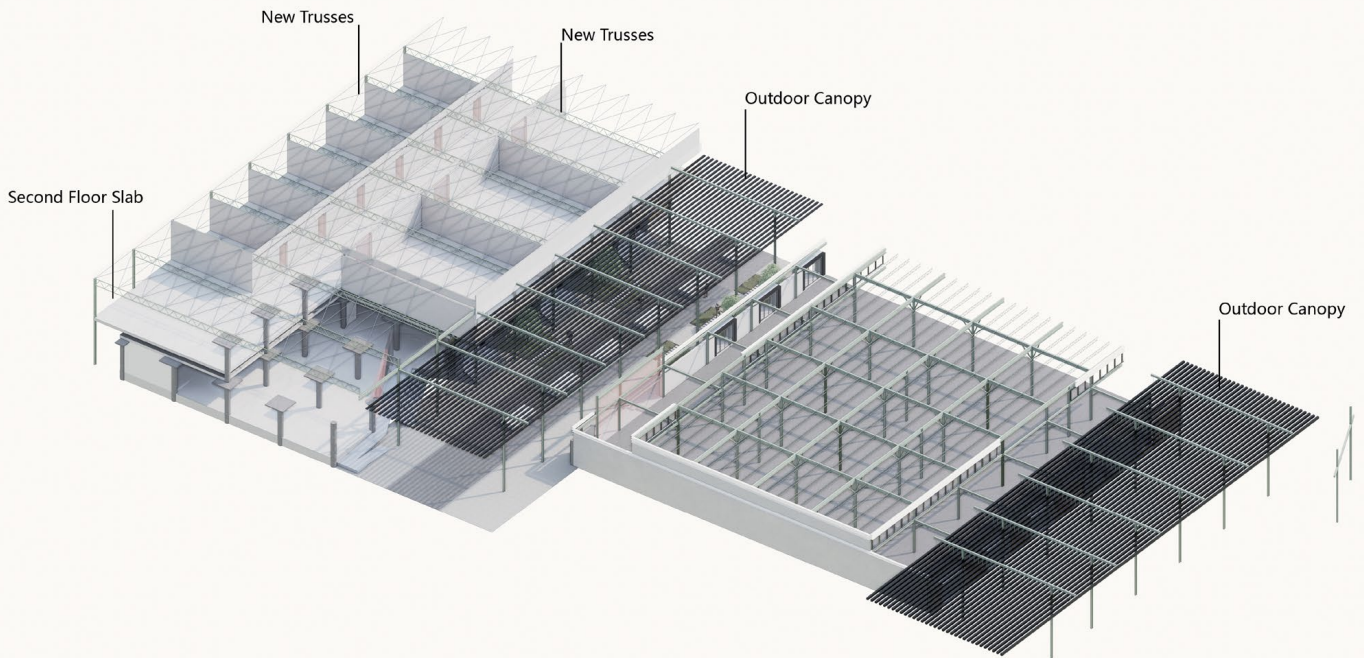
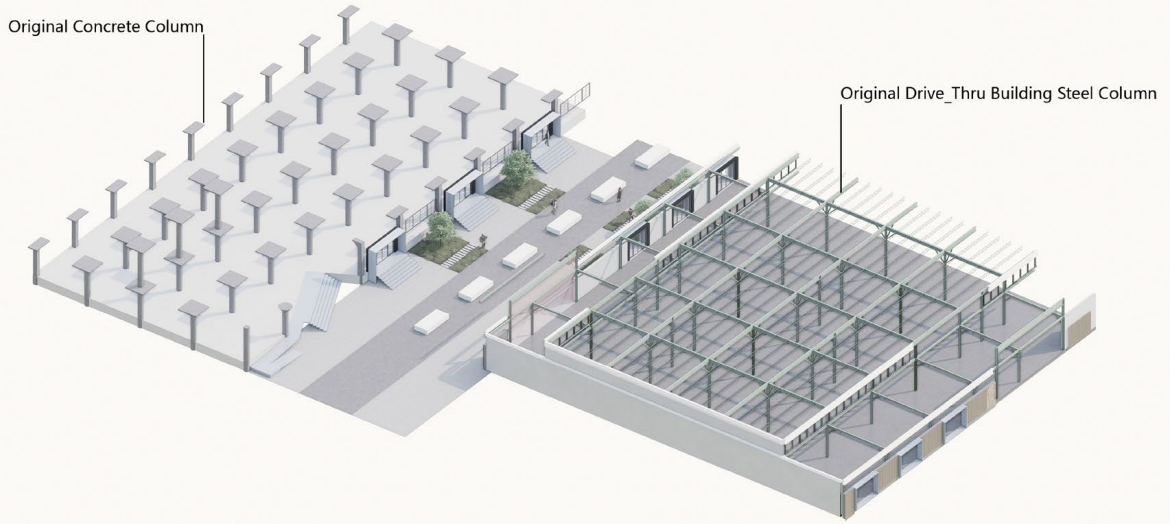

Structure Detail

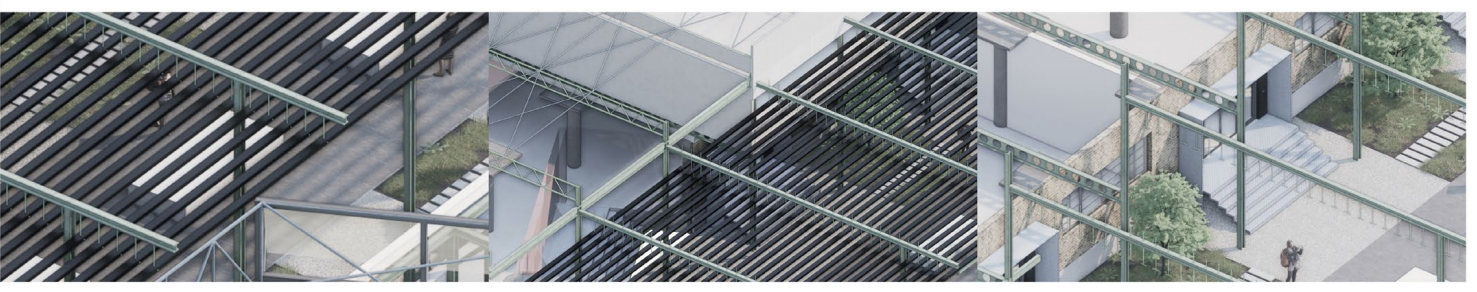
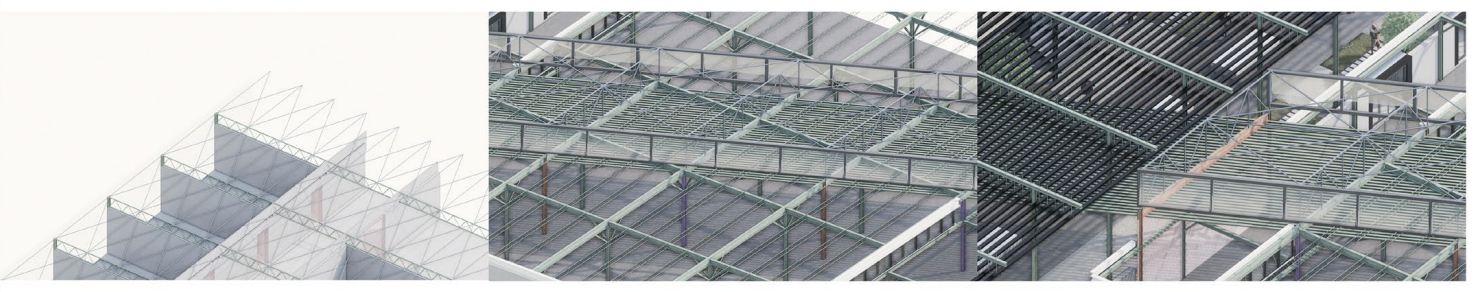
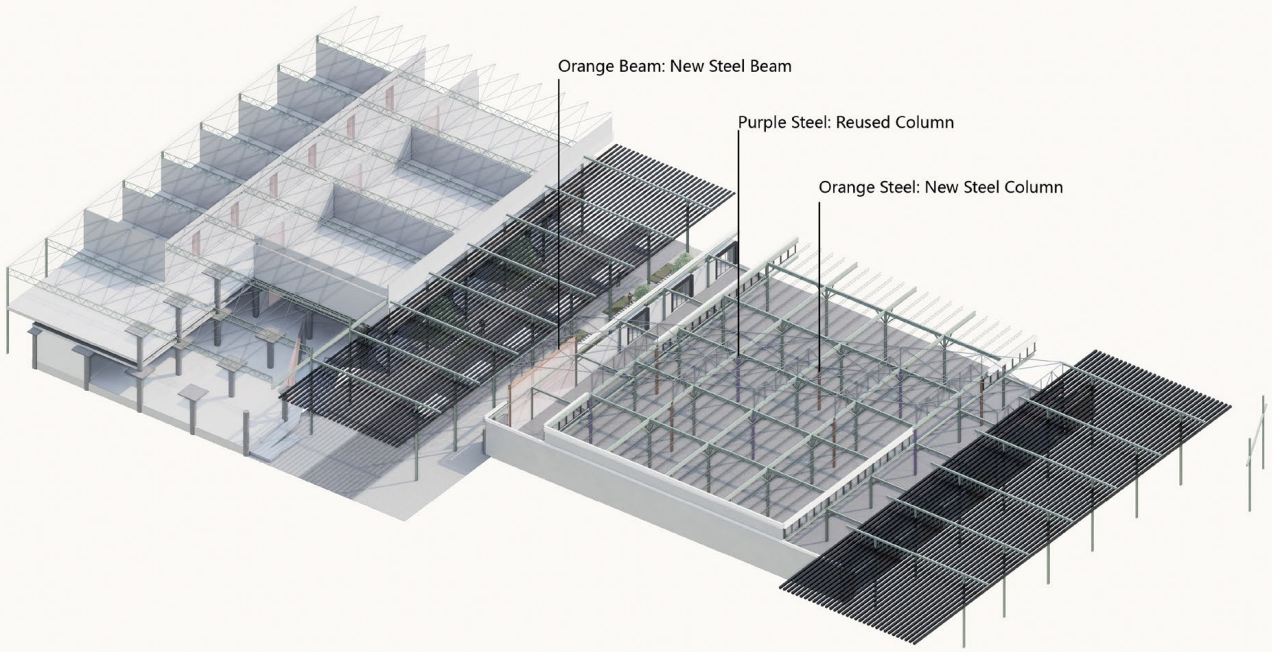
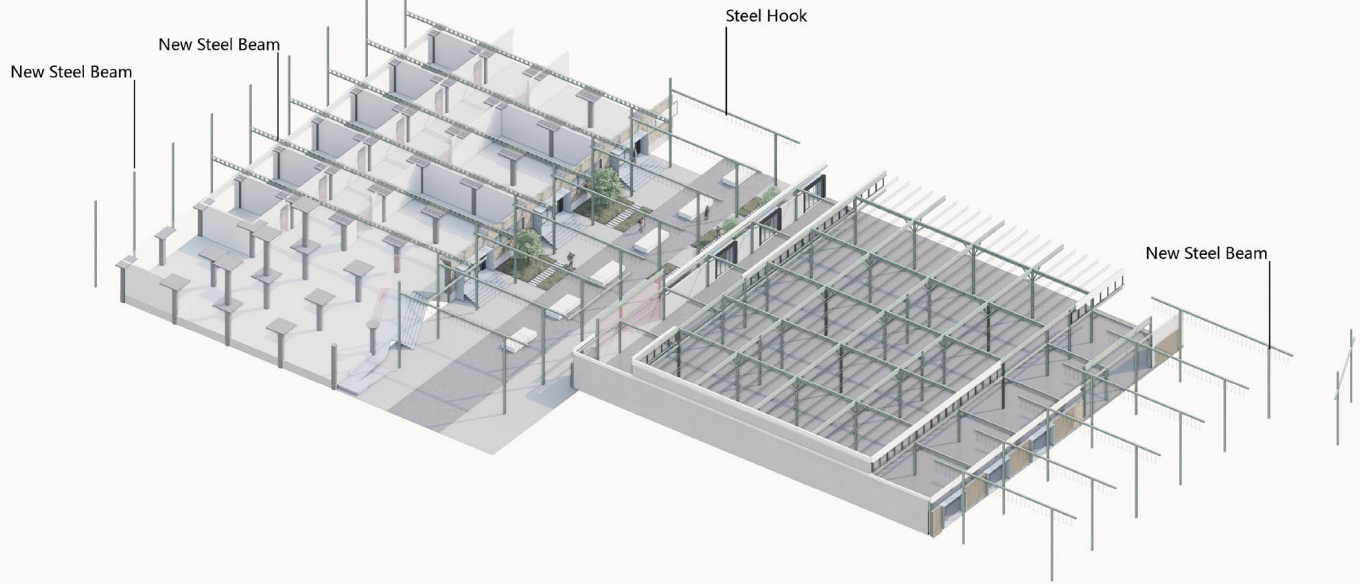



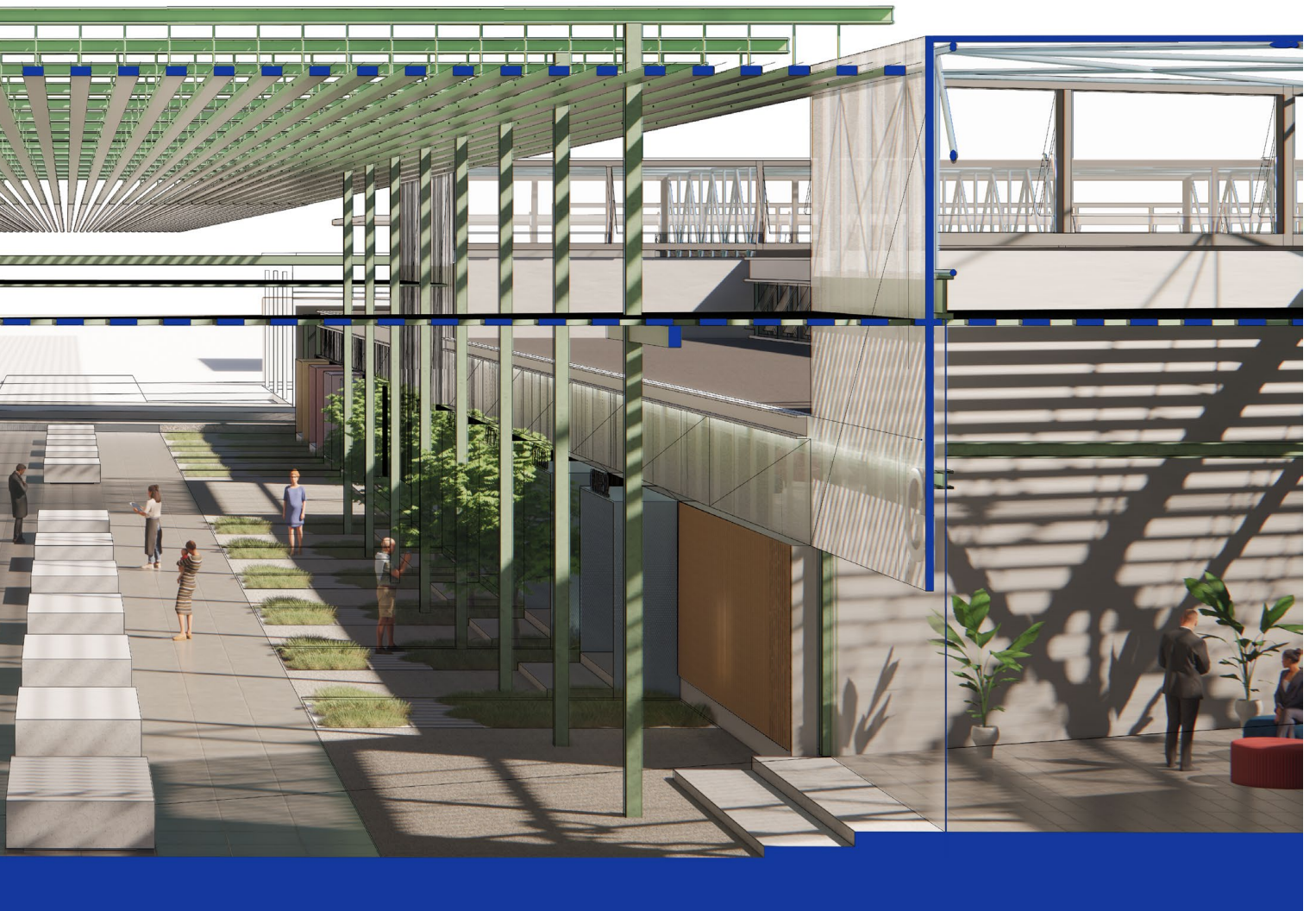

ection

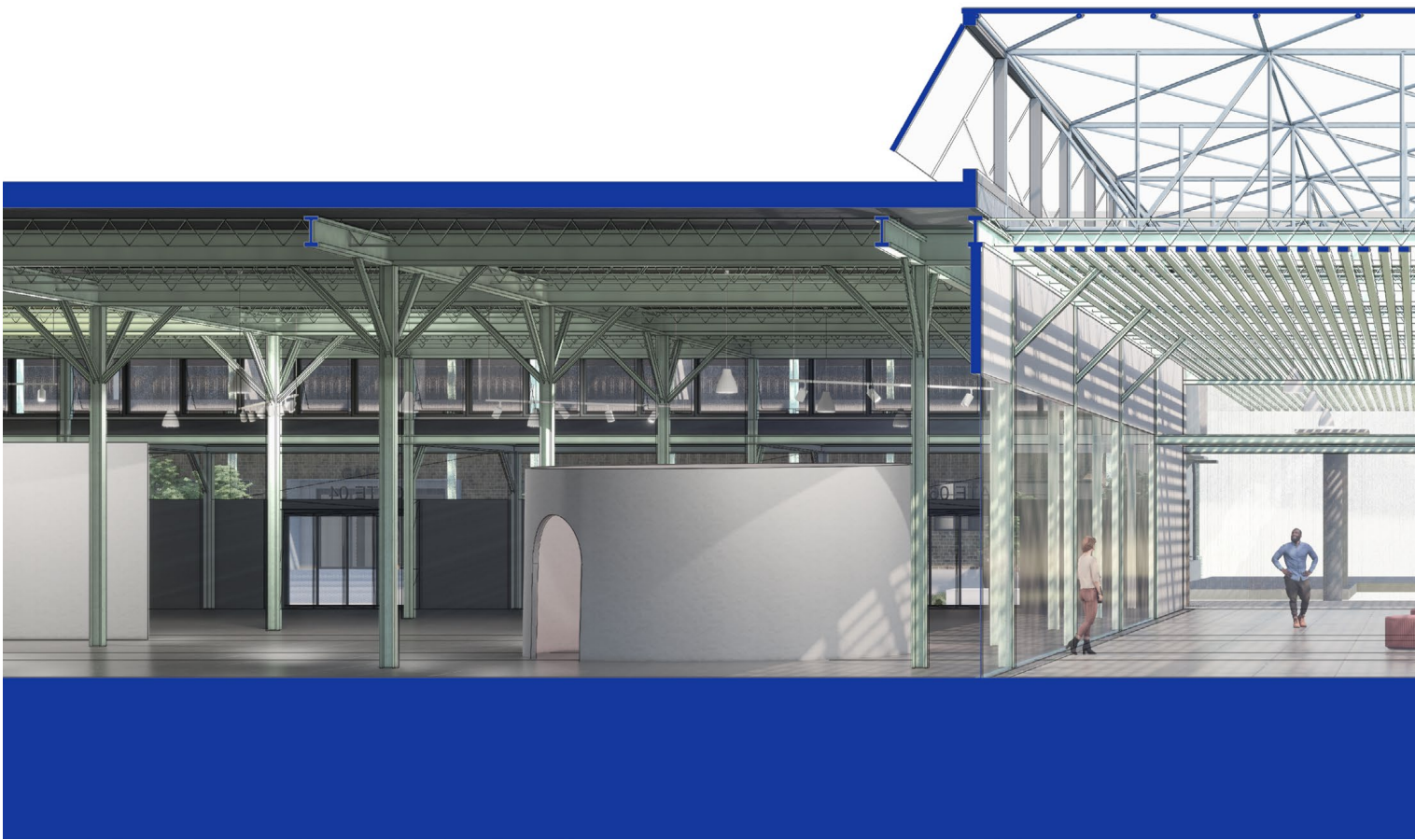



ection



Immersive Image-Corridor(Living Room)



Immersive Image-Outdoor Corridor



Immersive Image-Gallery



Immersive Image-Covered Plaza

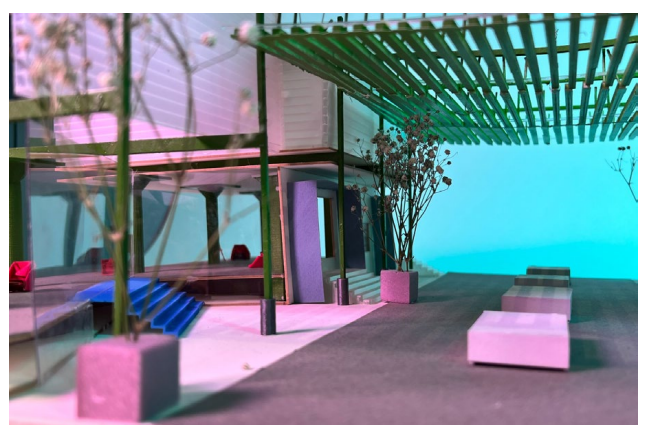
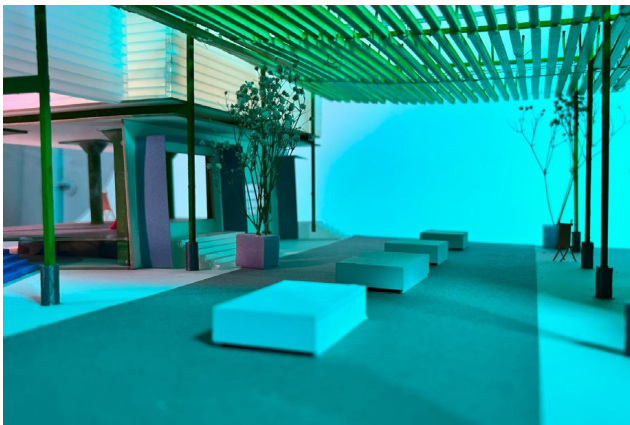

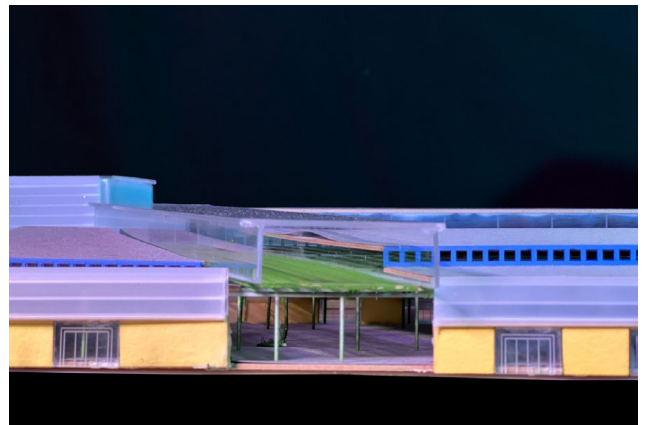
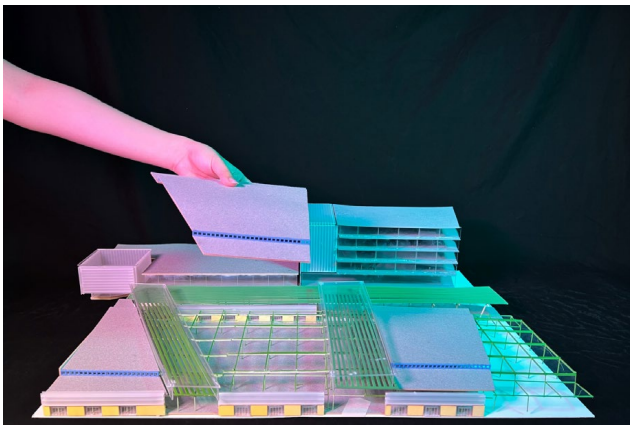
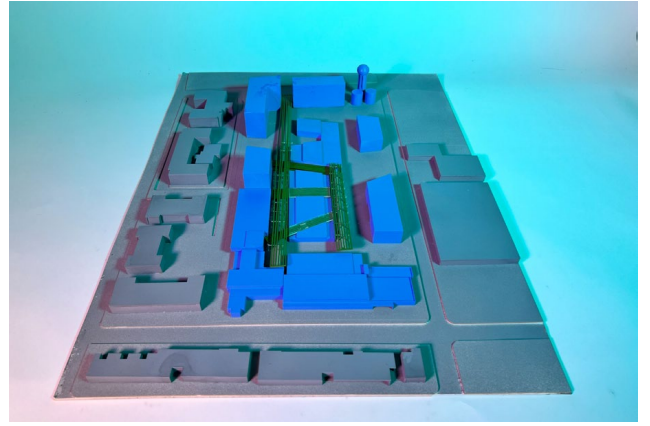
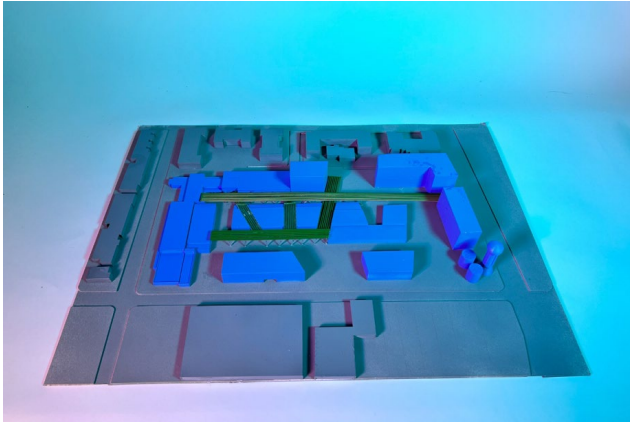



04 GENERATIVE DESIGN_PALACE THEATER VIEW OPTIMIZATION

Academic Project

Location: Place Theater, St Paul, MN, USA

Instructor: Danil Nagy

*Individual Work: Yukun Tian, Yunlong Fan, Shulong Ren, Xueyin Lu, Juno Lee
Fall 2021*

To ensure a good viewing experience is the focus of theater design. We found that the viewing experience depends on the distance between the audience and the stage, the Angle from which the seat deviates from the central axis of the auditorium, the Angle from which the audience needs to turn their heads, and the sight occlusion area. We established an evaluation system for the viewing experience.

Article Website:

<https://medium.com/generative-design-course/theater-view-optimization-fdd3a732035f>

Animation Website:

https://www.youtube.com/watch?v=Xjp9puVq_58

Introduction

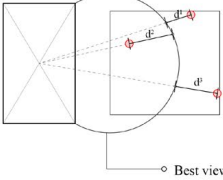
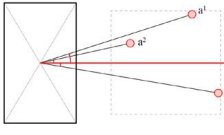
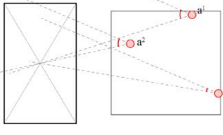
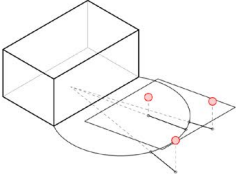
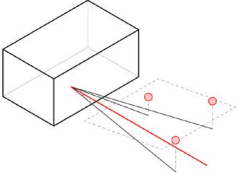
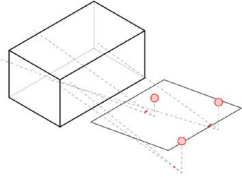
The distance between seat and best veiwing line	Angle at which the seat is positioned away from the center line	Angle of turning head in horizontal direction
 <p> $d^1 = 10.93$ $d^2 = 18.52$ $d^3 = 17.79$ </p> <p>Best viewing line</p>	 <p> $a^1 = 17.73$ $a^2 = 12.30$ $a^3 = 9.55$ </p>	 <p> $a^1 = 40.74$ $a^2 = 35.30$ $a^3 = 13.46$ </p>
		

Evaluation system for the viewing experience-1

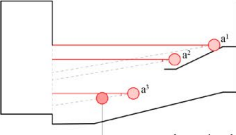
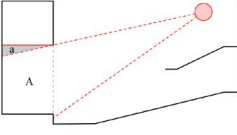
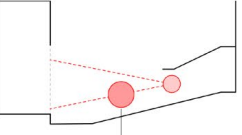
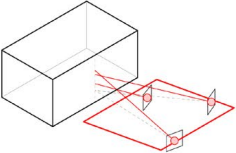
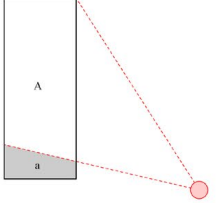
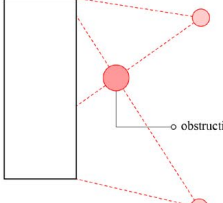
Angle of turning head in vertical direction	Proportion of area obscured by stage frame proportion = (a/A)	Proportion of area obscured by front people's head
 <p> $a^1 = 9.69$ $a^2 = 9.53$ $a^3 = 8.47$ </p> <p>obstruction due to other people</p>	 <p>$P = 8.8\%$</p>	 <p>obstruction</p>
	 <p>$P = 16.7\%$</p>	 <p>obstruction</p>

Evaluation system for the viewing experience-2

The best viewing distance and Angle can turn through the plan of the auditorium and adjust the seat Angle to find the best solution. The deviation from the stage center axis is inevitable. In the general case, sight occlusion caused by the front audience's head. In the traditional theatre design, C value is the parameter that evaluates sight occlusion. By adjusting the stage slope, seat spacing and stage height, the architect ensured sufficient C value to avoid obstacles.

However, in some existing theatres, the sight occlusion has always existed due to space limitation and unreasonable seat arrangement. We tried to minimize sight occlusion area by optimizing seat position through Genetic Algorithm in the existing theatres without changing the original building structure.

Methodology

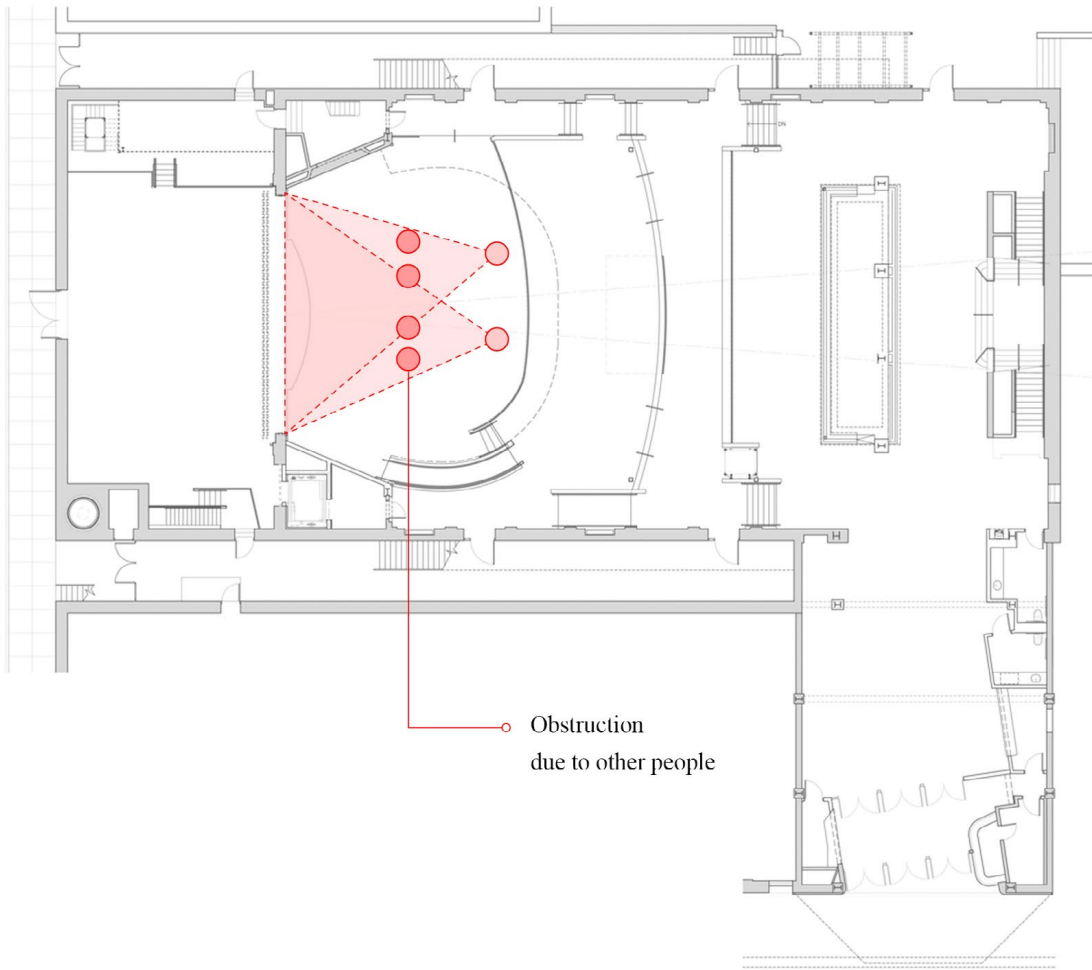

First floor plan

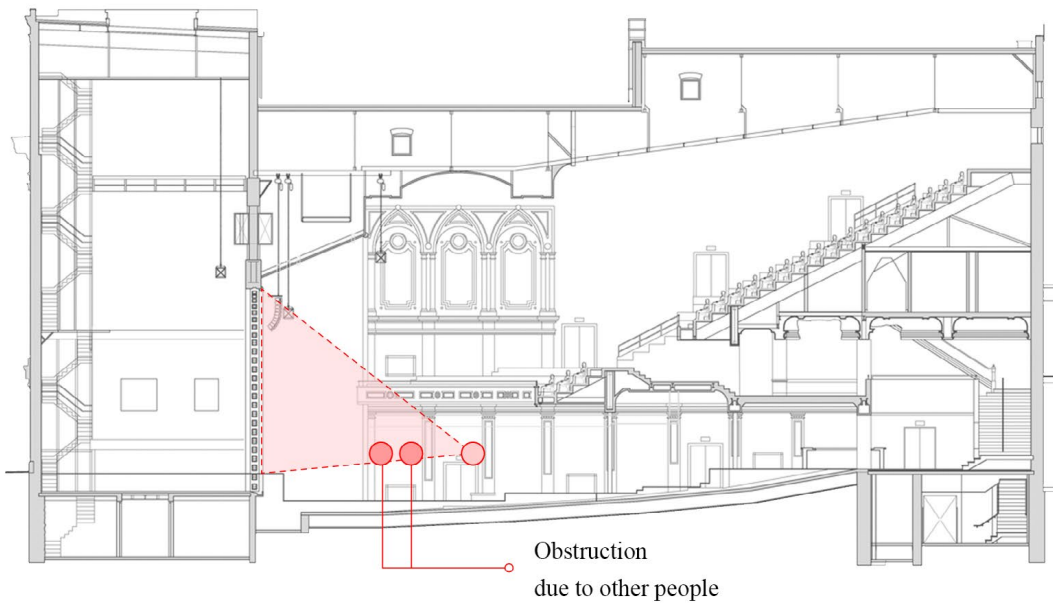

Section

Problem Diagram

Methodology

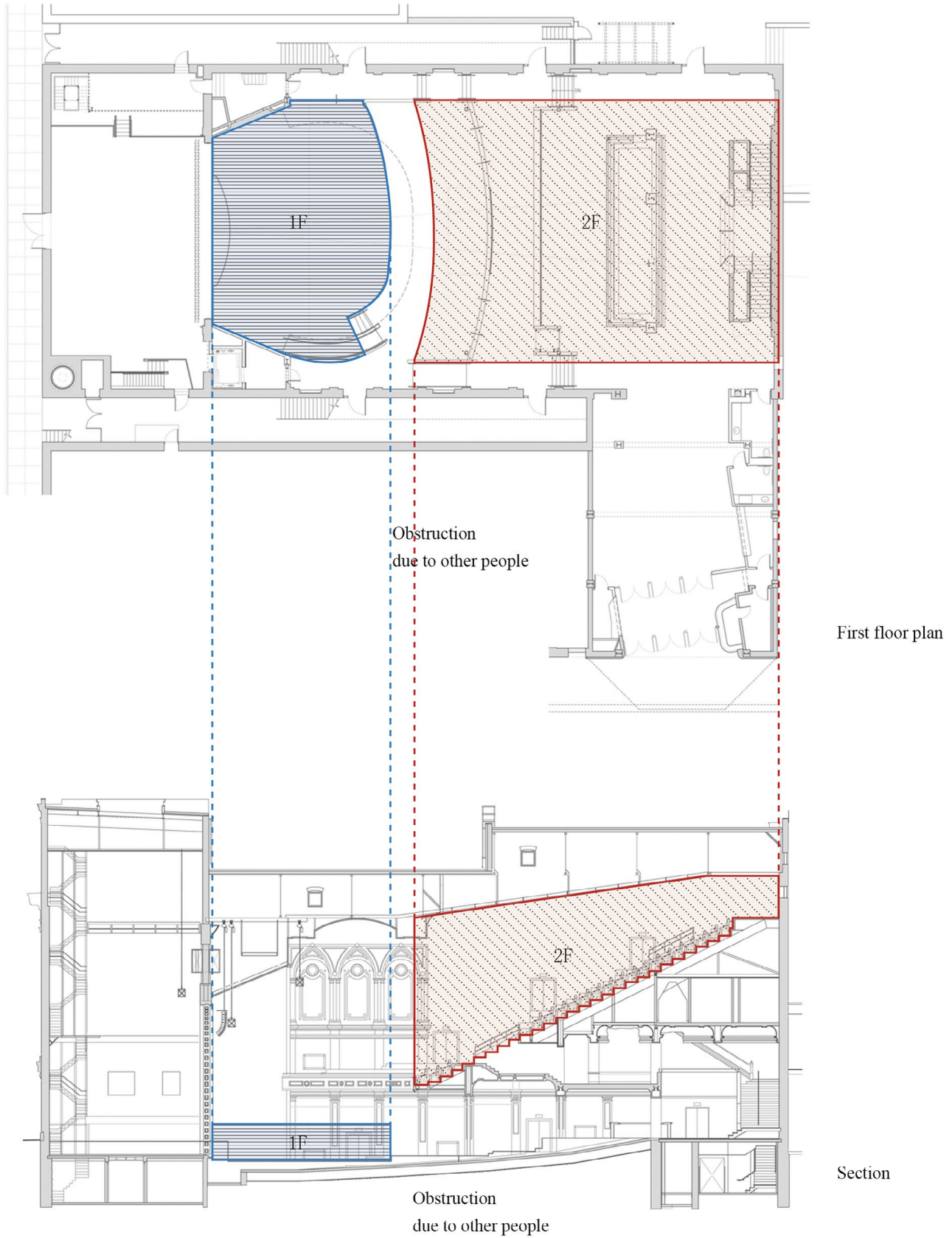

Proposal 1 — Blue Proposal 2 — Red

We chose Palace Theater in Saint Paul as our optimization target. The century-old Palace Theatre was originally operated as a vaudeville theatre in 1916. The first floor of this theater is completely horizontal. For flexibility, there are no fixed seats in the audience area. Due to the limited space on the upper floor, the slope of the auditorium does not meet the C value, which will block the view.

Algorithm

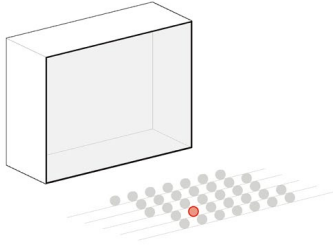

How to quantify the sight occlusion of a seat ?

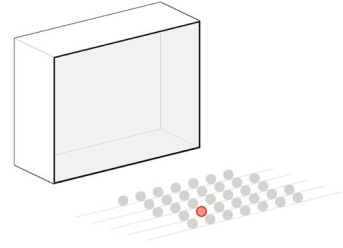

How to quantify the sight occlusion of a seat ?

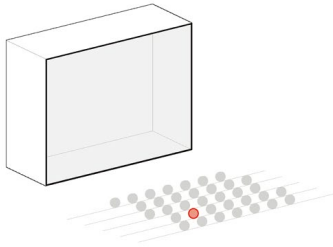

How to quantify the sight occlusion of a seat ?

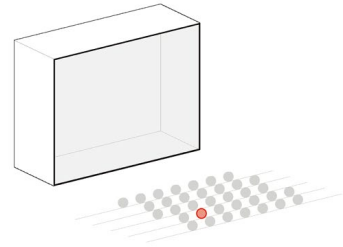

How to quantify the sight occlusion of a seat ?

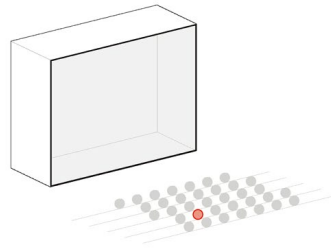

How to quantify the sight occlusion of a seat ?

The algorithmic parts of both proposals are essentially the same:

First, we draw a cone with the eyes of a random viewer as vertex and the head of all other audiences as base. After extending the length of the generatrices, we selected the cones that have intersected area with the screening. We found that those who are far from this audience have little influence. So in order to simplify the calculation, we only calculate cones in a small range. We also used collision detection to prevent any two seats from being too close or out of bounds.

For the first floor, we input the boundary curve of the audience area and the XY coordinates of all seats to calculate the occlusion area of each audience by the above method, and output the average value.

For the upper floor, we input the position curve of each row and the number of seats in each row, calculate the occlusion area of each audience by the above method, and output the average value.

Proposal I-Optimization of First Floor



Proposal I Results

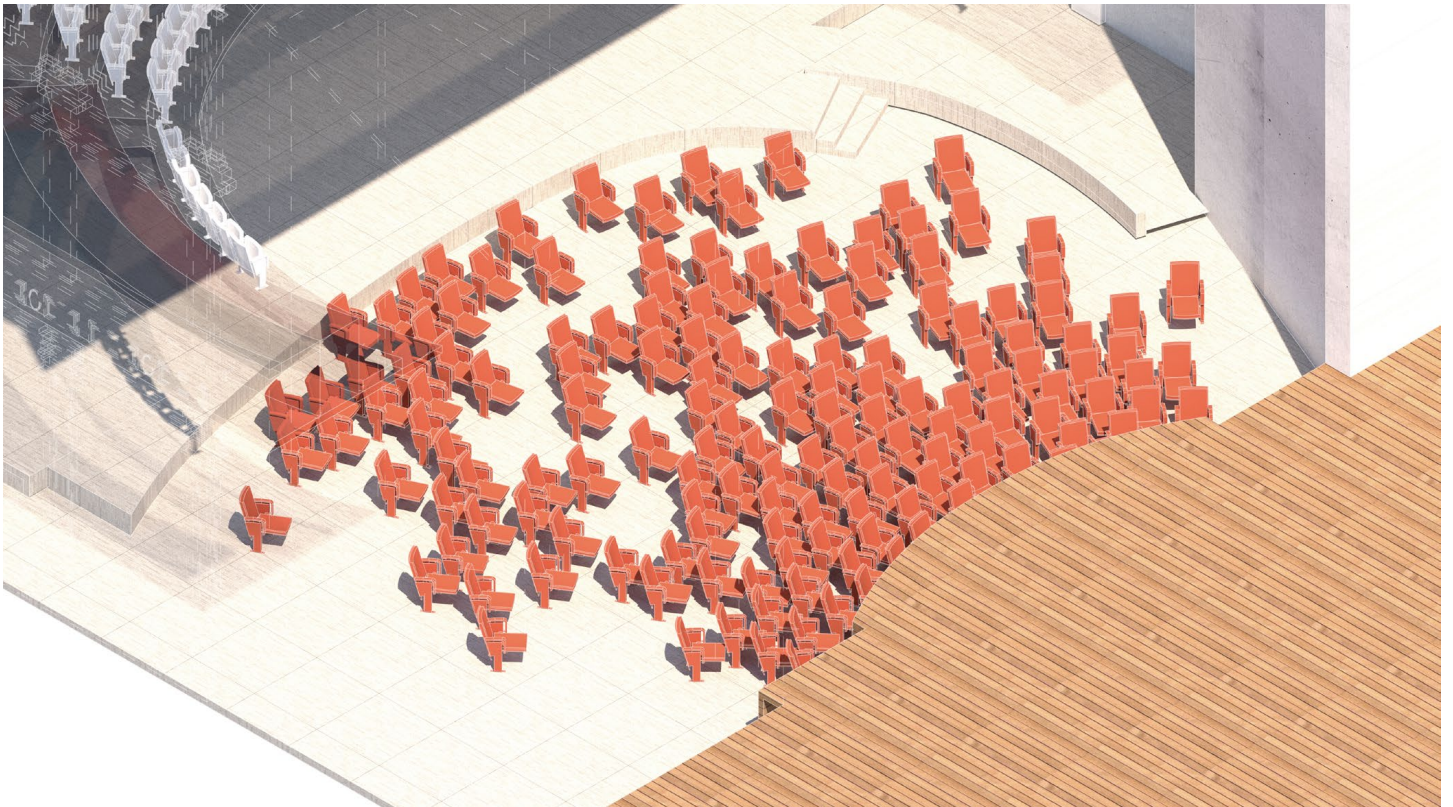

For the first floor, we put forward a more radical design strategy. Seats are randomly generated in this area. We then calculate the average sight occlusion area of each choice, and optimize the whole area by Genetic Algorithm. Flexible arrangement can fit different types of performance.

The trend of the optimal result is that the seats are concentrated in the front, and the front follows the principle of staggered arrangement. The back row is scattered as far as possible, and the distance between the front and rear rows is enlarged, which will reduce the shielding of the front row from the back row.

Proposal 2-Optimization of Second Floor

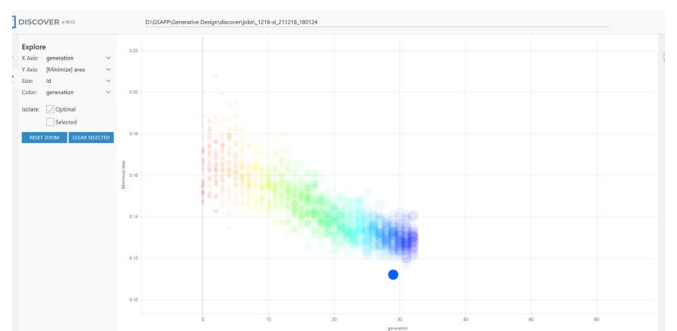
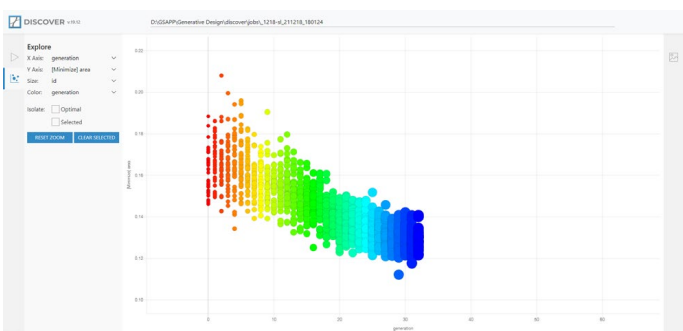
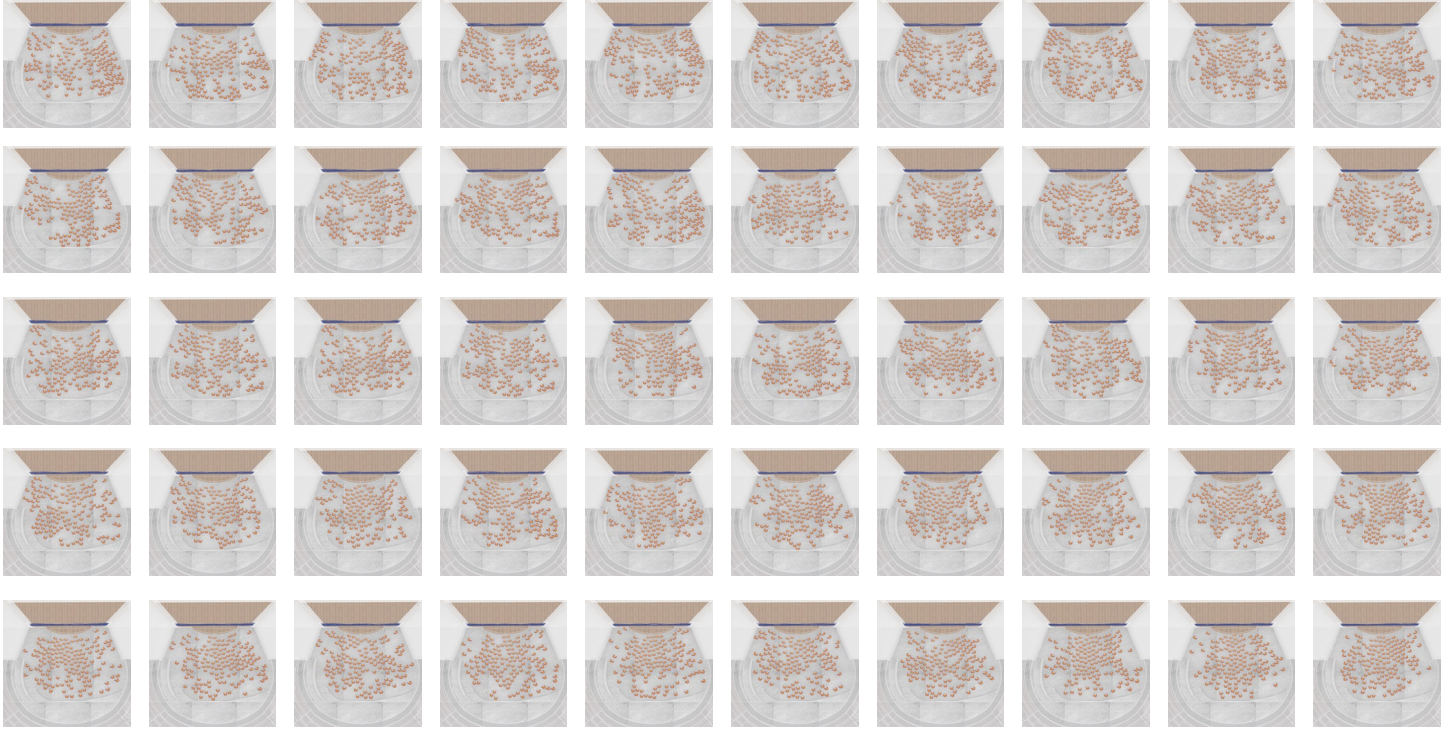

Proposal 2 Results

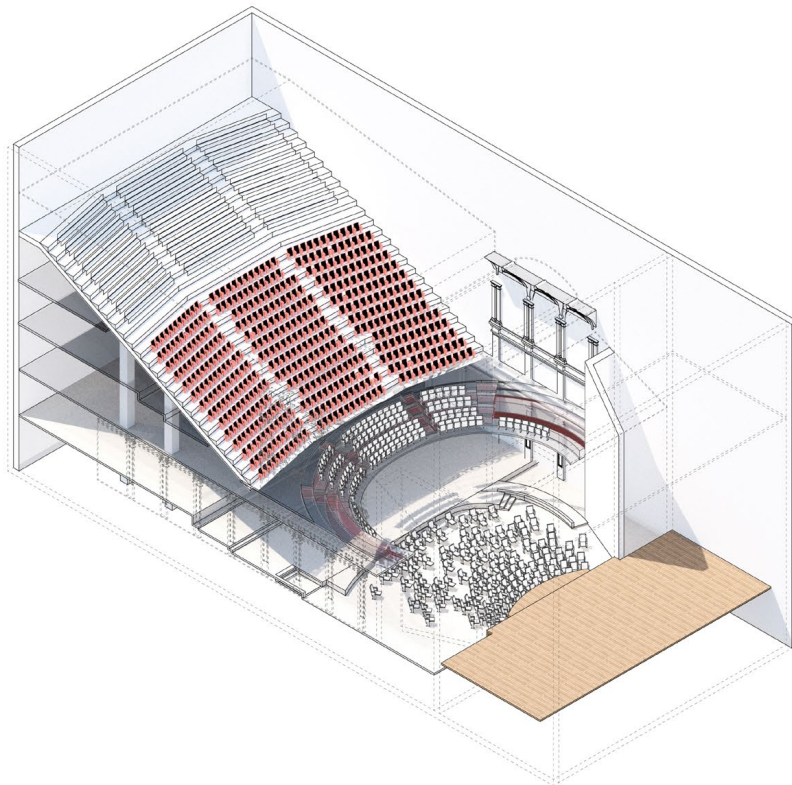
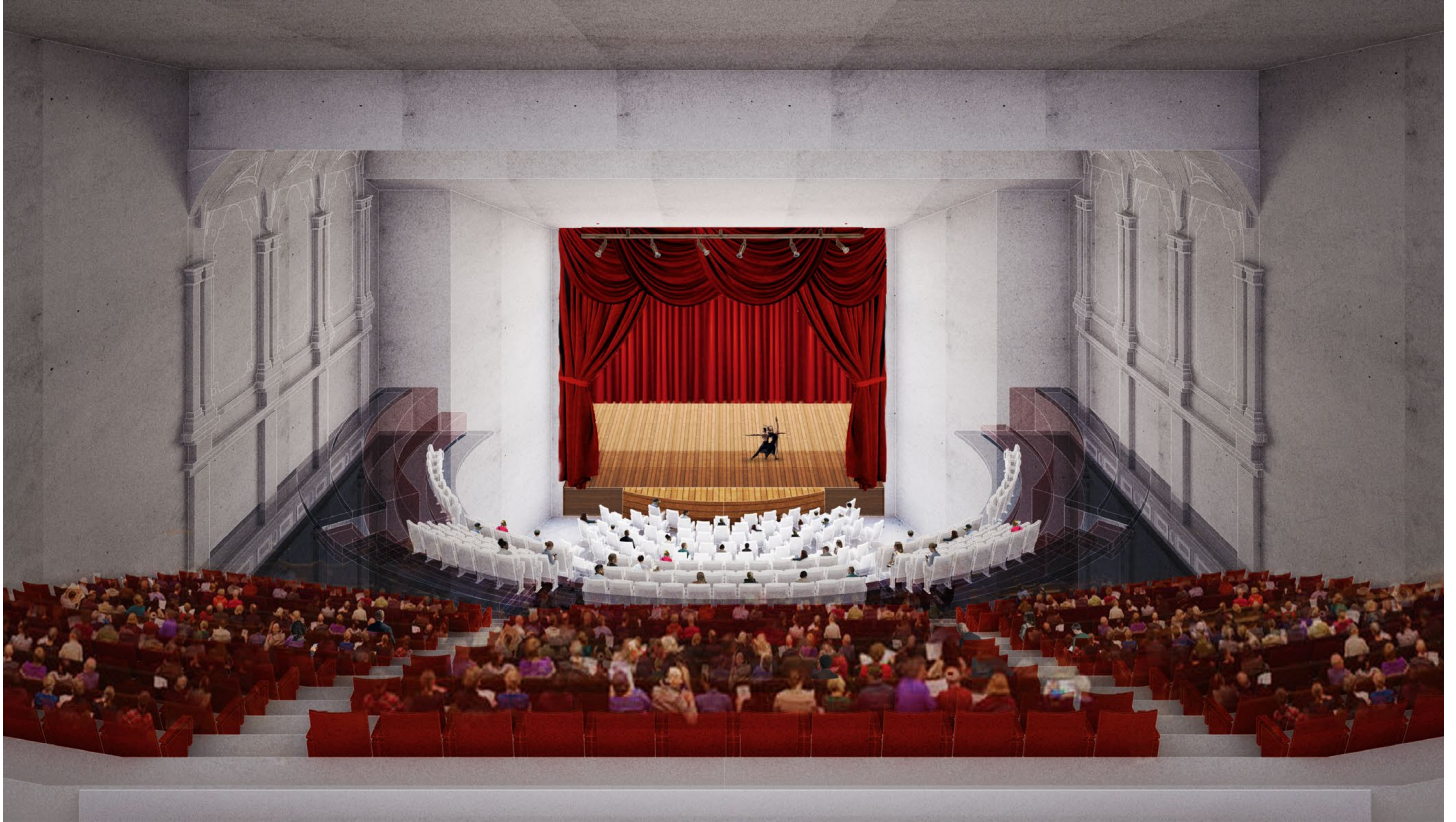

For the upper floor, we kept the traditional arrangement of the auditorium — arranged in rows — and the number of seats. We used the original structure of the auditorium, and only adjusted the left and right spacing of each seat to reduce the shielding area of the audience.

The trend of the optimal results is that the farther away from the stage, the less the seat in the rear row is staggered than the seat in the front row. Conversely, the more directly facing the stage, the greater the staggered distance of the rear row (up to 50% of the width of the seat). This tendency gives everyone the best view.

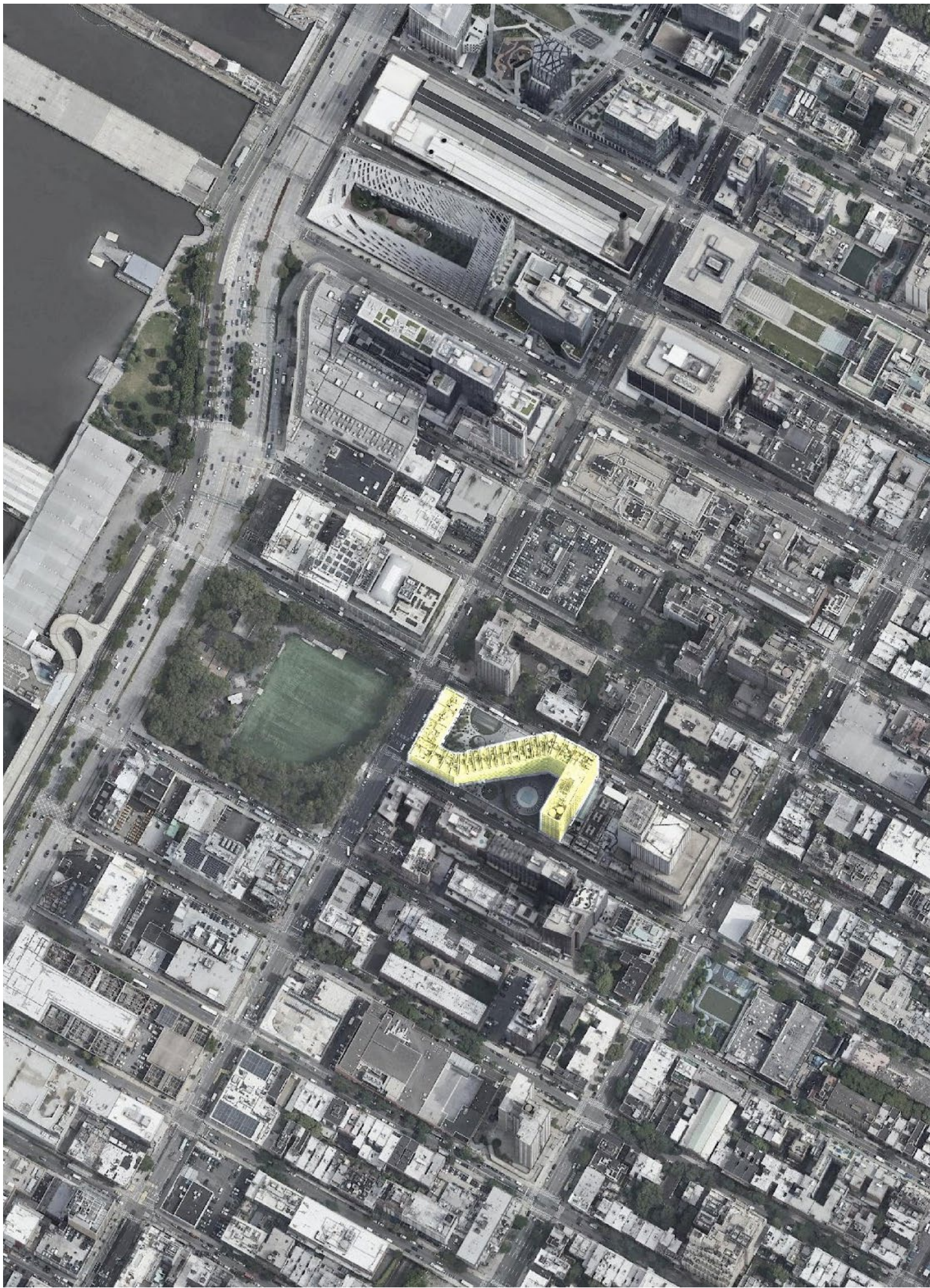

05 RETHINKING BIM_DAYLIGHT AND 'VALUE' OPTIMIZATION

Academic Project
Location: Mercedes House, NY
Instructor: Joe Brennan
Group Work: Yukun Tian, Yunlong Fan, Yingjie Liu, Ece Cetin
Spring 2022

Inspired by the original intent of the Mercedes House, we wanted to push the ambition further. We wanted to maximize the number of units that have continuous sunlight access throughout the day. We were inspired by the correlation between the optimized access to daylight that massing provides and the increased value of the units through an improved user experience.

To achieve our goal to optimize the massing for the maximum amount of units with more than 5 hours of access to daylight, we formed this workflow. In the preliminary research, we used weather information and context building information to find the drawbacks of the original building. With this analysis, we found that introducing voids into the massing and placing these units back on the top of the massing allows for optimal access to daylight for more units. Our massing tests here are different iterations of cutting out voids and placing them back on the building massing. This way we are preserving the number of units but simply repositioning their arrangement for optimal massing conditions in relation to daylight. And finally, as we are architectural students so we do more design parts for the building and plaza.

Animation Website:
https://www.youtube.com/watch?v=riJ_uQS3j9s&t=3s

Preliminary Analysis

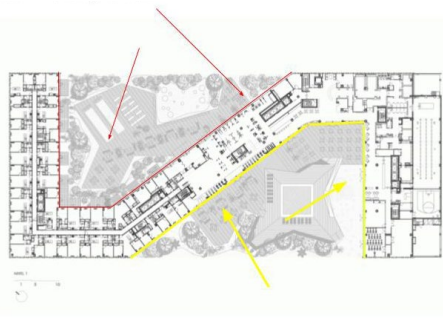

Type: Mixed Use

Project Scope: New Construction

Year Completed: 2012

1.3 million square feet of commercial and residential programs.

Commercial below, 27 floors of housing above

The residential form creates a total of 865 units

The building's mirrored structure introduces the creation of two courtyards—a sun-bathed pool garden to the south and a shaded activities court to the north.

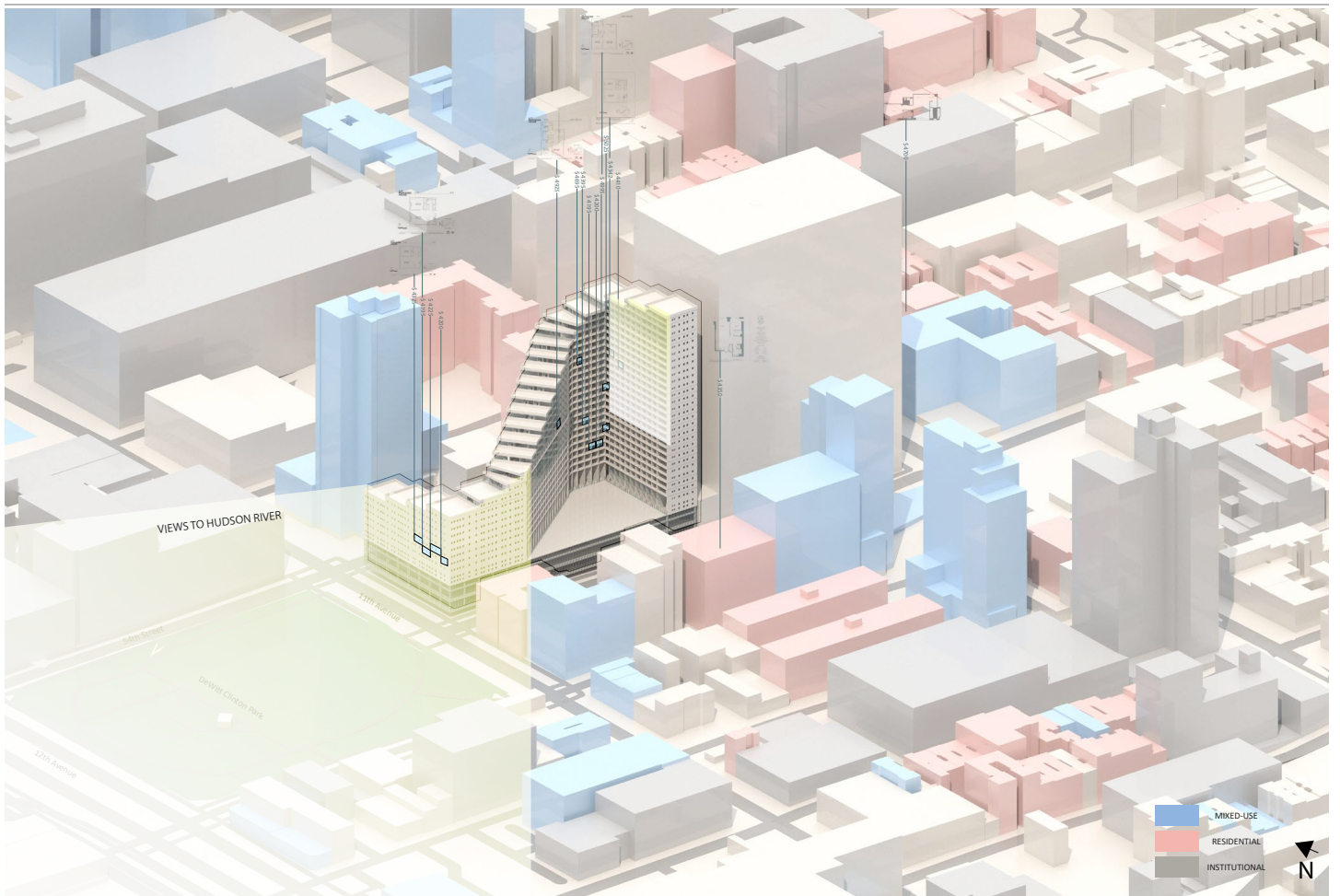

Through our analysis and intervention we are aiming to maximize the number of units with improved daylight access. Given the direct correlation between demand and cost, we argue that this will allow a better distribution of rent, a higher availability of units with better daylight conditions and therefore an improved mediation between the architecture and the market.

Daylight Analysis

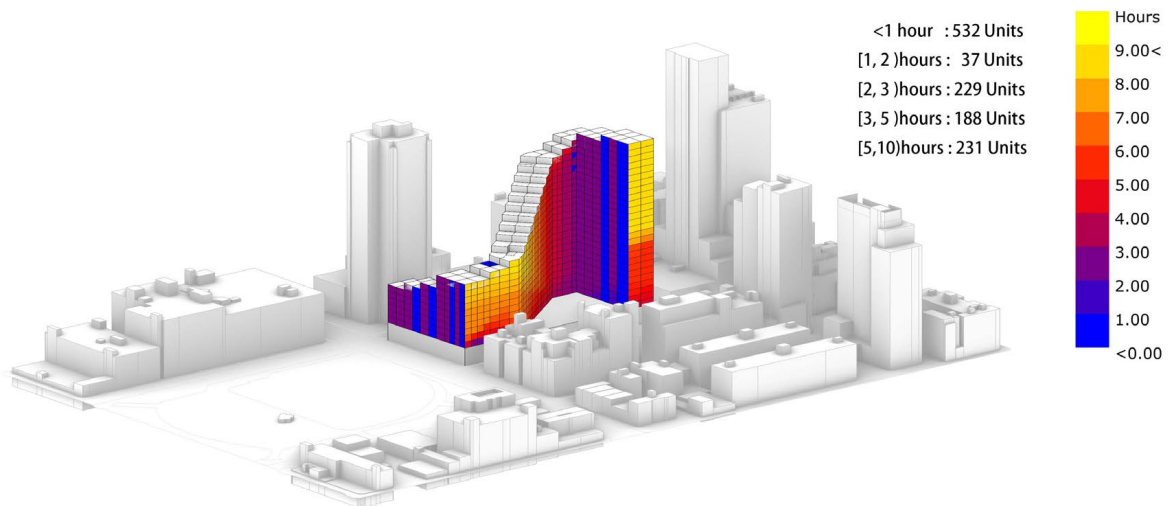
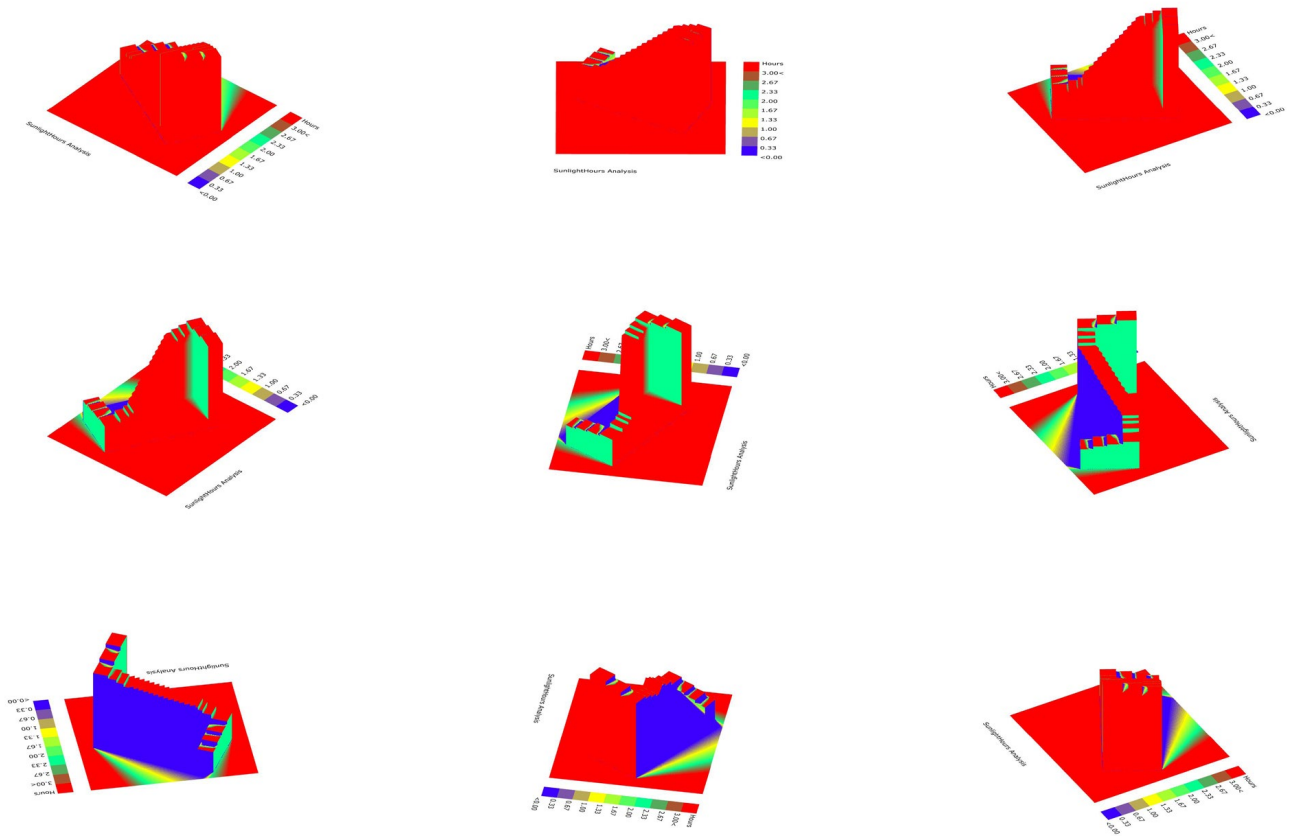

We analyze the daily lighting of each unit of the original building and represent the analyzed daily sunshine time in different colors. For example, the red part represents that the units there receive more than 3 hours of daily lighting time, and the blue part represents where units receive less than 1 hour of light per day. We have come to the conclusion that the daily lighting time of the units of the original building varies greatly, and some units even get less than 1 hour of lighting time.

Daylight Analysis



Daylight Analysis

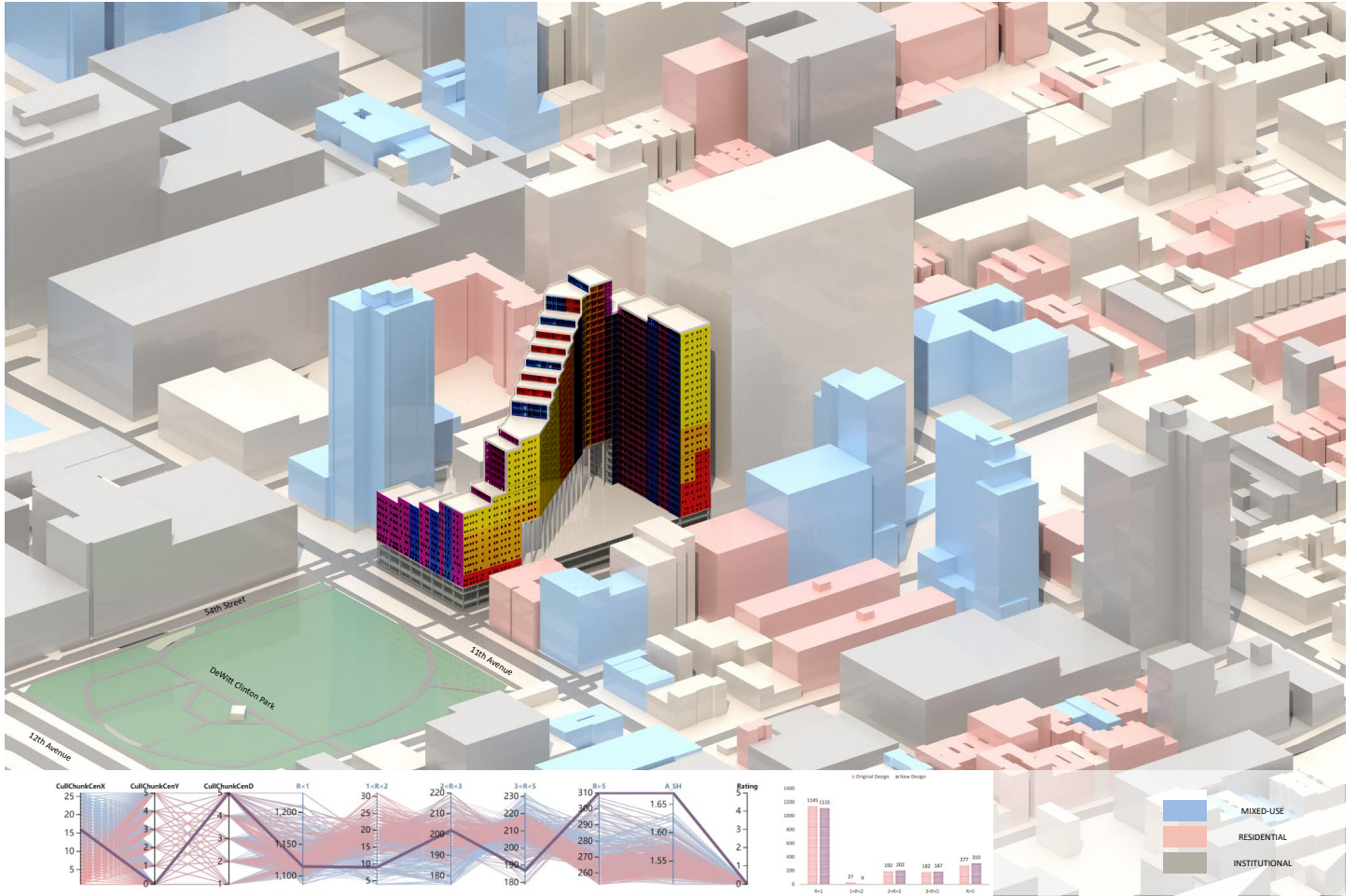

Result of Optimization

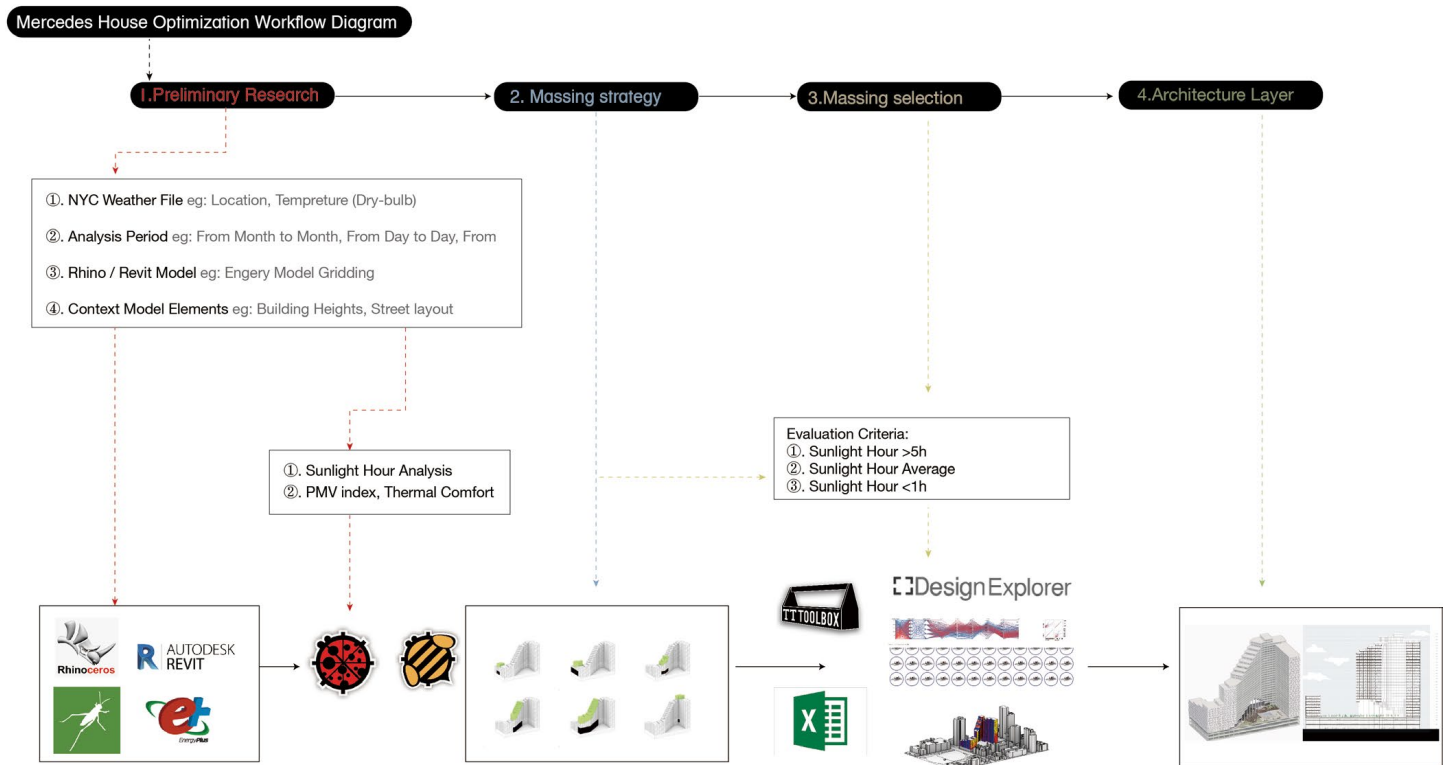

Workflow Diagram

Results

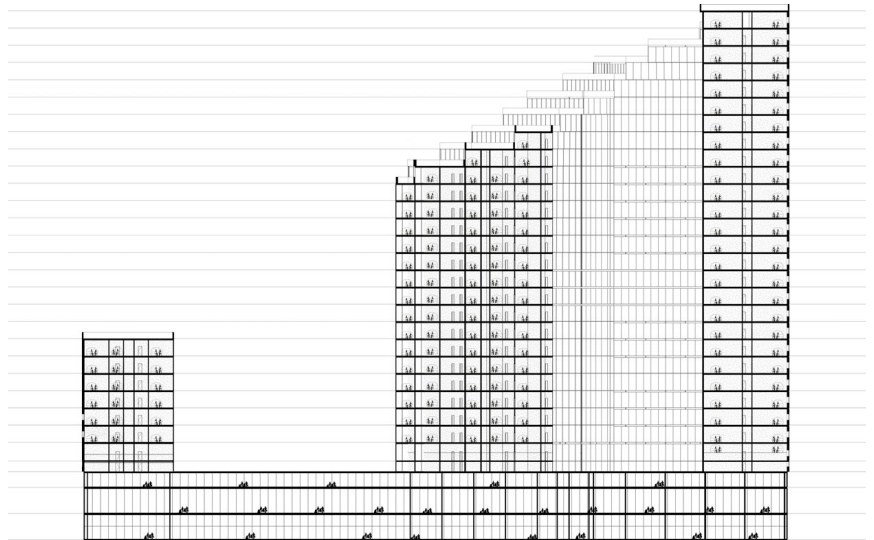
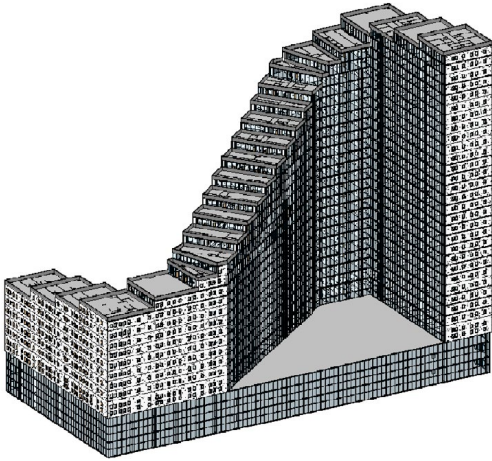

Original Building



Optimized Axon Response

Results

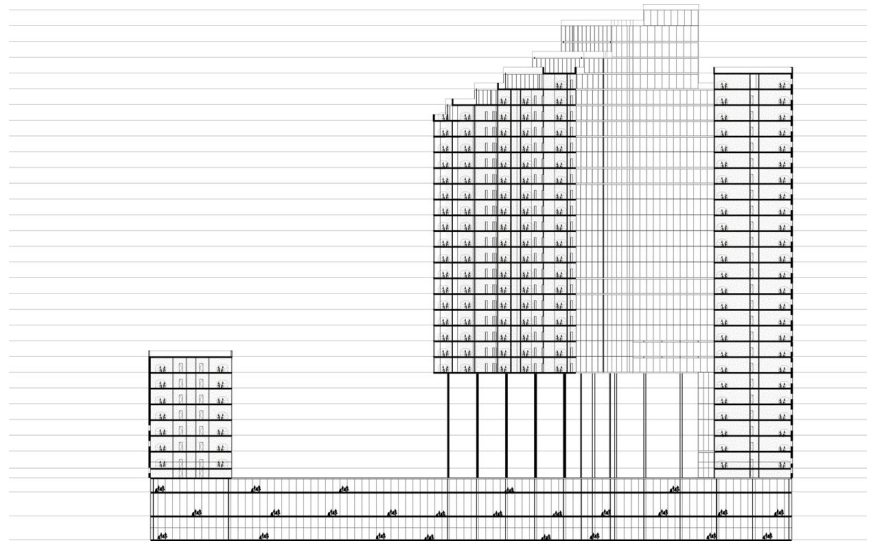
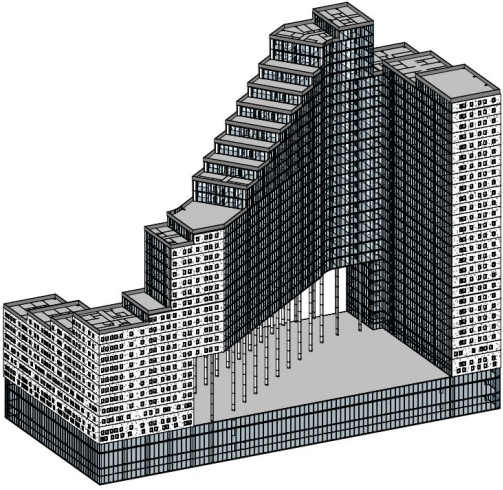

Optimized Response



Optimized Section Response





mersive Image

06 FACADE DETAILING_NEW CURTAIN WALL DESIGN

2022 Spring | A4444-1 Façade Detailing: New Curtain Wall Design | Instructor: Kevin Schorn

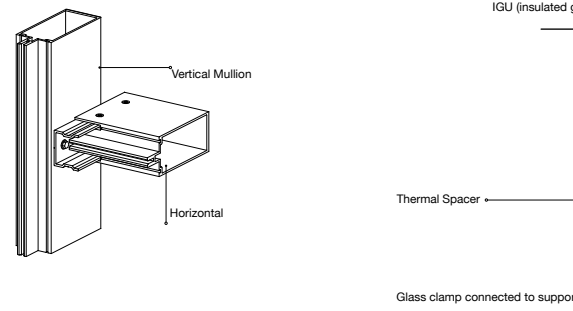

Frame Installation

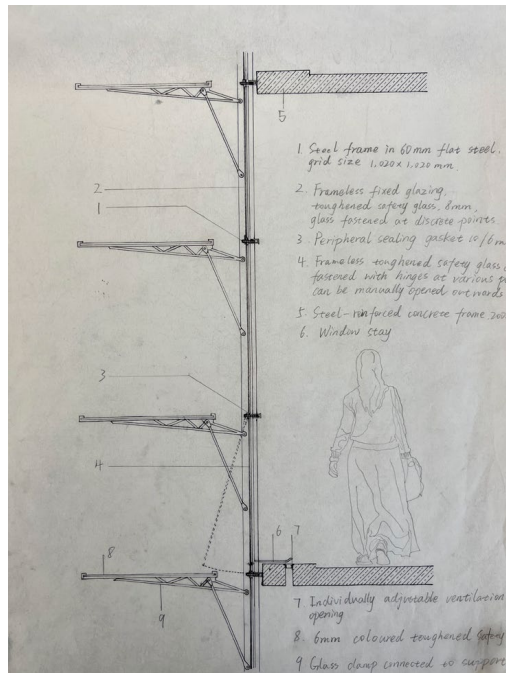

SKETCH

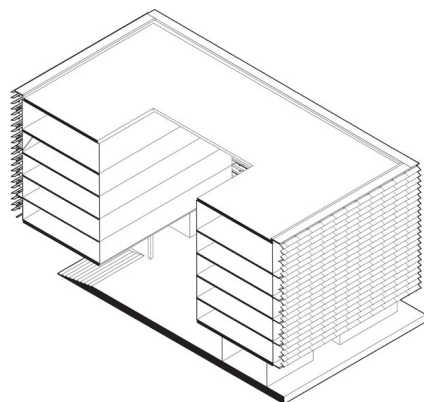

SECTION



ELEVATION

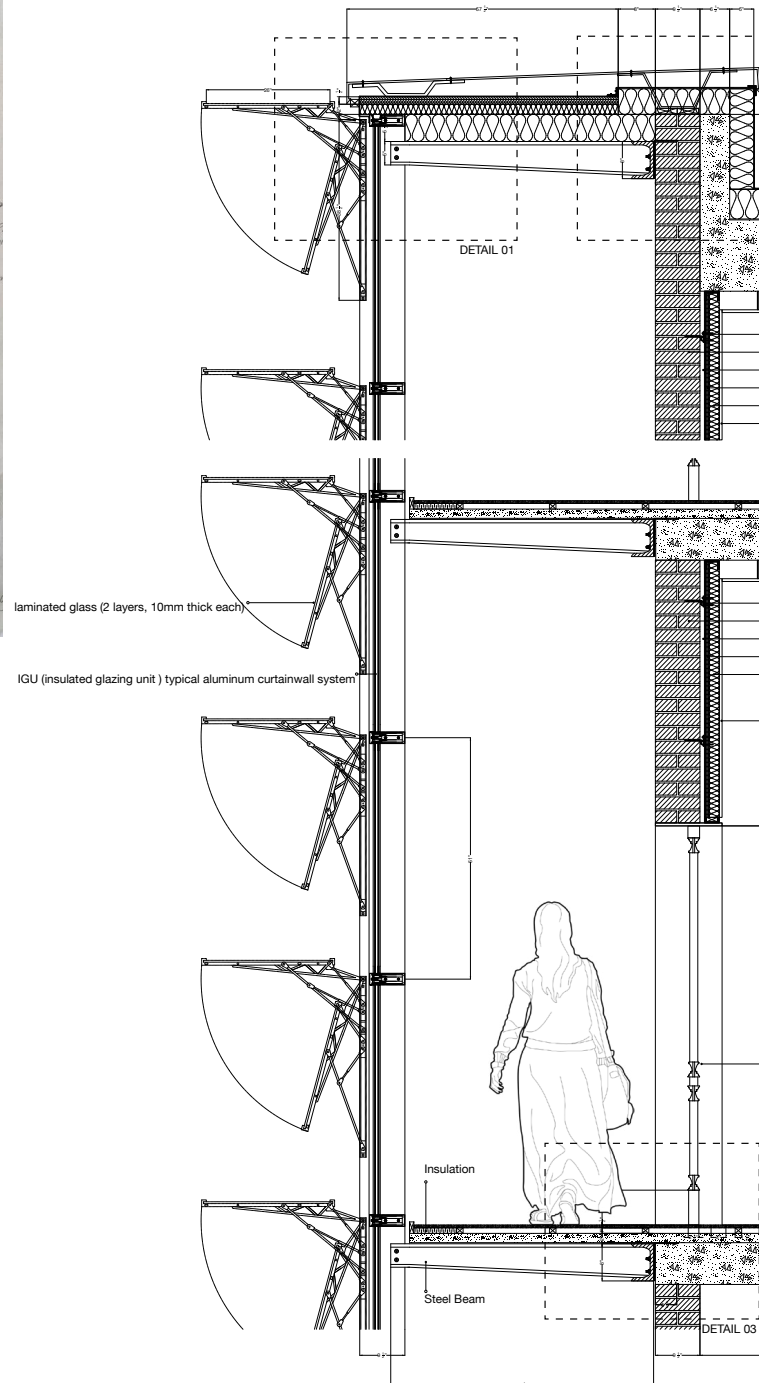

DETAIL 1 = 1'-0" (1:12)

