

# Handling Grapple (GHG)

## FEATURES

- 1 Single cylinder with dual drag links minimizes the number of moving parts and simplifies the hydraulic system
- 2 Streamlined tine, frame and linkage design with easy-to-locate grease fittings simplifies maintenance
- 3 Oversized cylinder design incorporates rod protection, maximum crushing force to densify material, bolt-on gland cap for durability, and easy maintenance
- 4 Large recessed side covers provide easy access to internal components while protecting the cover fasteners
- 5 Common pins, pin keepers and bearings
- 6 Tines close at a very flat angle to assist in compacting material
- 7 Strong rotation system resists back-driving forces when compressing material
- 8 Positive tine stops take the load off the cylinder, extending life

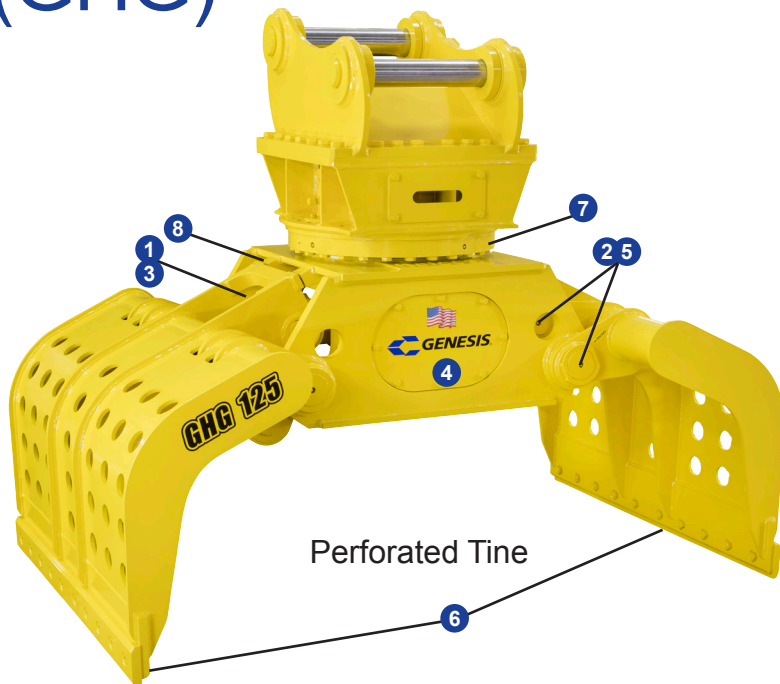

Perforated Tine

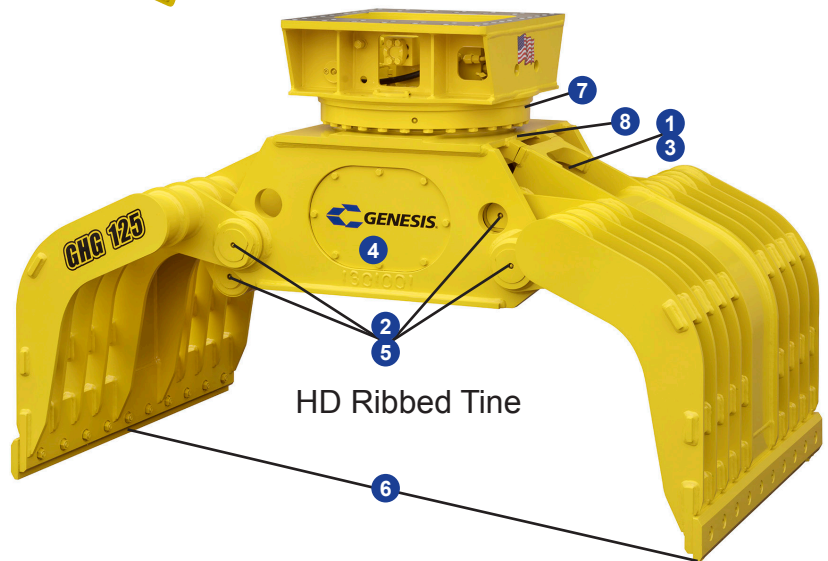

HD Ribbed Tine

Ribbed and Perforated Tine

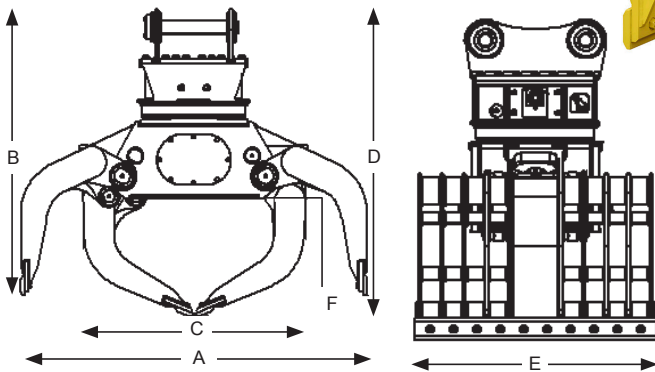

## APPLICATIONS

- Waste Handling and Recycling
- C & D Material Handling and Sorting
- Primary Demolition

DIAGRAM DIMENSION		Weight*		A	B	C	D	E	F	Min. Machine Size
Model	Capacity	(lbs.)		Jaw Open Width	Jaw Open Height	Jaw Closed Width	Jaw Closed Height	Tine Width Footprint	Jaw Closed Depth	
	(yd <sup>3</sup> )	Ribbed	Perforated	(ins.)	(ins.)	(ins.)	(ins.)	(ins.)	(ins.)	(mt)
<b>GHG 75</b>	0.75	3,150	3,200	80	68.5	47	75	37.75	26	15 - 22
<b>GHG 100</b>	1.00	4,300	4,200	87	70.5	56	75	43.5	28	20 - 29
<b>GHG 125</b>	1.25	4,900	4,800	87	70.5	56	75	53	28	25 - 38

\*Weight includes connection bracket.

Genesis Handling Grapples are covered by a 12-month, 1,500-hour (whichever occurs first) warranty.

Genesis reserves the right to continually make product improvements designed to positively enhance product performance.

Patents: [genesisattachments.com/products/patents](http://genesisattachments.com/products/patents)