

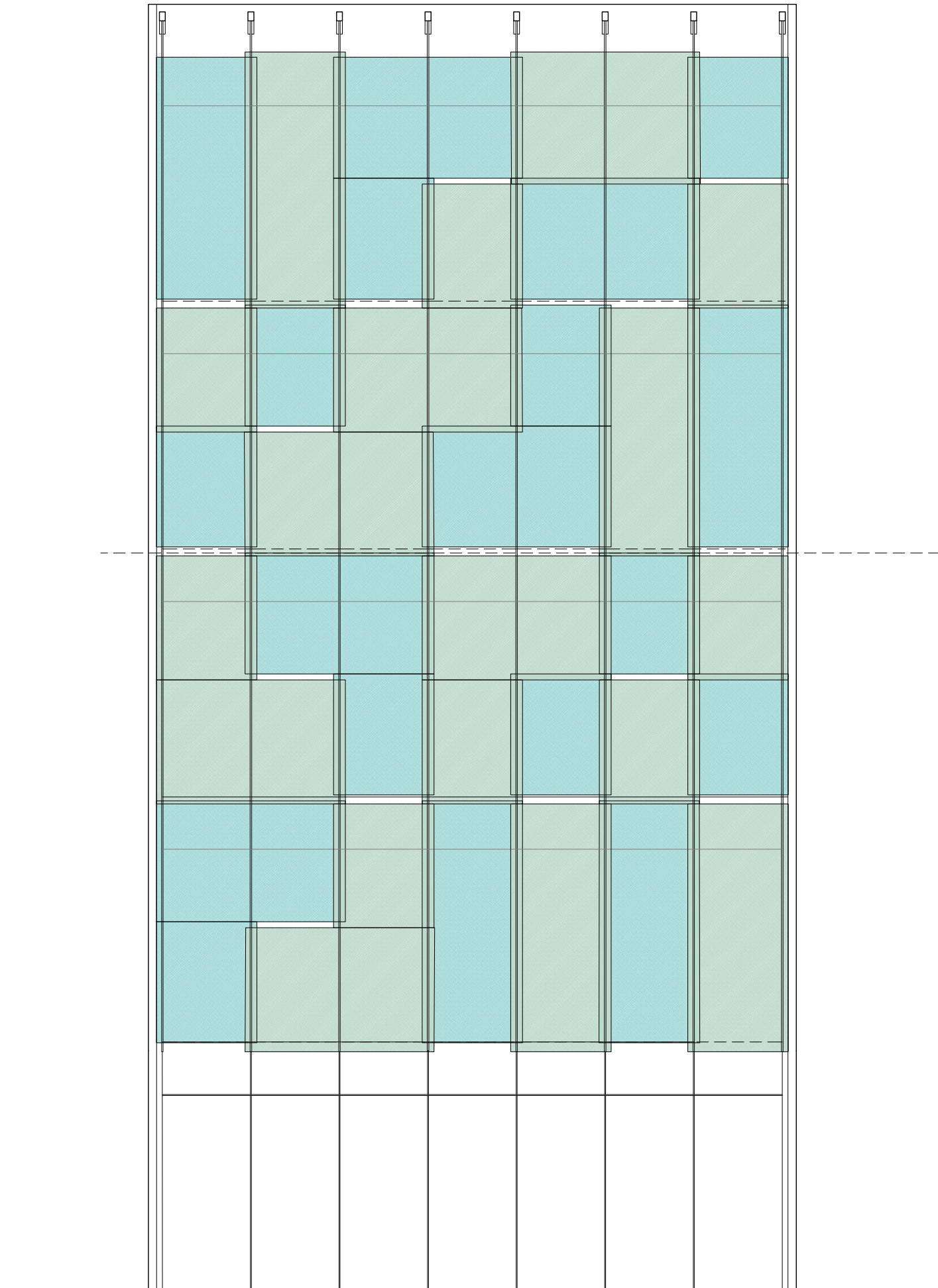

ADVANCED CURTAIN WALL
Helena Pestana
Spring 2020

NATHAN SLATE JOSEPH

History Lesson #1, 2002
Pure color pigment on galvanized steel
36 x 36 x 2"



FULL BUILDING ELEVATION

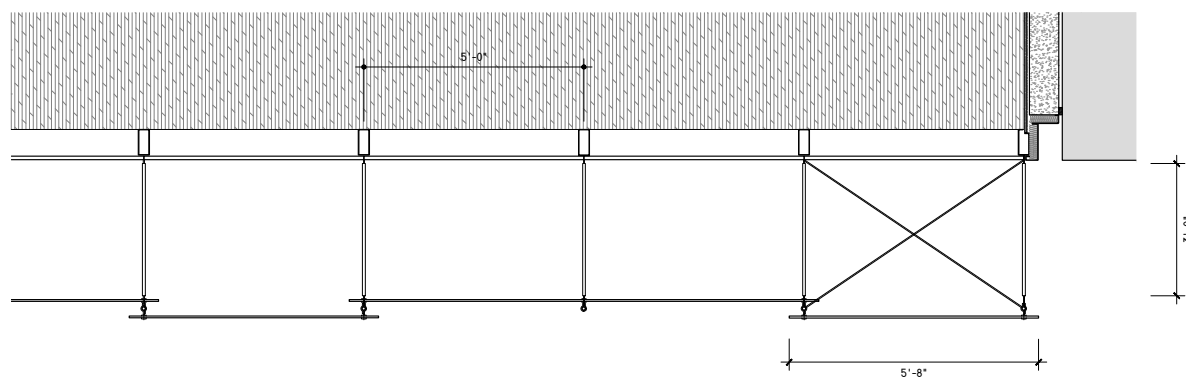
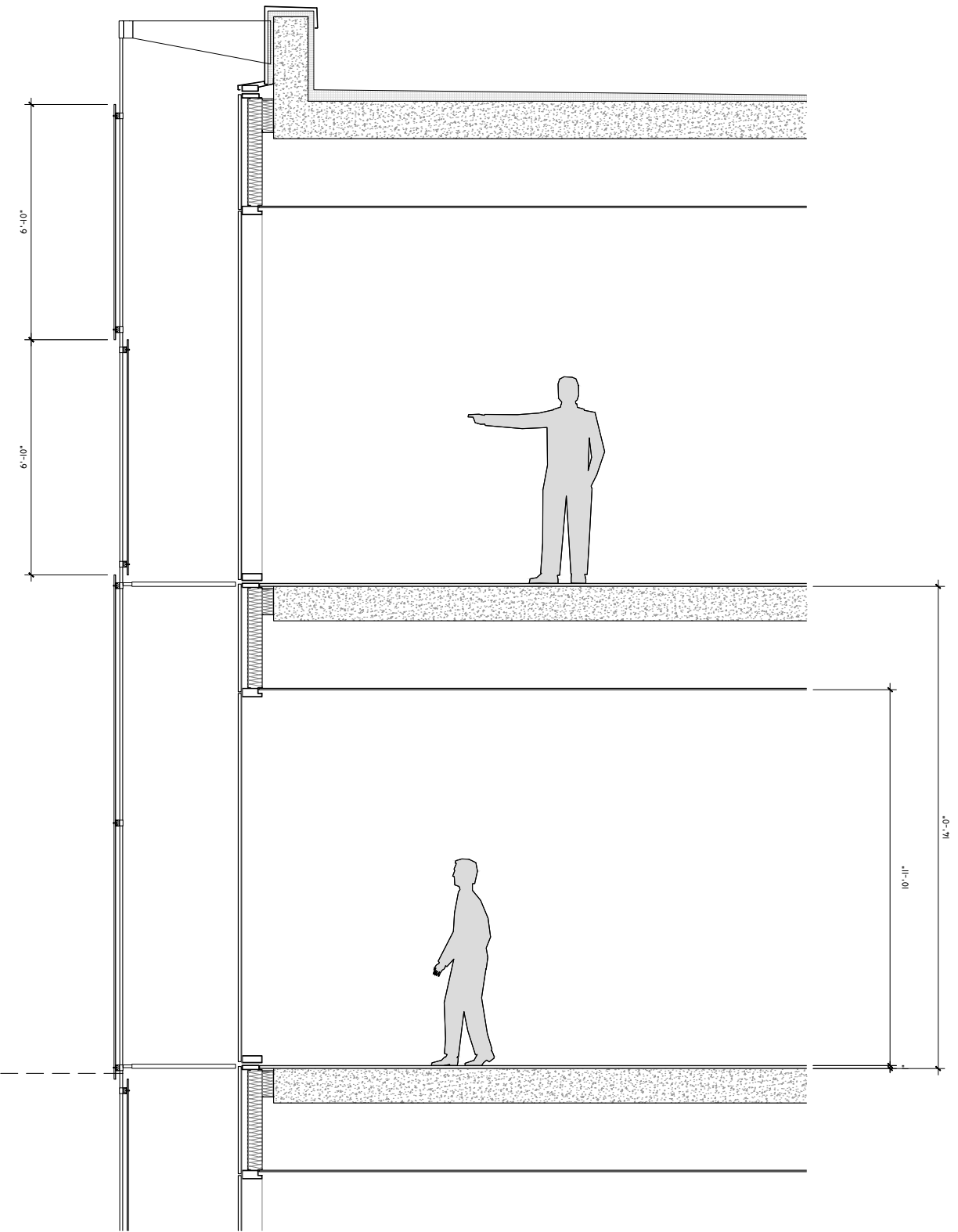
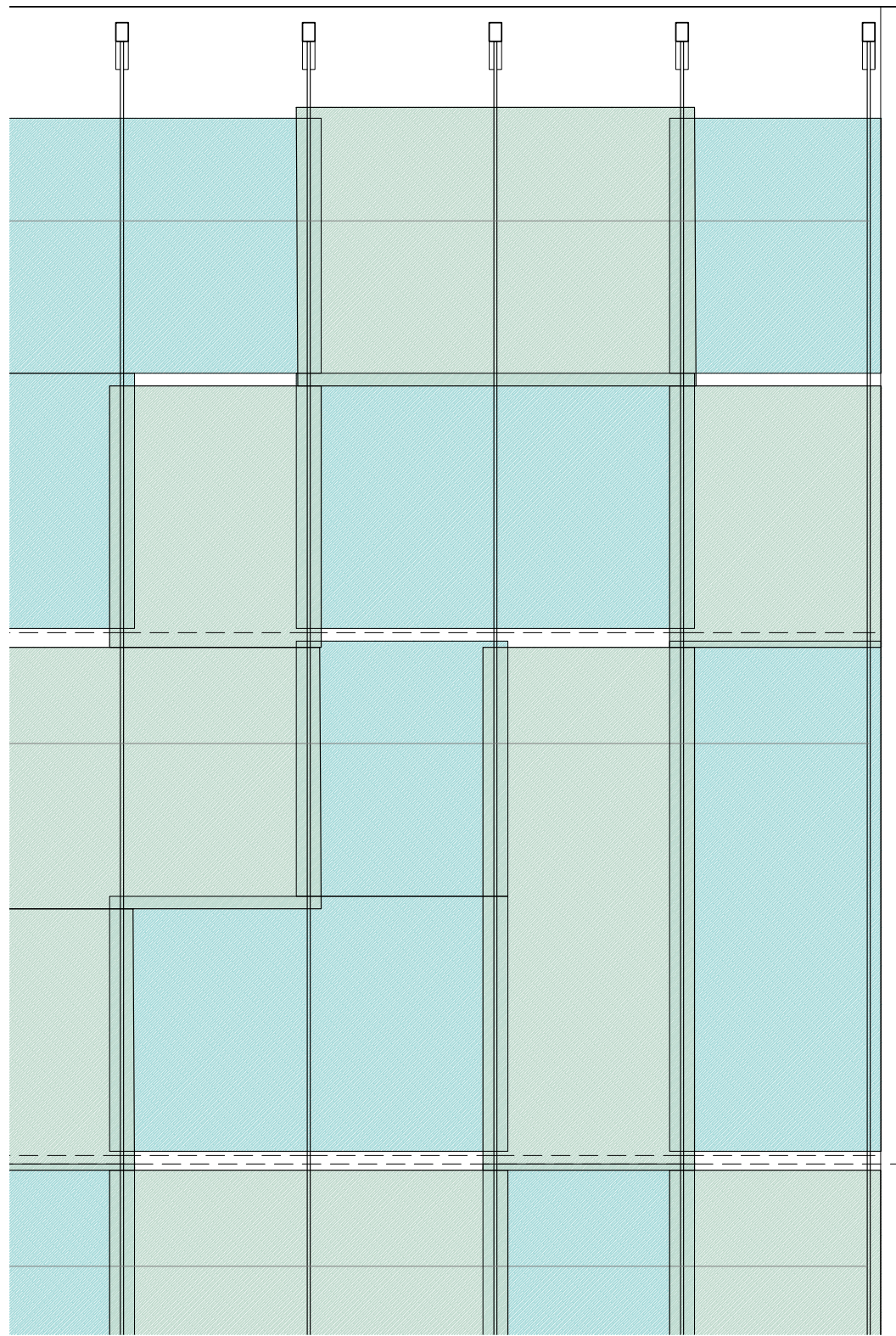

ROADMAP

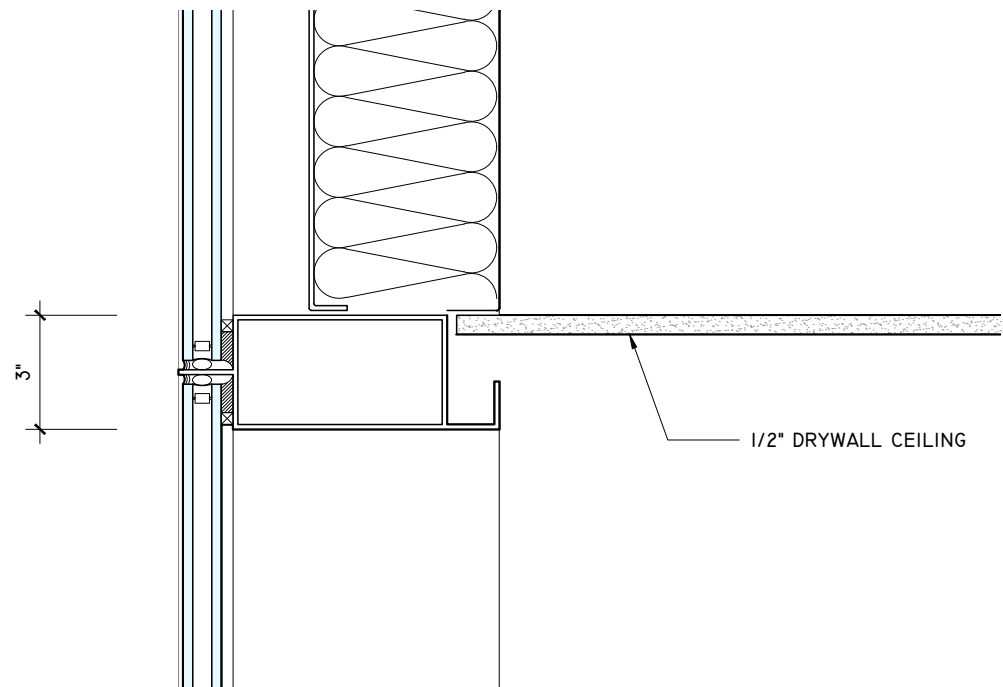
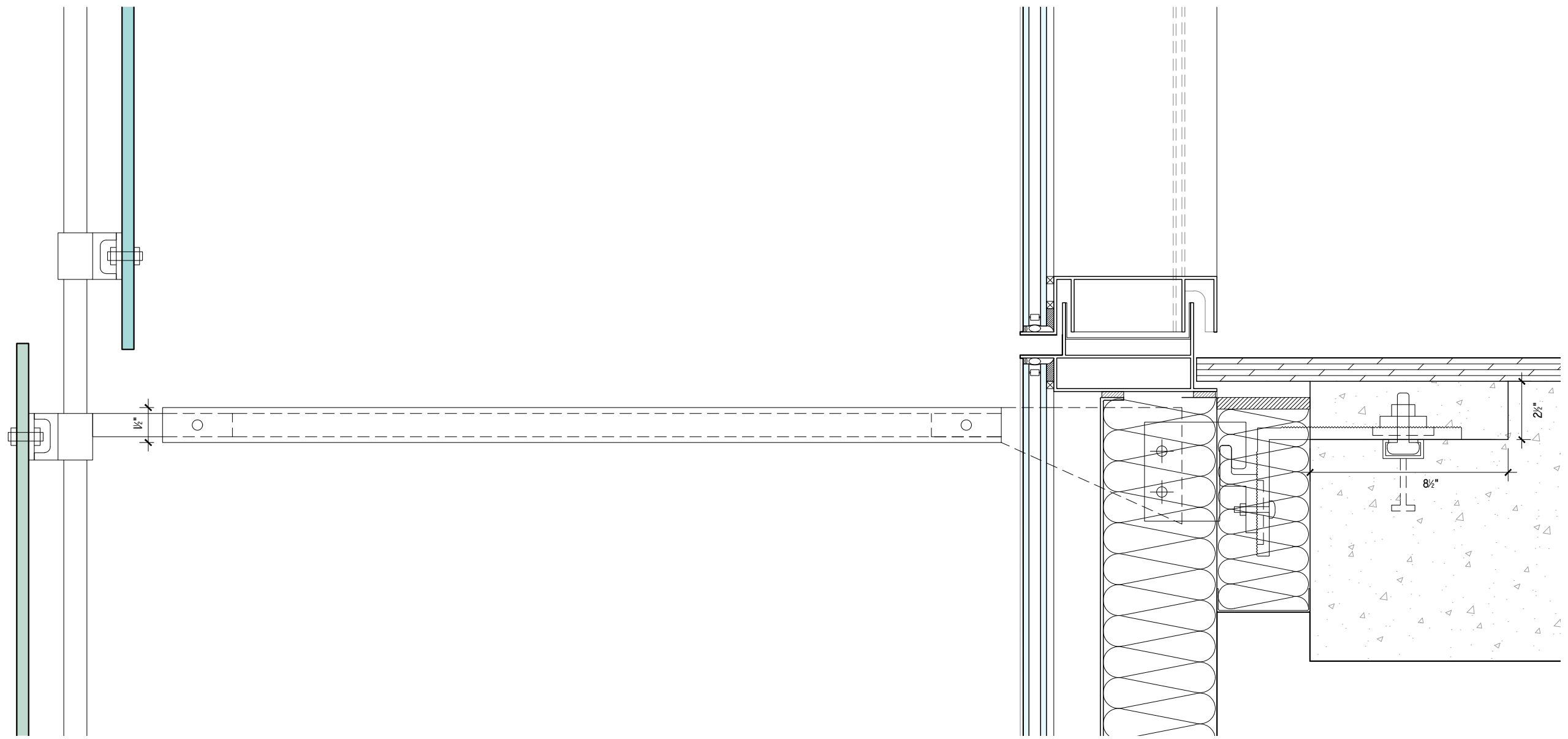

STACK JOINT AND TRANSOM DETAIL

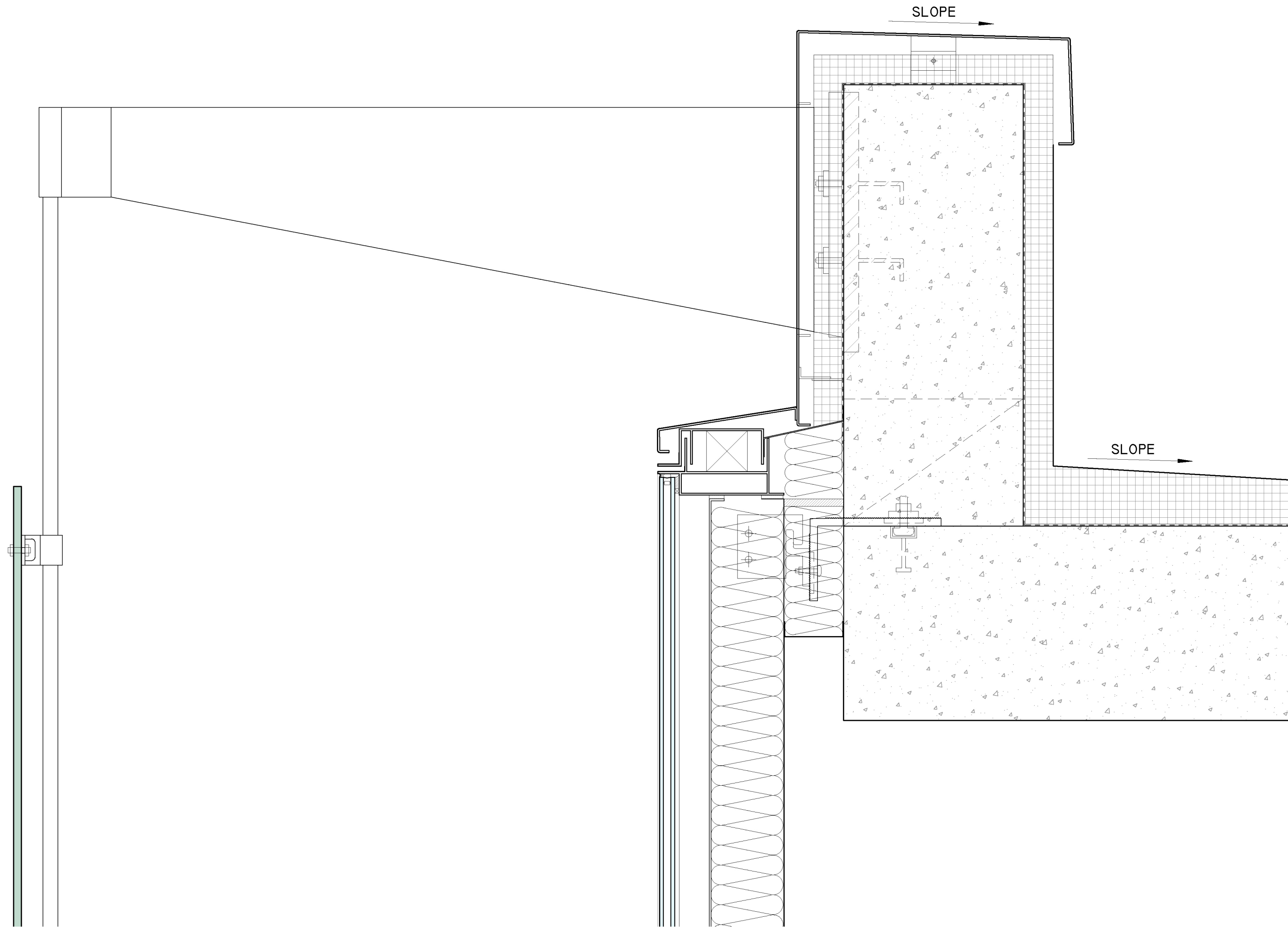

ROOF DETAIL

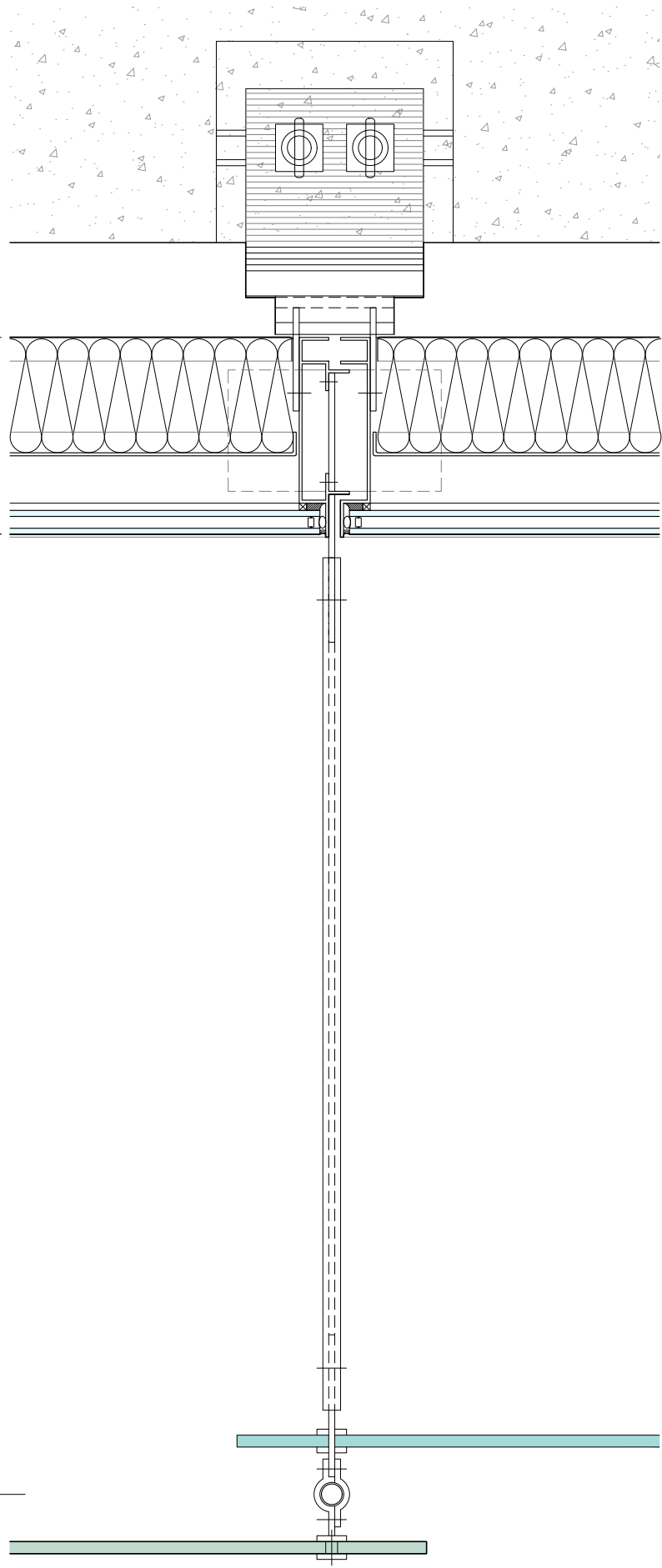

8 3/4"

3'-4 1/2"

MULLION DETAILS

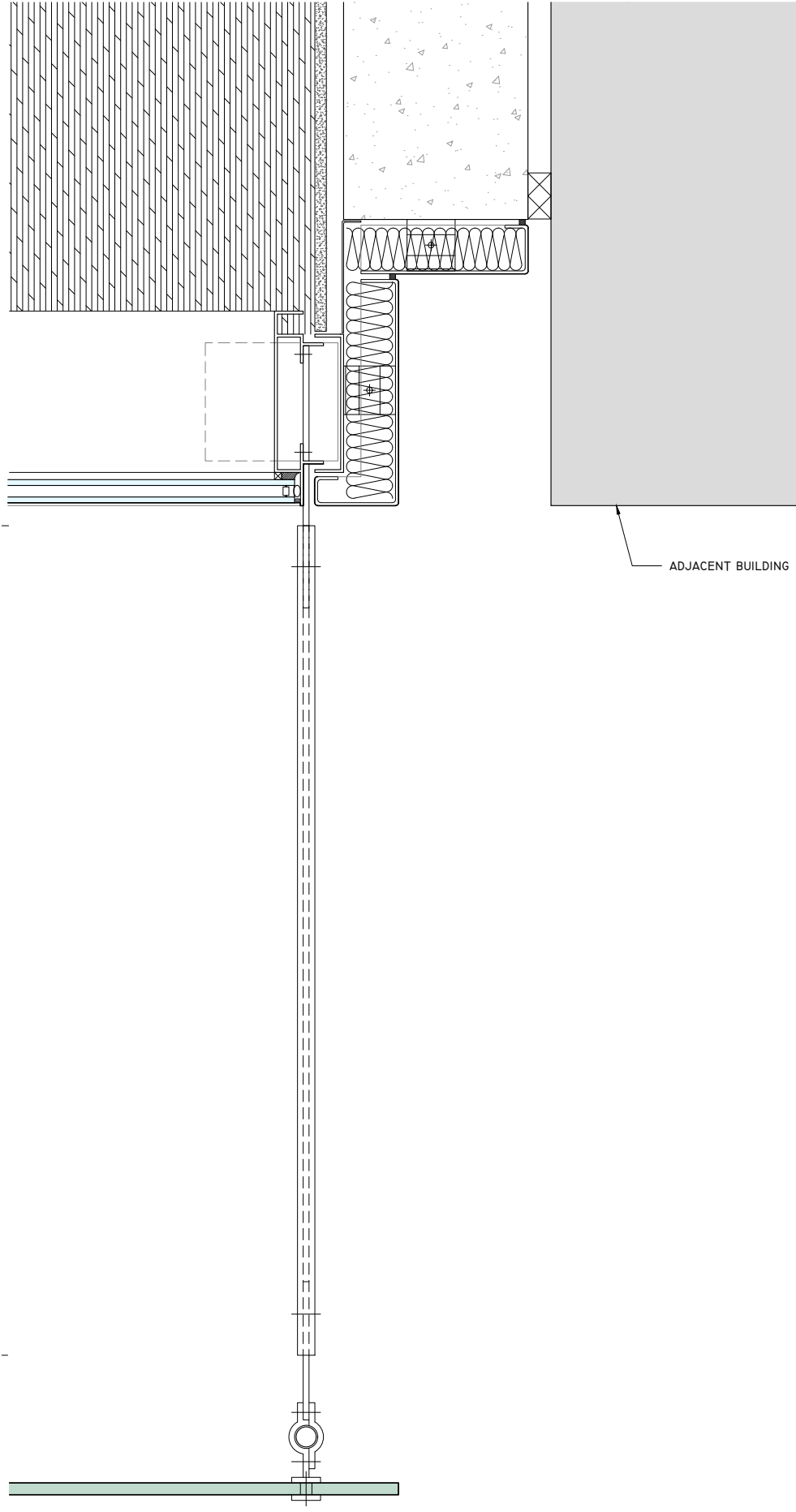
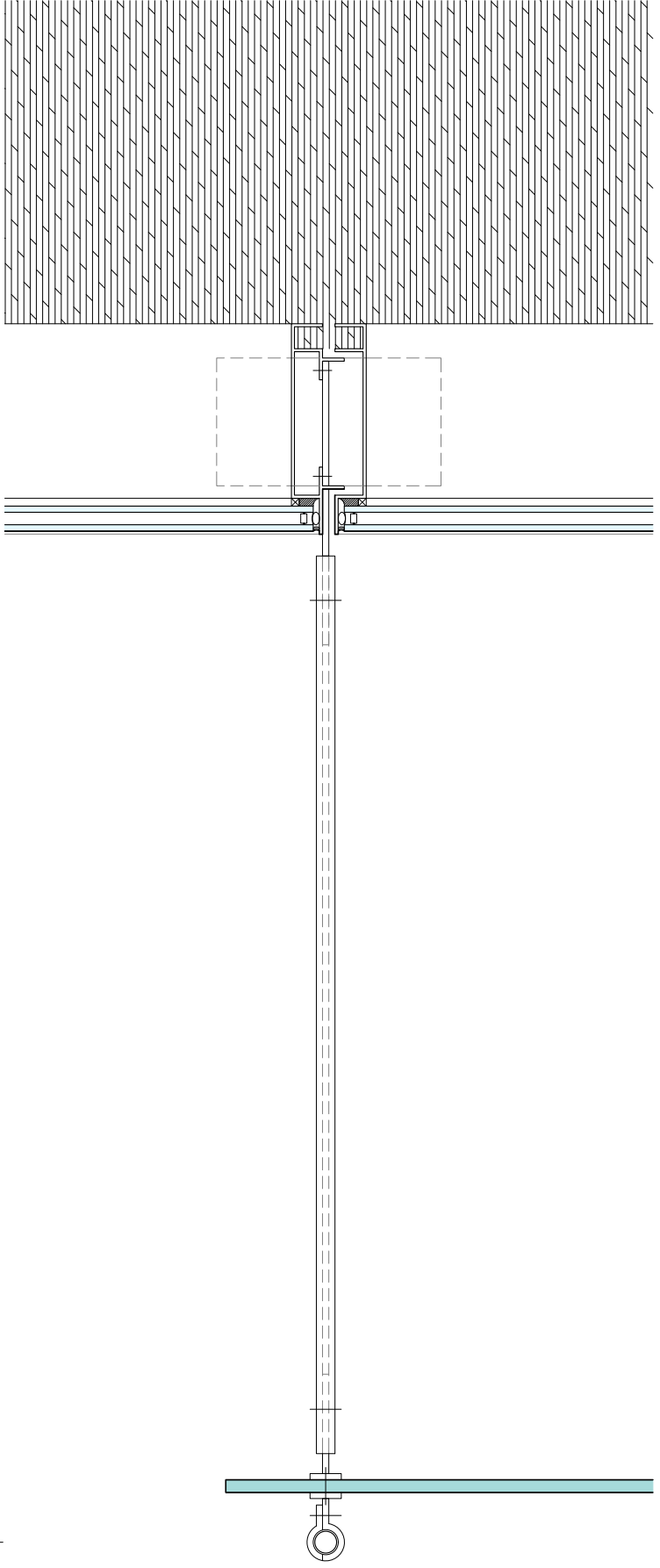

ADJACENT BUILDING

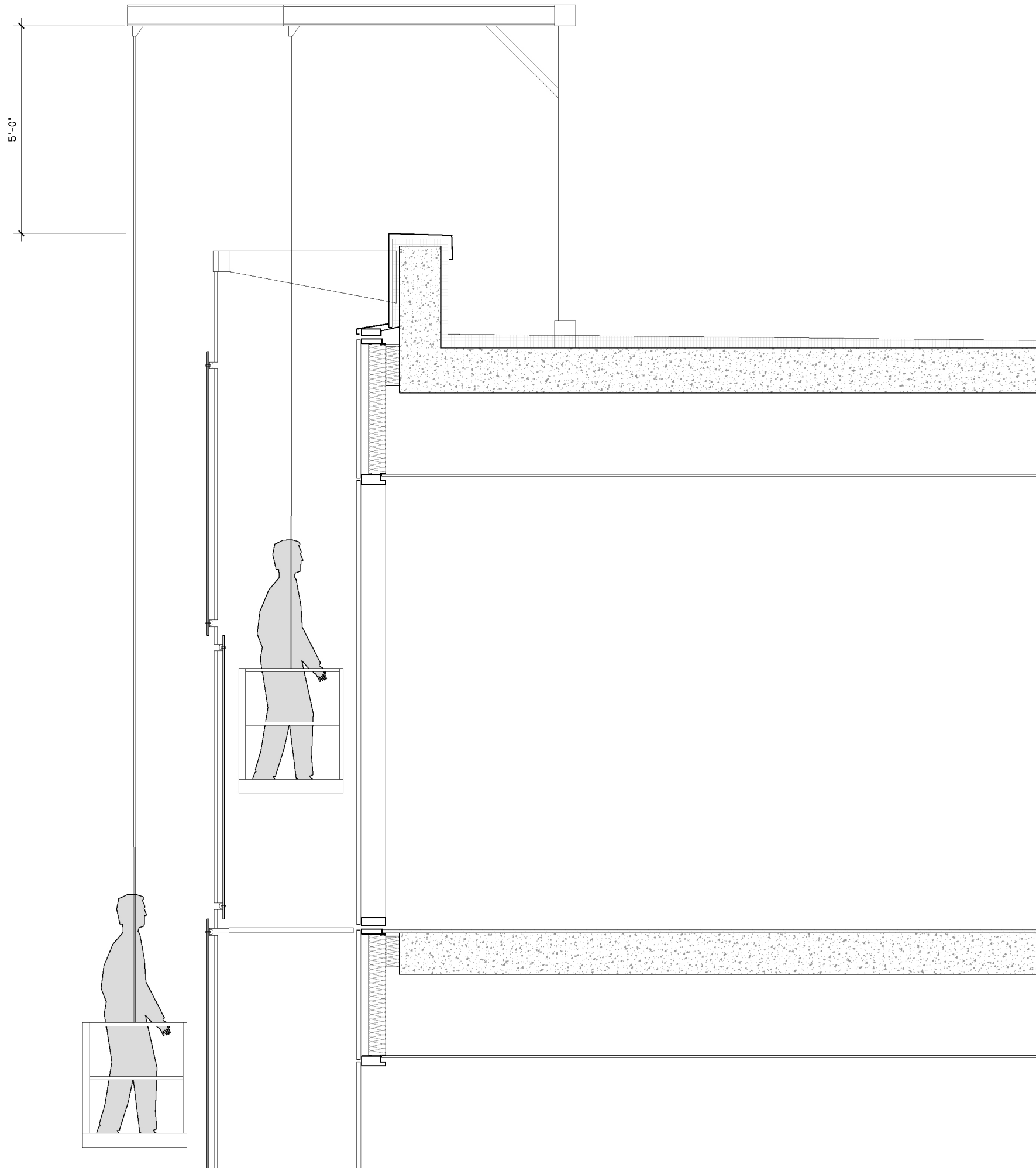

BUILDING SECTION WITH MAINTENANCE STRATEGY

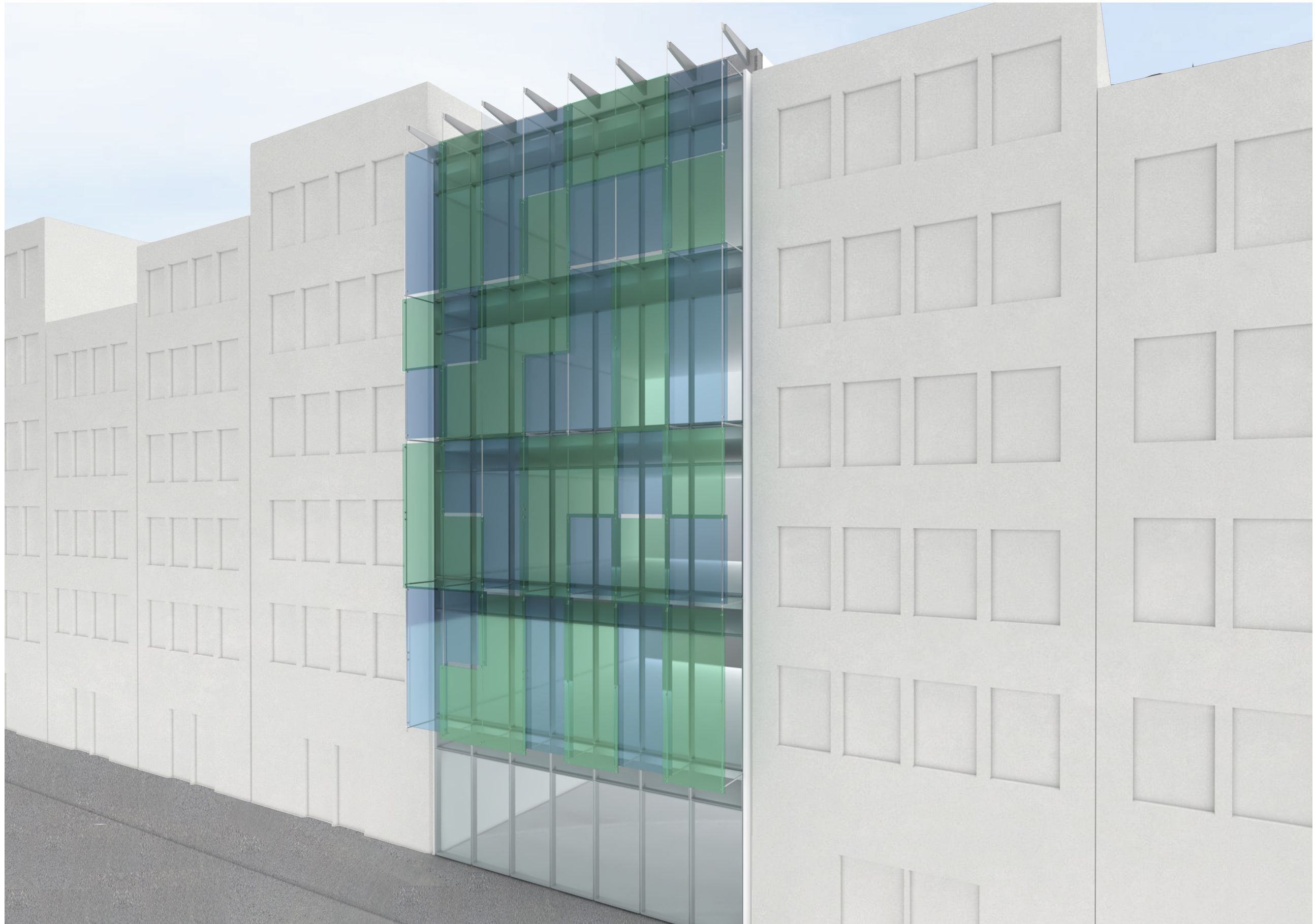

PERSPECTIVE VIEW



FAÇADE DETAIL